

Jan.1.2021 Copyright 2021 HIROSE ELECTRIC CO., LTD. All Rights Reserved.
 In case of consideration for using Automotive equipment / device which demand high reliability, kindly contact our sales window correspondents.

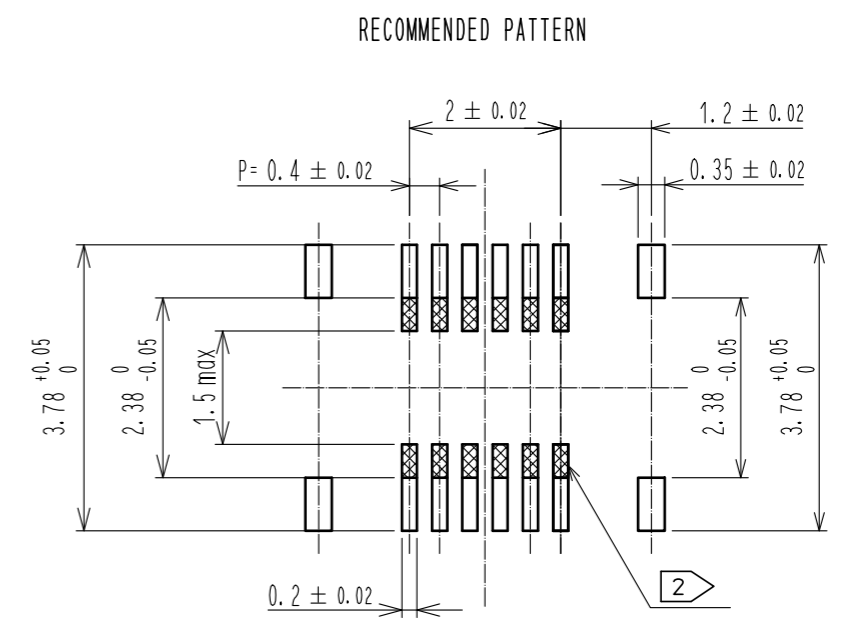

RECOMMENDED METAL MASK THICKNESS: 120 μm
 RECOMMENDED METAL MASK OPENING RATIO: 80% FOR LEAD PAD

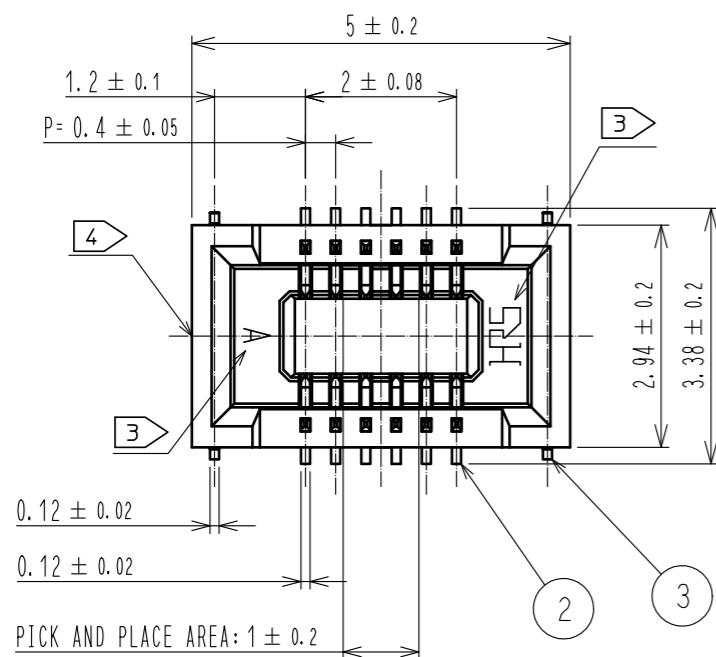
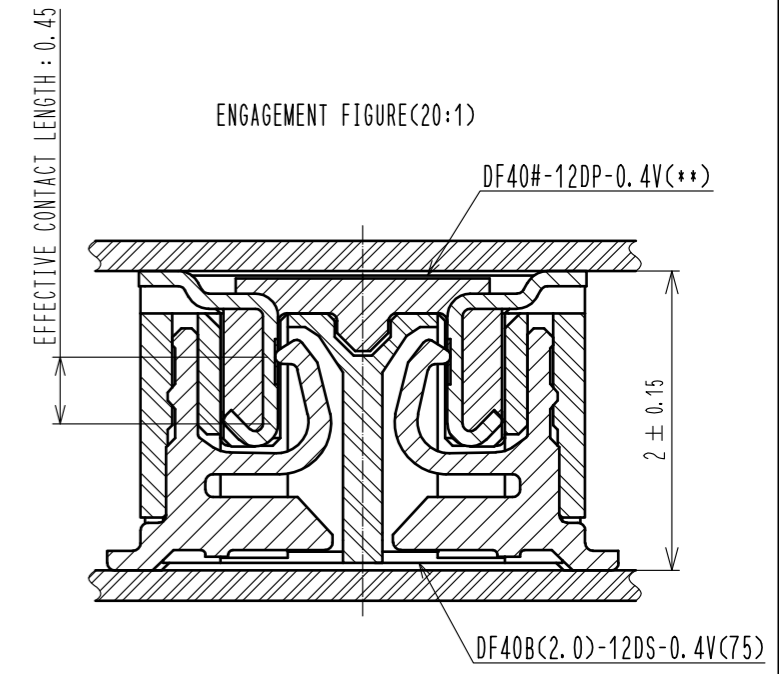
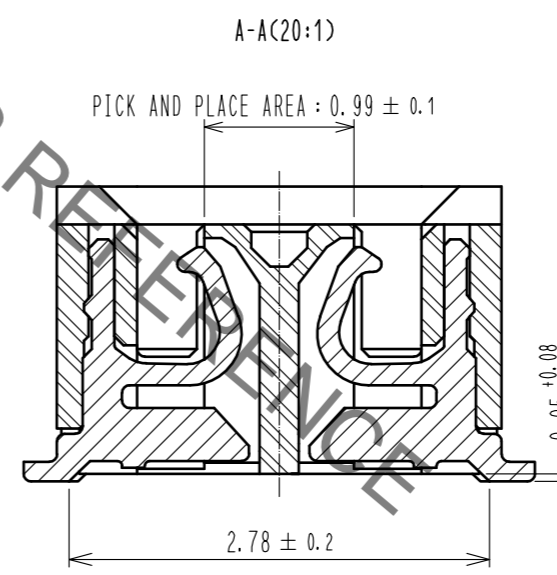
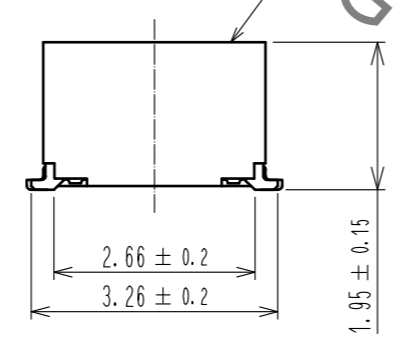
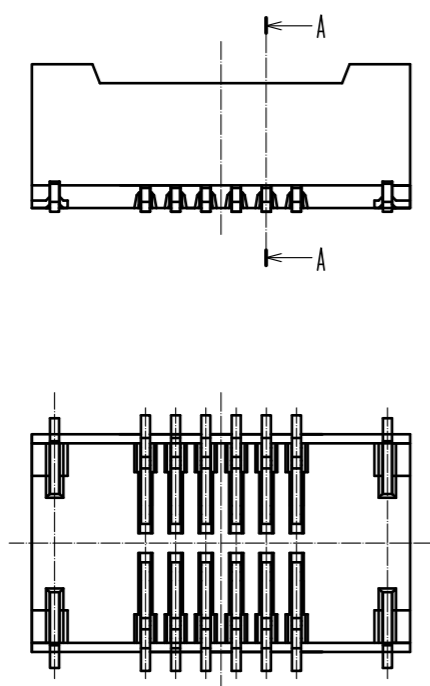

NOTES) 1. ALL LEADS CO-PLANARITY SHALL BE 0.1MAX.
 2. IS NO PATTERN AREA OTHER THAN THE SAME CIRCUIT.
 3. HRS MARK AND CAV NO. IS INDICATED IN APPROX POSITION SHOWN.
 4. GATE POSITIONS IS LOCATED IN APPRIXIMAL AREA.
 A PART OF THE WALL MAY BE NOTCHED FOR SETTING GATE.

2	PHOSPHOR BRONZE	CONTACT AREA : GOLD 0.1 μm MIN SMT LEAD : GOLD 0.05 μm MIN UNDERPLATING : NICKEL 1 μm MIN	7	PS	CLEAR, REINFORCEMENT COLLAR		
1	LCP	BLACK, UL94V-0	6	PS	BLACK, PLASTIC REEL		
			5	POLYESTER	CLEAR, COVER TAPE		
			4	PS	CLEAR, EMBOSSED CARRIER TAPE		
			3	PHOSPHOR BRONZE	GOLD 0.05 μm MIN UNDERPLATING : NICKEL 1 μm MIN		
NO.	MATERIAL	FINISH . REMARKS	NO.	MATERIAL	FINISH . REMARKS		
UNITS	mm	SCALE 10:1	COUNT	DESCRIPTION OF REVISIONS	DESIGNED	CHECKED	DATE
HIROSE ELECTRIC CO., LTD.		APPROVED : WR. FUKUCHI 20200825	DRAWING NO. EDC-332417-75-00				
		CHECED : TS. MIYAZAKI 20200825	PART NO. DF40B(2.0)-12DS-0.4V(75)				
		DESIGNED : RH. KITAGAWA 20200825	CODE NO. CL684-4150-8-75				
		DRAWN : YK. MITSUISHI 20200825					

Jan.1.2021 Copyright 2021 HIROSE ELECTRIC CO., LTD. All Rights Reserved.
 In case of consideration for using Automotive equipment / device which demand high reliability, kindly contact our sales window correspondents.

EMBOSED CARRIER TAPE DIMENSIONS (5:1)

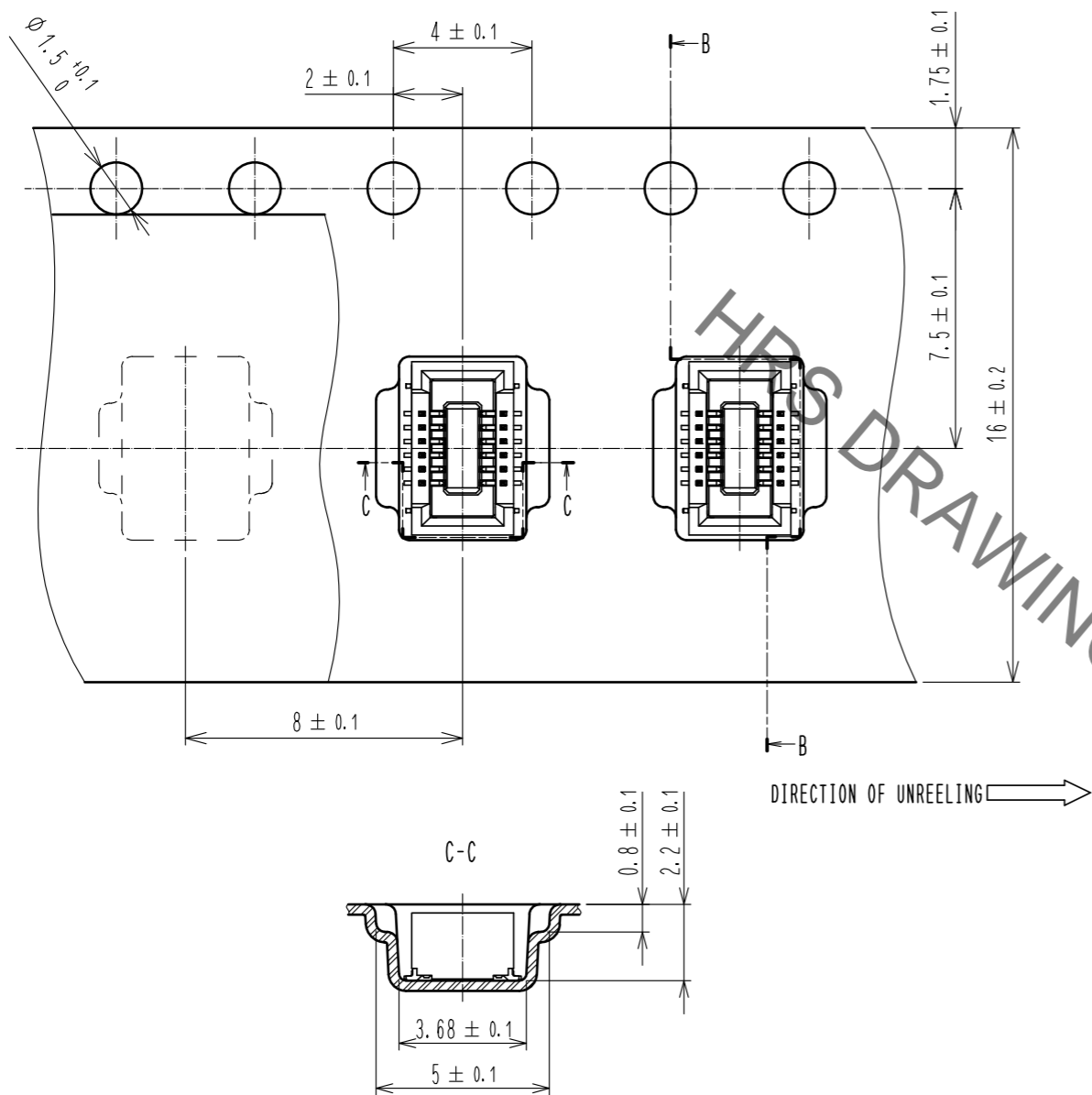

STYLE AND DIMENSION OF REEL (FREE SIZE)

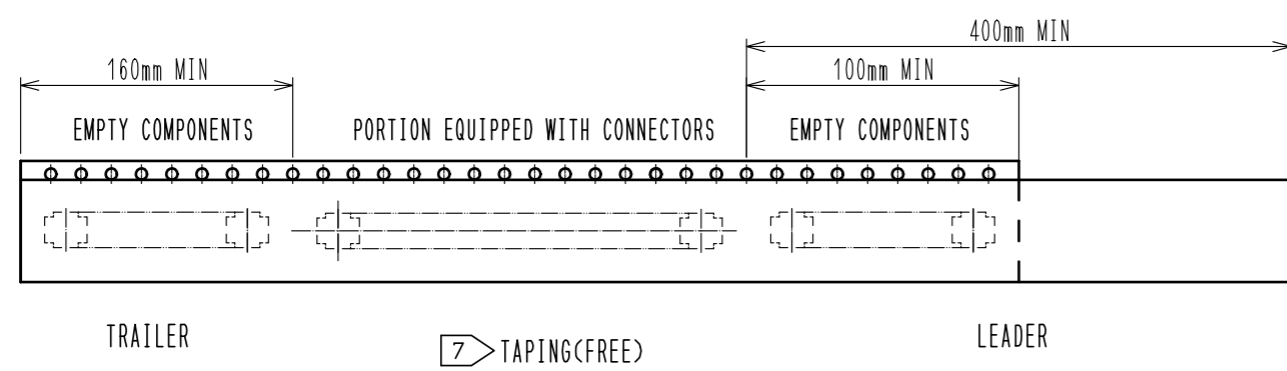
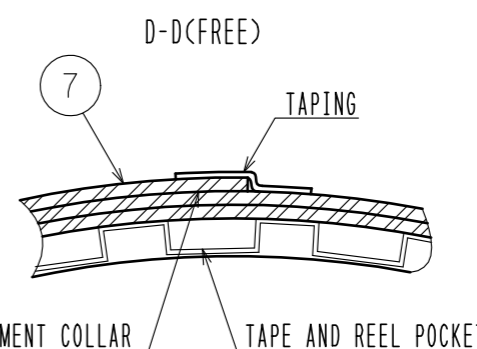
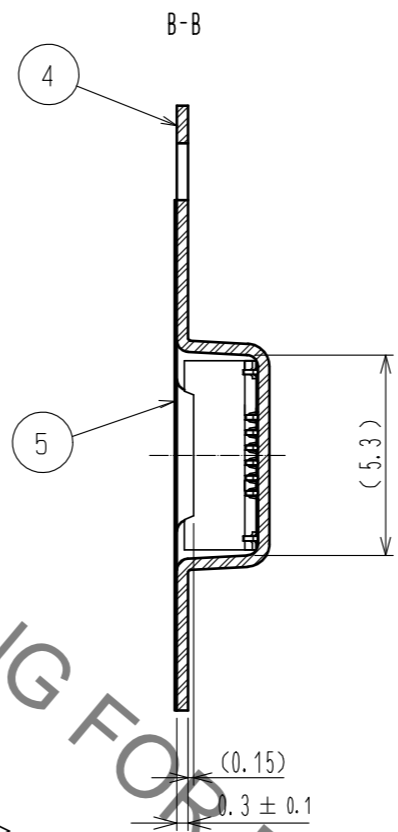
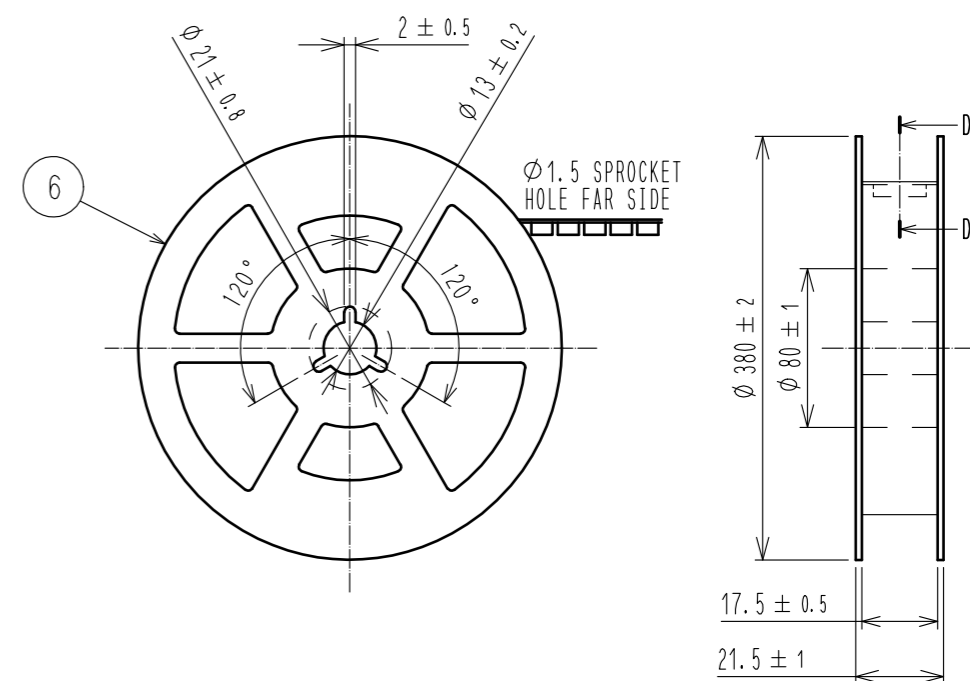

- NOTES) 5. PER REEL 4000 CONNECTORS.
 6. THE DIMENSIONS IN PARENTHESES ARE FOR REFERENCE.
 7. REFER TO JIS C 0806, IEC 60286-3. (PACKAGING OF COMPONENTS FOR AUTOMATIC HANDLING)
 8. AFTER PACKAGING, ROLL 2 METERS OF THE REINFORCEMENT COLLAR TO OUTER CIRCUMFERENCE OF TAPE AND REEL POCKET. AND TAPE DOWN AT THE END THE COLLAR.

HRS	DRAWING NO.	EDC-332417-75-00
	PART NO.	DF40B(2.0)-12DS-0.4V(75)
	CODE NO.	CL684-4150-8-75
		2/2