

Nov.1.2019 Copyright 2019 HIROSE ELECTRIC CO., LTD. All Rights Reserved.  
In case of consideration for using Automotive equipment / device which demand high reliability, kindly contact our sales window correspondents.

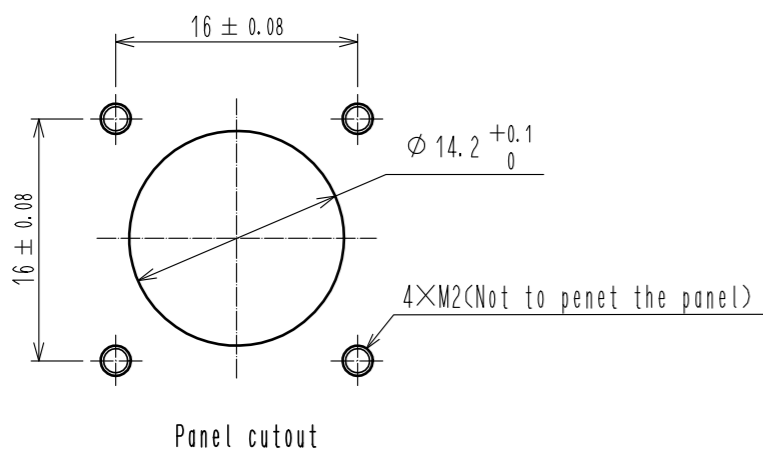
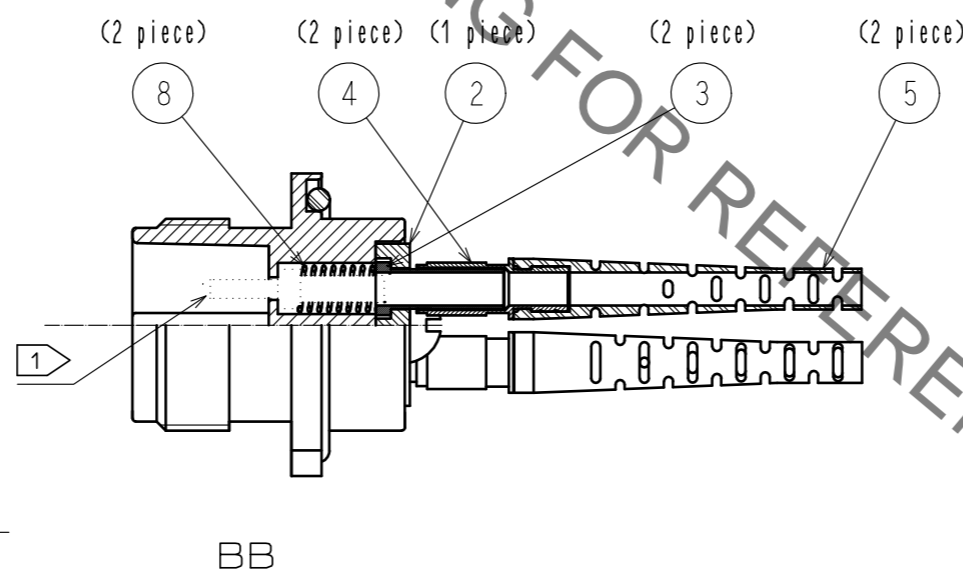
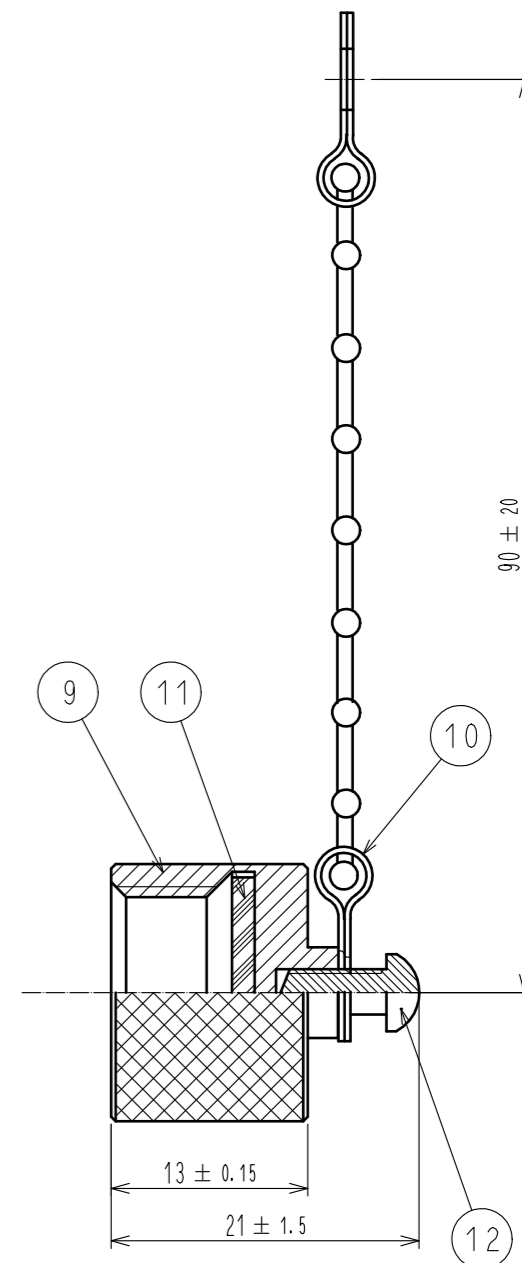
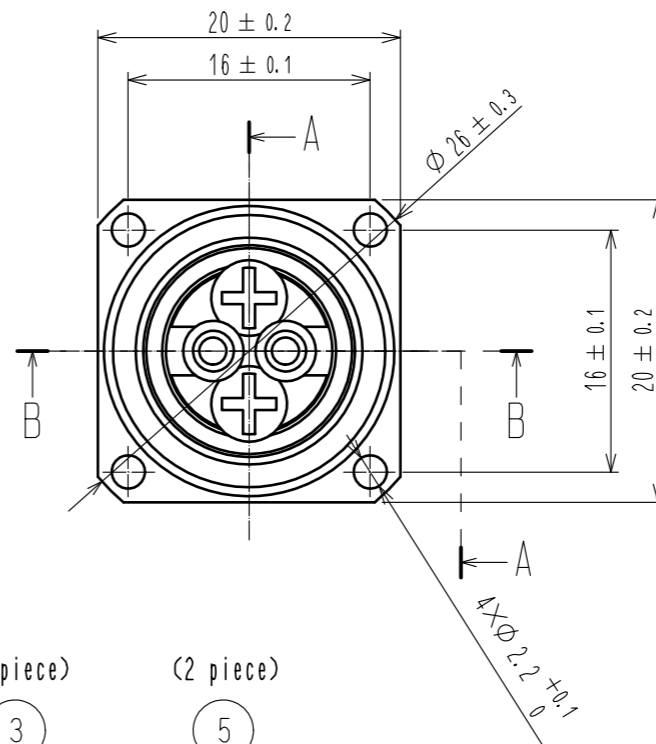
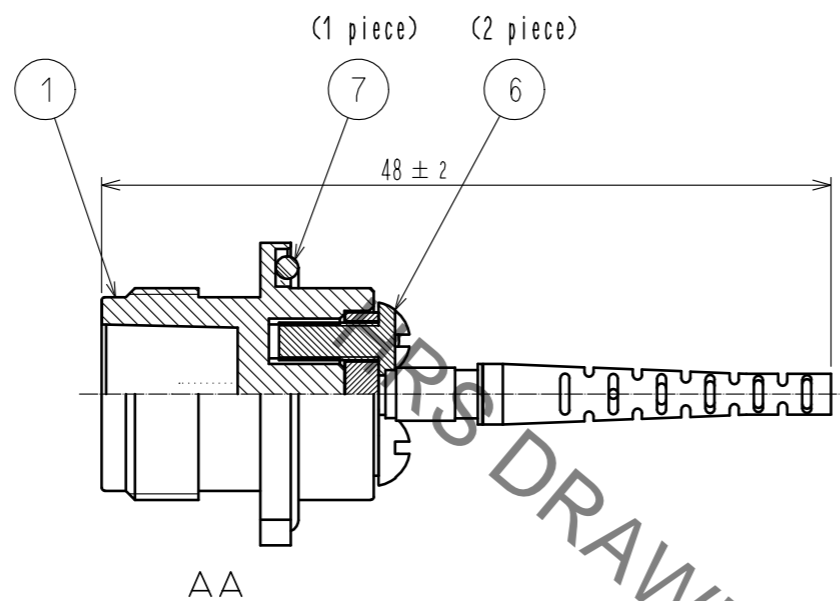
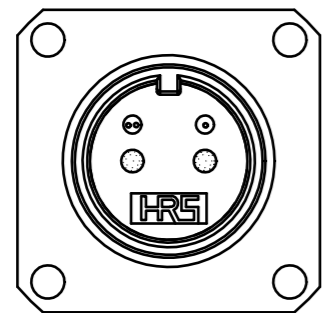

Note 1 Ferrules are not included in this product. Please use an optional MU ferrule.  
2. The assembled cap is inserted into this product and delivered.

6	Stainless steel		12	Stainless steel	Nyrock
5	TEPP	Color: Mauve	11	SIR	Color: Transparent
4	Brass	Nickel plating	10	Stainless steel	
3	Brass	Nickel plating	9	Aluminum alloy	Anodic oxide coating(Black)
2	Brass	Nickel plating	8	Piano wire	Zinc plating
1	Zinc die casting	Chrome plating (Black)	7	EPR	Color: Black
NO.	MATERIAL	FINISH . REMARKS	NO.	MATERIAL	FINISH . REMARKS
UNITS		SCALE	COUNT	DESCRIPTION OF REVISIONS	
mm		2 : 1		DESIGNED	CHECKED
<b>HRS</b> HIROSE ELECTRIC CO., LTD.		APPROVED : MT. SHIBUTANI	18.03.30	DRAWING NO. EDC-176272-33-00	
		CHECKED : MT. SHIBUTANI	18.03.30	PART NO. MF10S-WDRFC01-0200(33)	
		DESIGNED : SI. MATSUMOTO	18.03.30	CODE NO. CL709-0526-1-33	
		DRAWN : SR. TOYOKAWA	18.03.30		