

Dec.1.2019 Copyright 2019 HIROSE ELECTRIC CO., LTD. All Rights Reserved.  
In case of consideration for using Automotive equipment / device which demand high reliability, kindly contact our sales window correspondents.

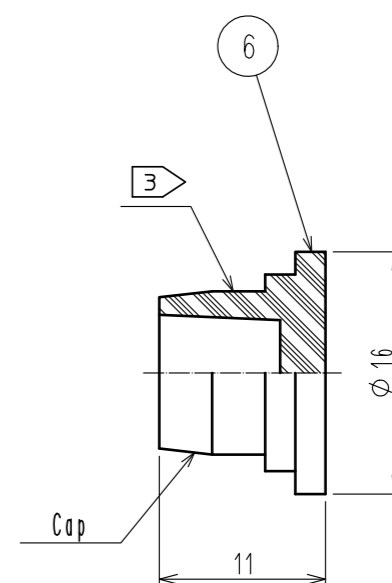

NOTE 1 This dimension shows after assembly.  
2 This product is not attached with a ferrule.  
3 The cap is inserted into this product and delivered.

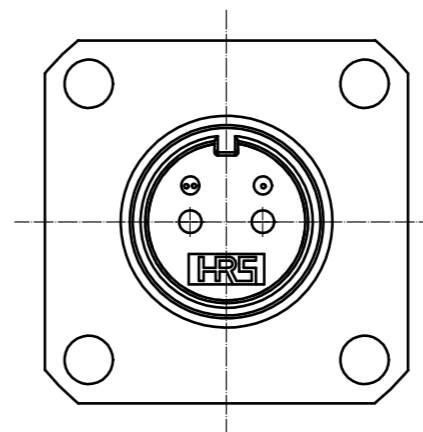
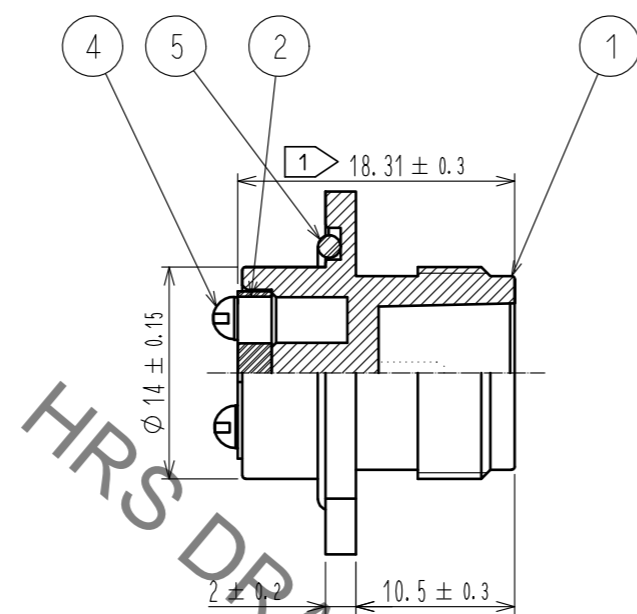
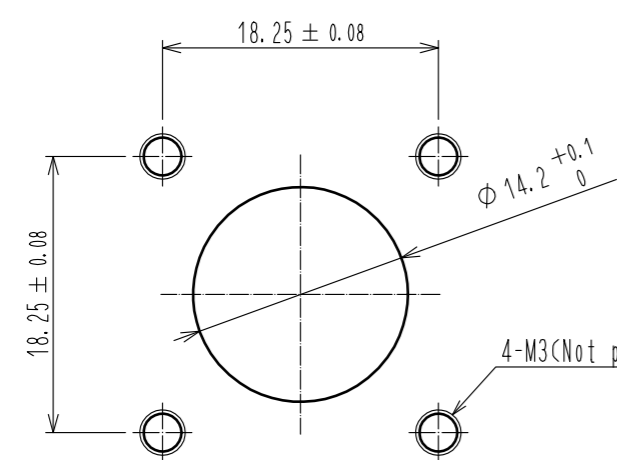
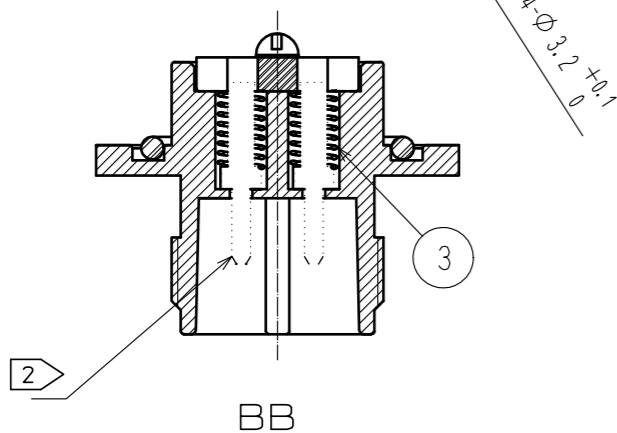
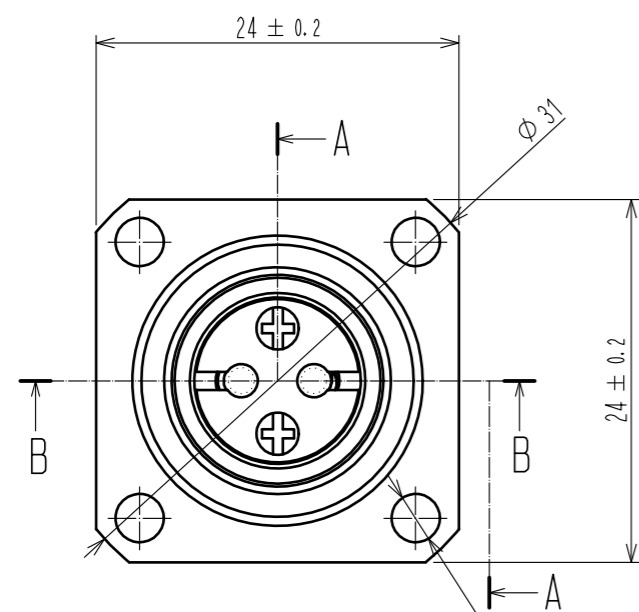
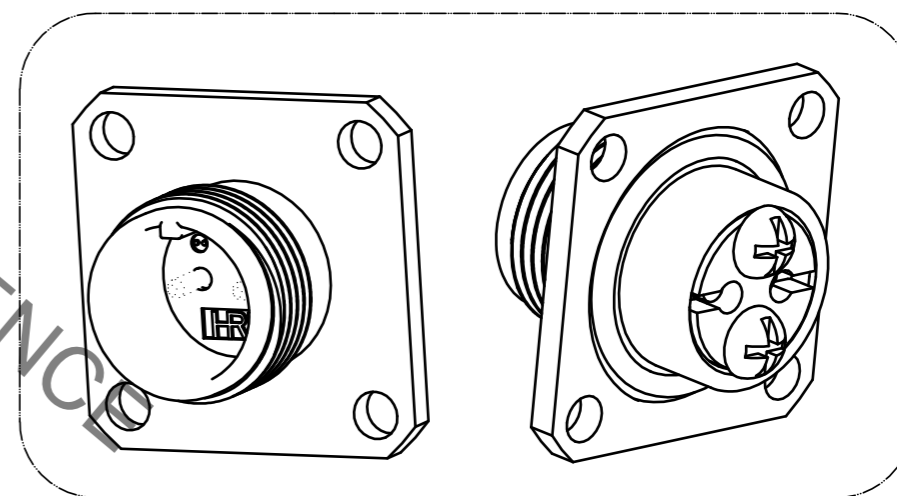

△ Depend on system

NO.	MATERIAL	FINISH .	REMARKS	NO.	MATERIAL	FINISH .	REMARKS
3	Piano wire	Zinc plating		6	SIR	Black	
2	PBT	Black		5	EPDM	Black	
1	Zinc die casting	Nickel plating		4	Stainless steel		

UNITS	SCALE	COUNT	DESCRIPTION OF REVISIONS	DESIGNED	CHECKED	DATE
mm	2 : 1	1	DIS-K-00001425	TY. SATO	FS. YOSHIDA	18.03.26

APPROVED	CHECKED	DESIGNED	DRAWN	DRAWING NO.	PART NO.	CODE NO.
MT. SHIBUTANI	FS. YOSHIDA	SI. MATSUMOTO	SR. TOYOKAWA	EDC-176610-31-00	MF10S-WDRFNG01-0200(31)	CL709-0549-7-31