

Sep.1.2020 Copyright 2020 HIROSE ELECTRIC CO., LTD. All Rights Reserved.
In case of consideration for using Automotive equipment / device which demand high reliability, kindly contact our sales window correspondents.

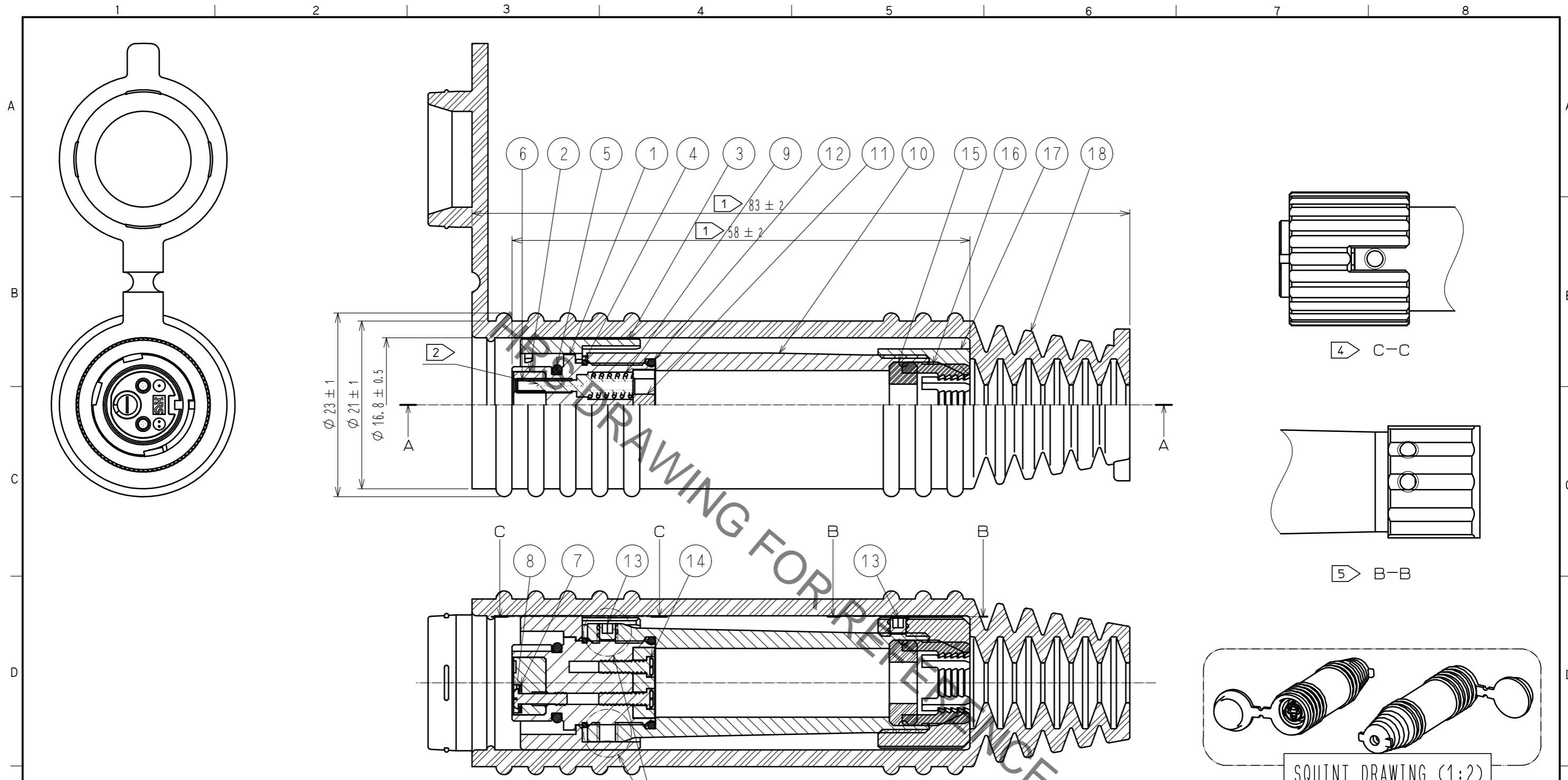

- NOTE
- 1 These dimensions indicate the condition after cable assembly.
 - 2 Ferrules are not included in this product. MU ferrules are separately available.
 3. For connector mating, slide back rubber hood of part No. 18 until whole sleeve of part No. 3 is appeared. After mating, slide the rubber hood back until it touches to the receptacle.
 4. Housing of part No. 10 has two holes for fixing with sleeve of part No. 1 by hexagon socket screw of part No. 13. Tighten the screw at either hole that is visible from a slit on the sleeve as shown in cross section C-C.
 5. Tightening ring of part No. 17 has two holes for fixing hexagon socket screw of part No. 13. Tighten the screw at visible either hole, or either hole if both holes are visible.
 6. For cleaning of the ferrule end, loosen the screw of part No. 8 and pick up the pre-assembled P shell B of part No. 2 by pulling the screw of part No. 8. Then, remove the split sleeves by using separately available sleeve-remover and clean the ferrules.

9	PIANO WIRE	_____	18	SYNTHETIC RUBBER	_____
8	STAINLESS STEEL	_____	17	ZINC DIE CASTING	NICKEL PLATING
7	STAINLESS STEEL	_____	16	SYNTHETIC RESIN	_____
6	ZIRCONIA	_____	15	SYNTHETIC RUBBER	_____
5	SYNTHETIC RUBBER	_____	14	STAINLESS STEEL	_____
4	STAINLESS STEEL	_____	13	STAINLESS STEEL	_____
3	ZINC DIE CASTING	NICKEL PLATING	12	SYNTHETIC RUBBER	_____
2	ZINC DIE CASTING	NICKEL PLATING	11	ZINC DIE CASTING	NICKEL PLATING
1	ZINC DIE CASTING	NICKEL PLATING	10	ZINC DIE CASTING	NICKEL PLATING
NO.	MATERIAL	FINISH . REMARKS	NO.	MATERIAL	FINISH . REMARKS

UNITS mm		SCALE 2 : 1	COUNT 	DESCRIPTION OF REVISIONS	DESIGNED	CHECKED	DATE
HRS HIROSE ELECTRIC CO., LTD.		APPROVED : MT. SHIBUTANI	18.02.02	DRAWING NO.	EDC-176711-31-00		
		CHECKED : FS. YOSHIDA	18.02.02	PART NO.	MF10B-WP6. 5C01-0200(31)		
		DESIGNED : TY. SATO	18.02.02	CODE NO.	CL709-1004-1-31		
		DRAWN : MK. INOUE	18.02.02				