

Sep.1.2020 Copyright 2020 HIROSE ELECTRIC CO., LTD. All Rights Reserved.
In case of consideration for using Automotive equipment / device which demand high reliability, kindly contact our sales window correspondents.

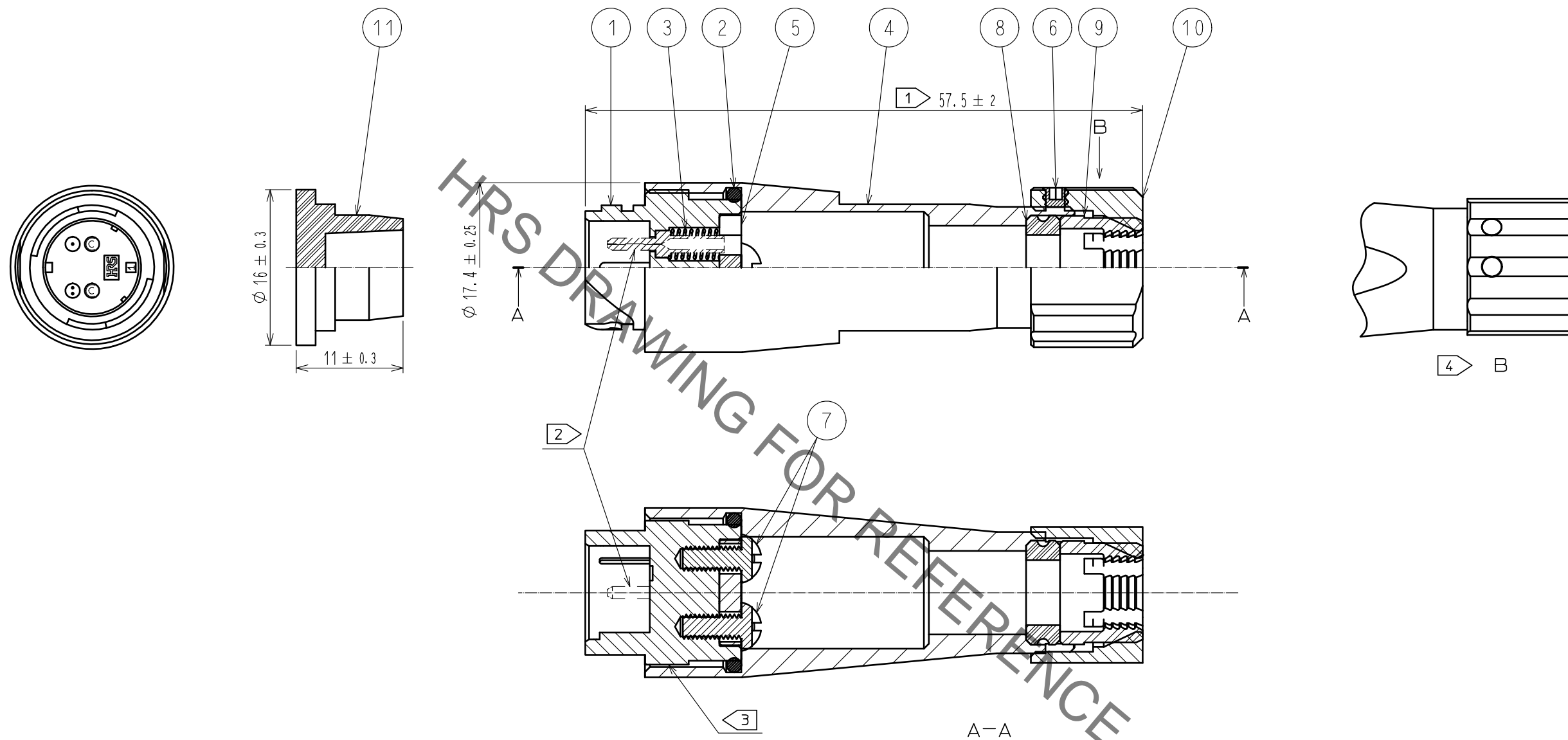

- NOTE
- 1 These are indicates the dimensions of after assembling
 - 2 Ferrules are not included in this product. MU Ferrules are sold separately.
 - 3 Apply adhesive to around the threads of R-shell-J(part No.1) before tighten Hood(part No.4).
 - 4 Clamp ring has two holes for fixing hexagon socket screw.
Tighten the screw at visible either hole with tightening torque 25N·cm. or either hole if both holes are visible.

6	STAINLESS STEEL							
5	PBT RESIN	COLOR:BLACK	11	SILICONE RUBBER	COLOR:BLACK			
4	ALUMINUM ALLOY	ANODIC OXIDE COATING	10	ZINC ALLOY DIE CASTING	NICKEL PLATING			
3	PIANO WIRE	ZINC PLATING * BAKING	9	PA RESIN	COLOR:WHITE			
2	NITRILE BUTADIENE RUBBER	COLOR:BLACK	8	CHLOROPRENE RUBBER	COLOR:BLACK			
1	ZINC ALLOY DIE CASTING	NICKEL PLATING	7	STAINLESS STEEL				
NO.	MATERIAL	FINISH . REMARKS	NO.	MATERIAL	FINISH . REMARKS			
UNITS mm		SCALE 2 : 1		COUNT	DESCRIPTION OF REVISIONS	DESIGNED	CHECKED	DATE
HRS HIROSE ELECTRIC CO., LTD.		APPROVED : MT. SHIBUTANI	18.03.28	DRAWING NO. EDC-177028-32-00				
		CHECKED : MT. SHIBUTANI	18.03.28	PART NO. MF10B-WJ6.5C01-0200(32)				
		DESIGNED : SI. MATSUMOTO	18.03.28	CODE NO. CL709-1011-7-32				
		DRAWN : SI. MATSUMOTO	18.03.28					