

Oct.1.2020 Copyright 2020 HIROSE ELECTRIC CO., LTD. All Rights Reserved.
 In case of consideration for using Automotive equipment / device which demand high reliability, kindly contact our sales window correspondents.

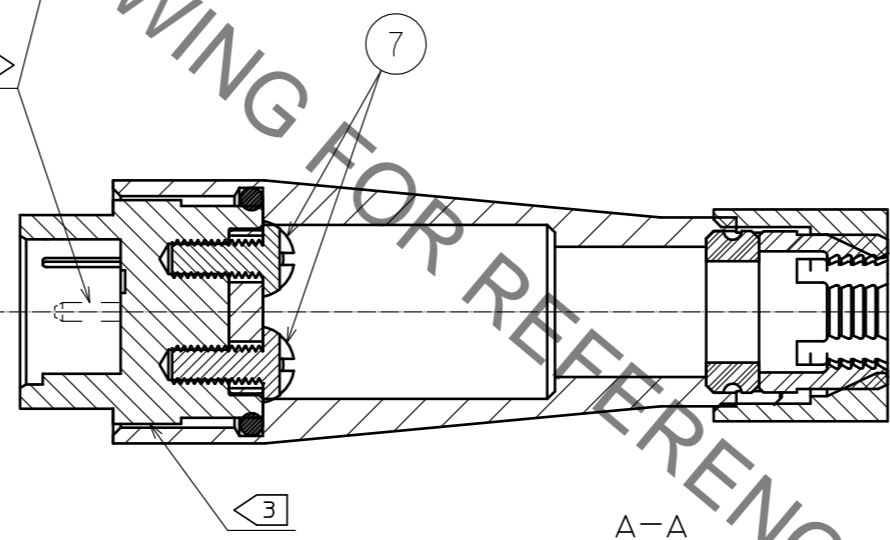
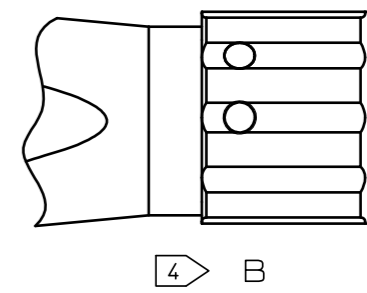
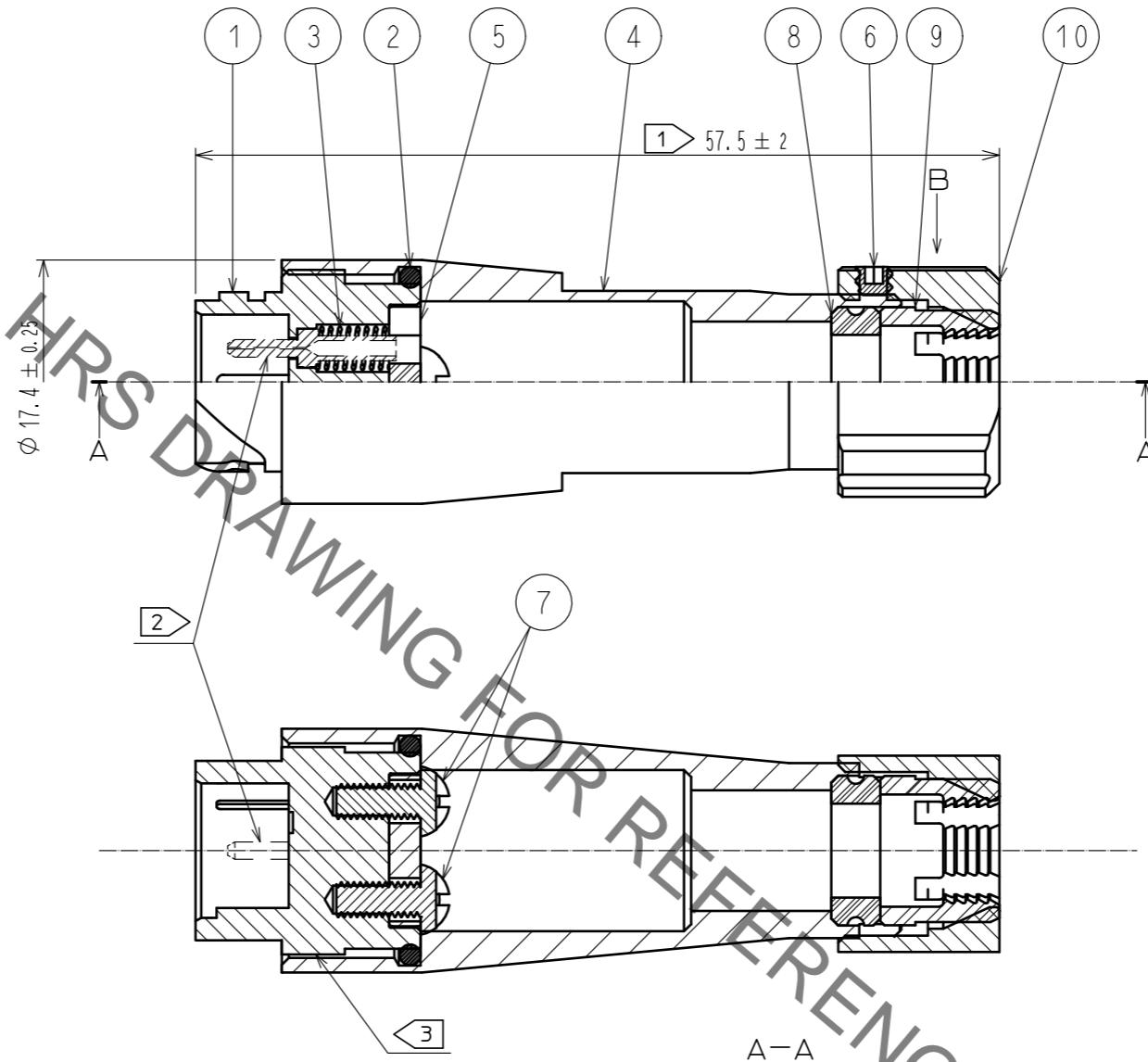
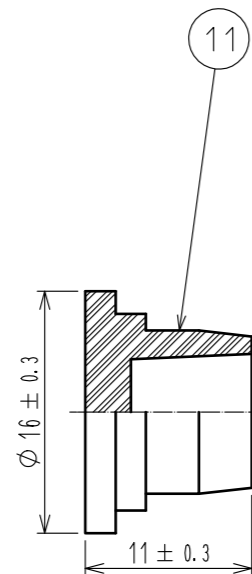
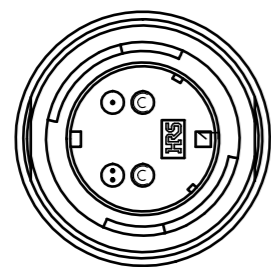

- NOTE
- 1 These are indicates the dimensions of after assembling
 - 2 Ferrules are not included in this product. MU Ferrules are sold separately.
 - 3 Apply adhesive to around the threads of R-shell-J(part No.1) before tighten Hood(part No.4).
 - 4 Clamp ring has two holes for fixing hexagon socket screw.
Tighten the screw at visible either hole with tightening torque 25N·cm. or either hole if both holes are visible.

6	STAINLESS STEEL				
5	PBT RESIN	COLOR:BLACK	11	SILICONE RUBBER	COLOR:BLACK
4	ALUMINUM ALLOY	ANODIC OXIDE COATING	10	ZINC ALLOY DIE CASTING	CHROME PLATING(COLOR:BLACK)
3	PIANO WIRE	ZINC PLATING * BAKING	9	PA RESIN	COLOR:WHITE
2	NITRILE BUTADIENE RUBBER	COLOR:BLACK	8	CHLOROPRENE RUBBER	COLOR:BLACK
1	ZINC ALLOY DIE CASTING	CHROME PLATING(COLOR:BLACK)	7	STAINLESS STEEL	
NO.	MATERIAL	FINISH . REMARKS	NO.	MATERIAL	FINISH . REMARKS

UNITS mm		SCALE 2 : 1	COUNT 	DESCRIPTION OF REVISIONS	DESIGNED	CHECKED	DATE
HIROSE ELECTRIC CO., LTD.				APPROVED : MT. SHIBUTANI 18.03.29	DRAWING NO. EDC-177477-32-00		
				CHECKED : MT. SHIBUTANI 18.03.29	PART NO. MF10B-WJ6. 5CH01-0200(32)		
				DESIGNED : SI. MATSUMOTO 18.03.29	CODE NO. CL709-1035-5-32		
				DRAWN : SI. MATSUMOTO 18.03.29	1/1		