

Aug.1.2019 Copyright 2019 HIROSE ELECTRIC CO., LTD. All Rights Reserved.
In case of consideration for using Automotive equipment / device which demand high reliability, kindly contact our sales window correspondents.

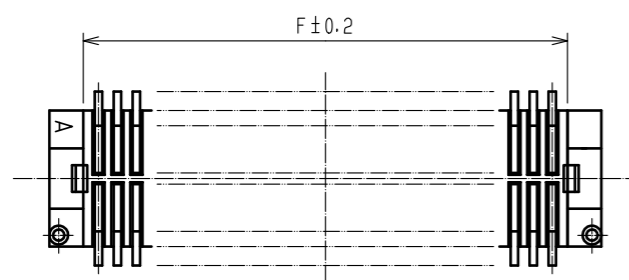

CODE No.	CONTACT	A	B	C	D	E	F
CL537-0626-9-81	10	4.6	2.0	2.7	3.1	4.1	2.8
CL537-0915-6-81	14	5.6	3.0	3.7	4.1	5.1	3.8
CL537-0628-4-81	20	7.1	4.5	5.2	5.6	6.6	5.3
CL537-0630-6-81	30	9.6	7.0	7.7	8.1	9.1	7.8
CL537-0637-5-81	32	10.1	7.5	8.2	8.6	9.6	8.3
CL537-0631-9-81	36	11.1	8.5	9.2	9.6	10.6	9.3
CL537-0632-1-81	40	12.1	9.5	10.2	10.6	11.6	10.3
CL537-0634-7-81	50	14.6	12.0	12.7	13.1	14.1	12.8
CL537-0636-2-81	60	17.1	14.5	15.2	15.6	16.6	15.3
CL537-0638-8-81	80	22.1	19.5	20.2	20.6	21.6	20.3

RECOMMENDED METAL MASK (10:1)

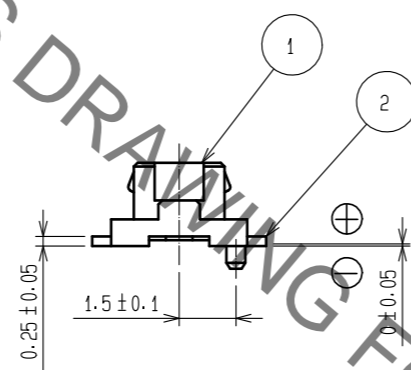
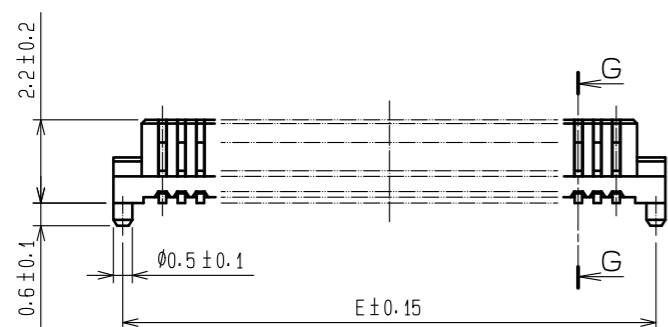
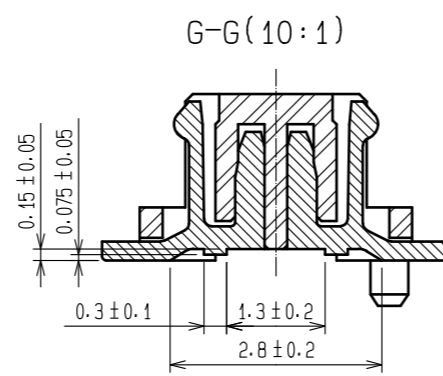
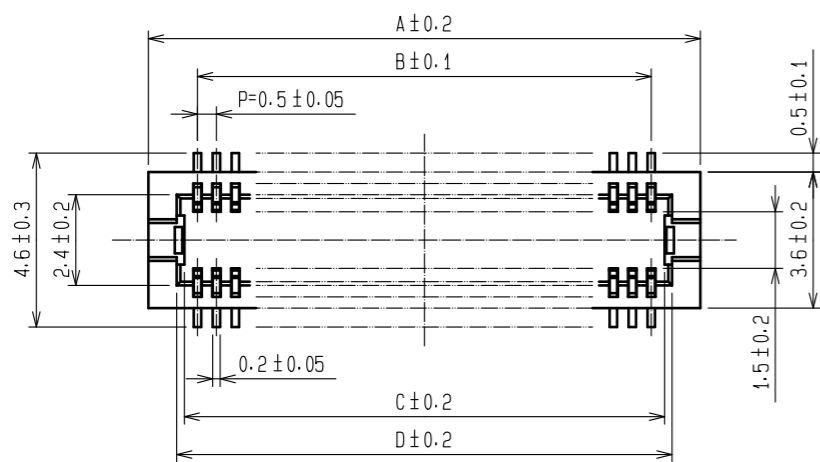
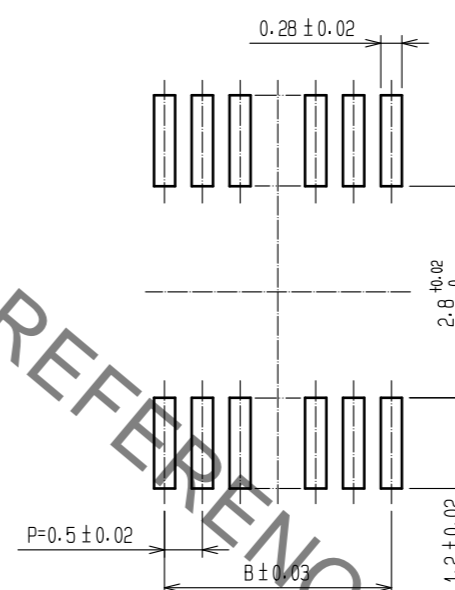

RECOMMENDED PATTERN (10:1)

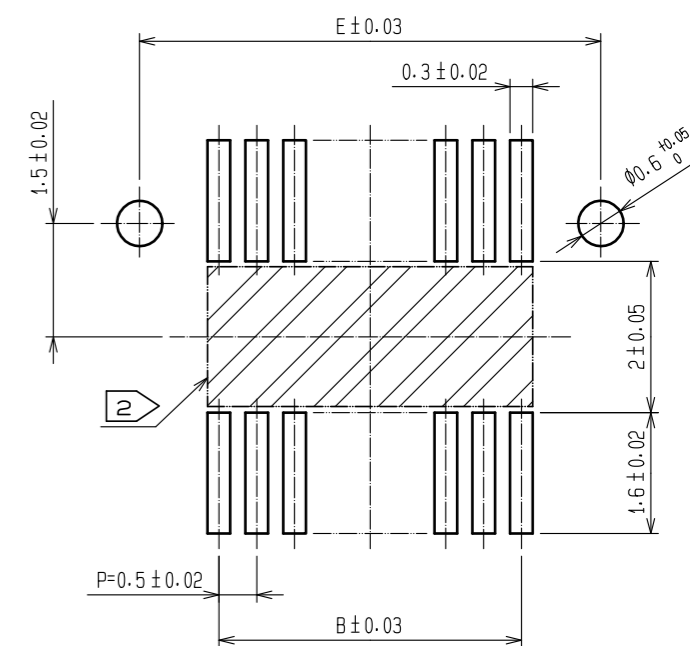

RECOMMENDED THICKNESS OF SOLDER PASTE : 120 #m

NOTES 1 : LEAD CO-PLANARITY SHALL BE 0.08 mm MAX.
2 IF THERE IS PATTERN ON PART, THERE IS A POSSIBILITY THAT IT WILL MAKE CONTACT WITH THE LEADS.

NO.	MATERIAL	FINISH . REMARKS	NO.	MATERIAL	FINISH . REMARKS
2	PHOSPHOR BRONZE	CONTACT AREA:GOLD PLATED 0.2#m min LEAD AREA:GOLD PLATED 0.015#m min OTHERS(UNDER PLATING):NICKEL PLATED 2#m min	6	PS	CLEAR (REINFORCEMENT COLLAR)
			5	PS	BLACK (PLASTIC REEL)
			4	POLYESTER	CLEAR (COVER TAPE)
1	POLYAMIDE	UL94V-0-NATURAL (BEIGE)	3	PS	CLEAR (EMBOSSED CARRIER TAPE)

UNITS	SCALE	COUNT	DESCRIPTION OF REVISIONS	DESIGNED	CHECKED	DATE
mm	5 : 1	△				

HRS HIROSE ELECTRIC CO., LTD.	APPROVED : WR. FUKUCHI	20190409	DRAWING NO.	EDC-163505-81-78
	CHECKED : WR. FUKUCHI	20190409	PART NO.	DF12A(3.0)-*DS-0.5V(81)
	DESIGNED : KT. KUSAKA	20190409	CODE NO.	CL537
	DRAWN : RN. IIDA	20190409		

Aug.1.2019 Copyright 2019 HIROSE ELECTRIC CO., LTD. All Rights Reserved.
 In case of consideration for using Automotive equipment / device which demand high reliability, kindly contact our sales window correspondents.

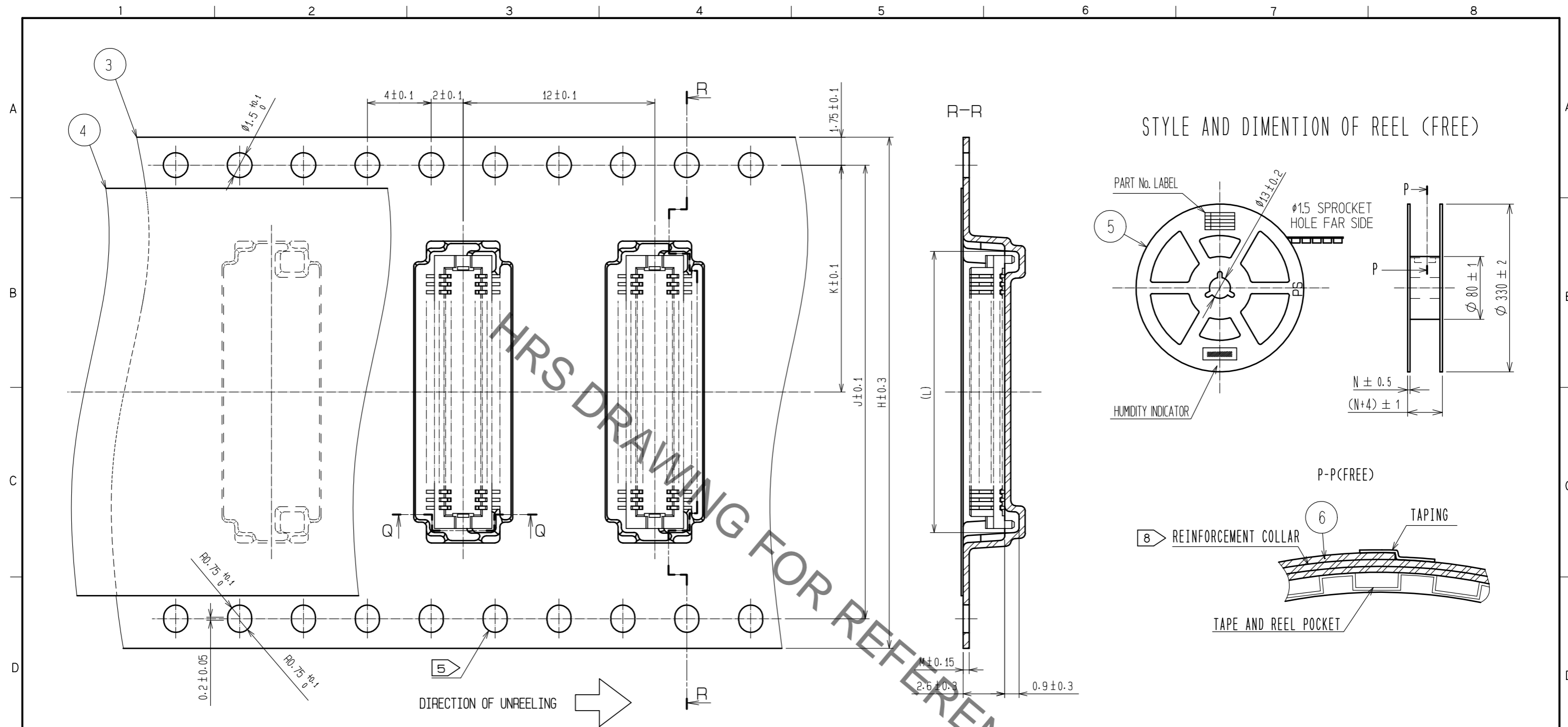

STYLE AND DIMENTION OF REEL (FREE)

CODE No.	CONTACT	H	J	K	L	M	N
CL537-0626-9-81	10	16	-	7.5	6.4	0.30	17.5
CL537-0915-6-81	14	16	-	7.5	7.4	0.30	17.5
CL537-0628-4-81	20	16	-	7.5	9	0.38	17.5
CL537-0630-6-81	30	24	-	11.5	11.5	0.38	25.5
CL537-0637-5-81	32	24	-	11.5	12	0.30	25.5
CL537-0631-9-81	36	24	-	11.5	12.6	0.38	25.5
CL537-0632-1-81	40	24	-	11.5	14	0.38	25.5
CL537-0634-7-81	50	24	-	11.5	16.1	0.38	25.5
CL537-0636-2-81	60	32	28.4	14.2	18.6	0.38	33.5
CL537-0638-8-81	80	44	40.4	20.2	23.8	0.38	45.5

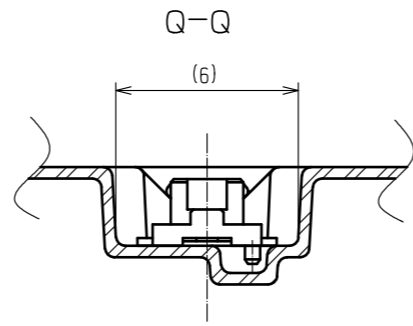

- NOTES
- 1 REEL 1000 CONNECTORS.
 - 4 AT THE BEGINNING OF THE REEL, 30 COMPONENTS SHALL BE EMPTY.
 AT THE END OF THE REEL, 20 COMPONENTS SHALL BE EMPTY.
 - 5 WHEN THE TAPE WIDTH IS 32 mm OR 44 mm, SPROCKET HOLES SHALL BE SET ON BOTH SIDE OF REEL AS SHOWN ON THIS DRAWING.
 - 6 PEEL FORCE REFERS TO JIS C 0806. (IEC 60286-3)
 - 7 SPECIAL PACKING IS APPLIED FOR THIS PRODUCT, USING POLYAMIDE RESIN, TO IMPROVE MOISTURE RESISTANCE.
 AFTER OPENING AND WHEN RESTORING IS NEEDED, PLEASE PUT THE PRODUCT WITH DESICCANT IN A SEALED ALUMINIUM BAG.
 IN CASE THE COLOR OF THE INDICATOR(30%) TURNED TO PINK, DO BAKING THE PRODUCTS(50°C, 48HOURS).
 - 8 AFTER PACKING, ROLL 2 METERS OF THE REINFORCEMENT COLLAR TO OUTER CIRCUMFERENCE OF TAPE AND REEL POCKET, AND TAPE DOWN AT THE END THE COLLAR.

HRS	DRAWING NO.	EDC-163505-81-78
	PART NO.	DF12A(3.0)-*DS-0.5V(81)
	CODE NO.	CL537
		2/2