

May.1.2019 Copyright 2019 HIROSE ELECTRIC CO., LTD. All Rights Reserved.
In case of consideration for using Automotive equipment / device which demand high reliability, kindly contact our sales window correspondents.

Contact No.1 marking

Recommended PCB layout
Recommended metal mask (thickness:0.1mm)

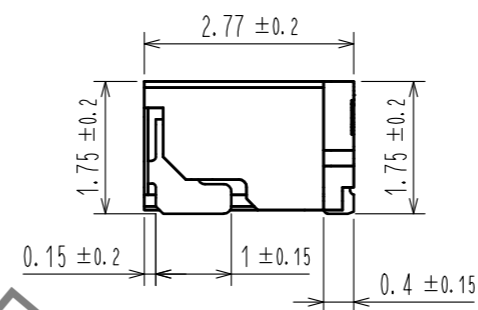
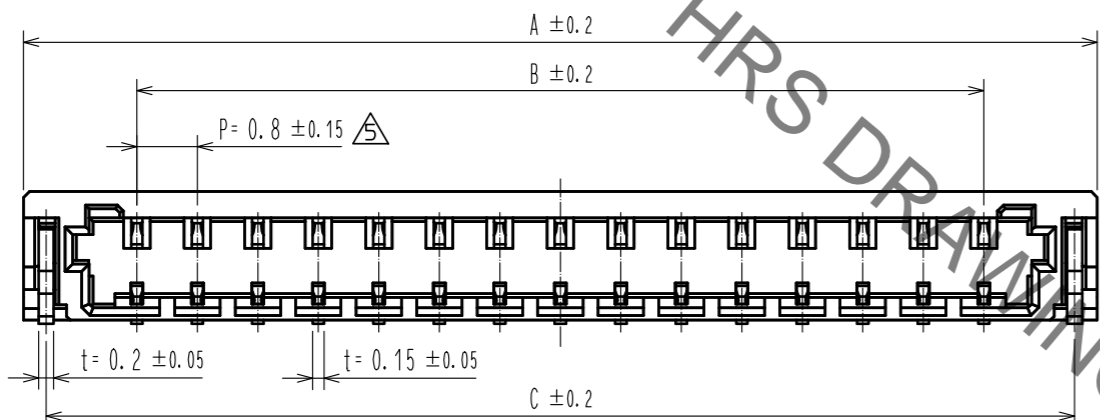
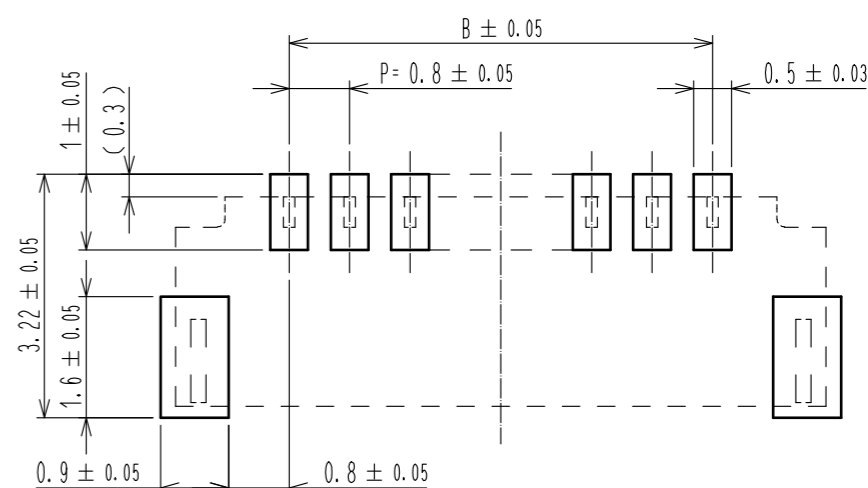
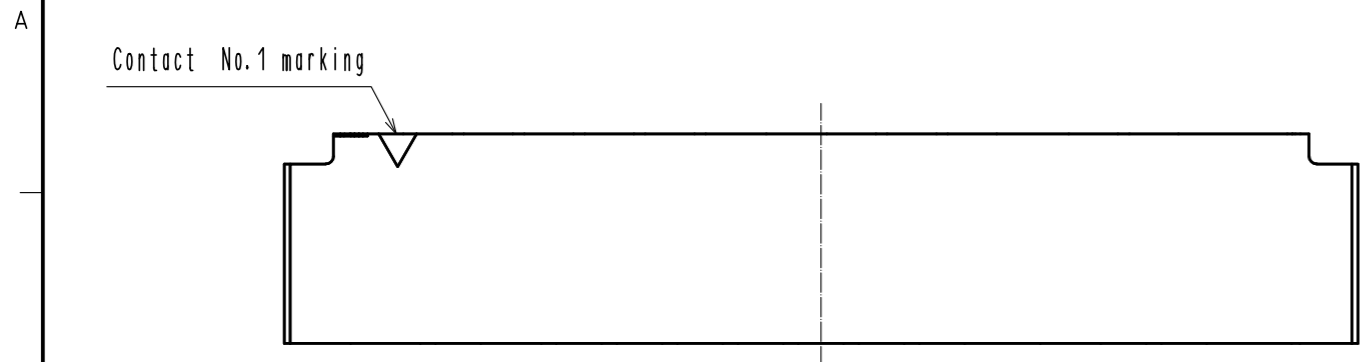

Mating Figure (Free)

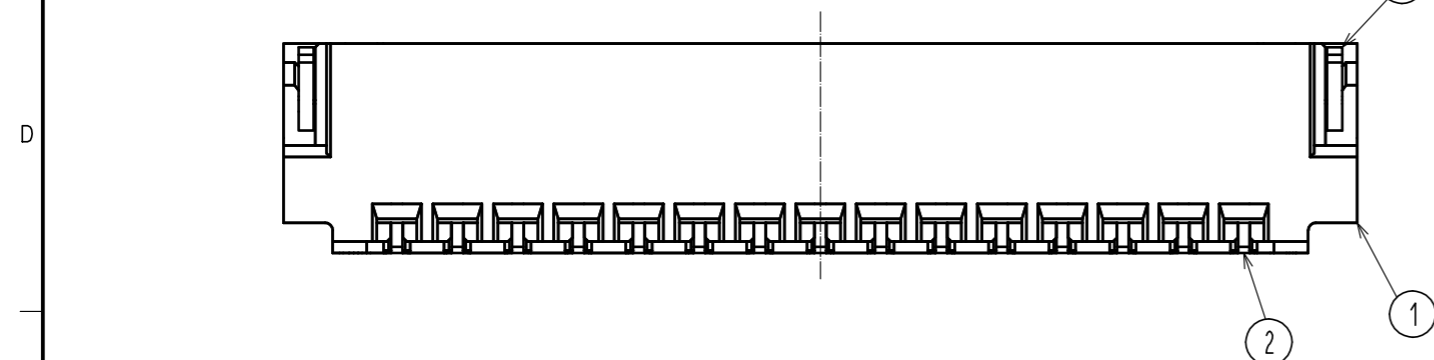
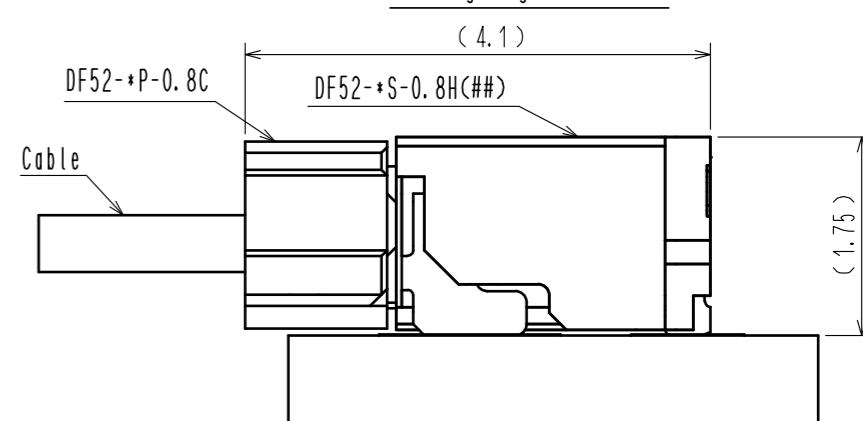

Part No.	Code No.	A	B	C
DF52-2S-0.8H(21)	CL0668-0004-5-21	3.8	0.8	3.2
DF52-3S-0.8H(21)	CL0668-0022-7-21	4.6	1.6	4.0
DF52-4S-0.8H(21)	CL0668-0005-8-21	5.4	2.4	4.8
DF52-5S-0.8H(21)	CL0668-0023-0-21	6.2	3.2	5.6
DF52-6S-0.8H(21)	CL0668-0006-0-21	7.0	4.0	6.4
DF52-8S-0.8H(21)	CL0668-0007-3-21	8.6	5.6	8.0
DF52-10S-0.8H(21)	CL0668-0008-6-21	10.2	7.2	9.6
DF52-12S-0.8H(21)	CL0668-0009-9-21	11.8	8.8	11.2
DF52-14S-0.8H(21)	CL0668-0024-2-21	13.4	10.4	12.8
DF52-15S-0.8H(21)	CL0668-0010-8-21	14.2	11.2	13.6
DF52-16S-0.8H(21)	CL0668-0025-5-21	15.0	12.0	14.4
DF52-17S-0.8H(21)	CL0668-0001-7-21	15.8	12.8	15.2
DF52-20S-0.8H(21)	CL0668-0011-0-21	18.2	15.2	17.6

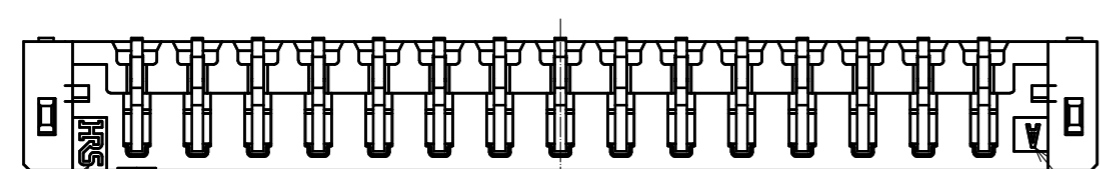

HRS marking

Cavity No.

Note 1. Lead co-planarity shall be 0.1mm MAX.
2. Please consult HIROSE when the product is mounted to FPC.

NO.	MATERIAL	FINISH . REMARKS	NO.	MATERIAL	FINISH . REMARKS
3	Brass	Surface:tin plating 1μmMIN	6	PS	Black(Reel)
2	Copper alloy	Surface:tin plating 1μmMIN	5	Polyester	Clear(Cover tape), ANTI-STATIC
1	Polyamide	Black, UL94V-0	4	PS	Clear(Embossed carrier tape), ANTI-STATIC

UNITS	SCALE	COUNT	DESCRIPTION OF REVISIONS	DESIGNED	CHECKED	DATE
mm	10:1	2	DIS-H-00003668	HK. HAYASHI	TS. FUKUSHIMA	18.03.22

APPROVED	:KI. AKIYAMA	14.06.27	DRAWING NO.	EDC3-356517-01
CHECED	:HK. UMEHARA	14.06.27	PART NO.	DF52-*S-0.8H(21)
DESIGNED	:TH. YOSHIZAWA	14.06.26	CODE NO.	CL668-
DRAWN	:TH. YOSHIZAWA	14.06.26		

May.1.2019 Copyright 2019 HIROSE ELECTRIC CO., LTD. All Rights Reserved.
In case of consideration for using Automotive equipment / device which demand high reliability, kindly contact our sales window correspondents.

Drawing for packing (Free)

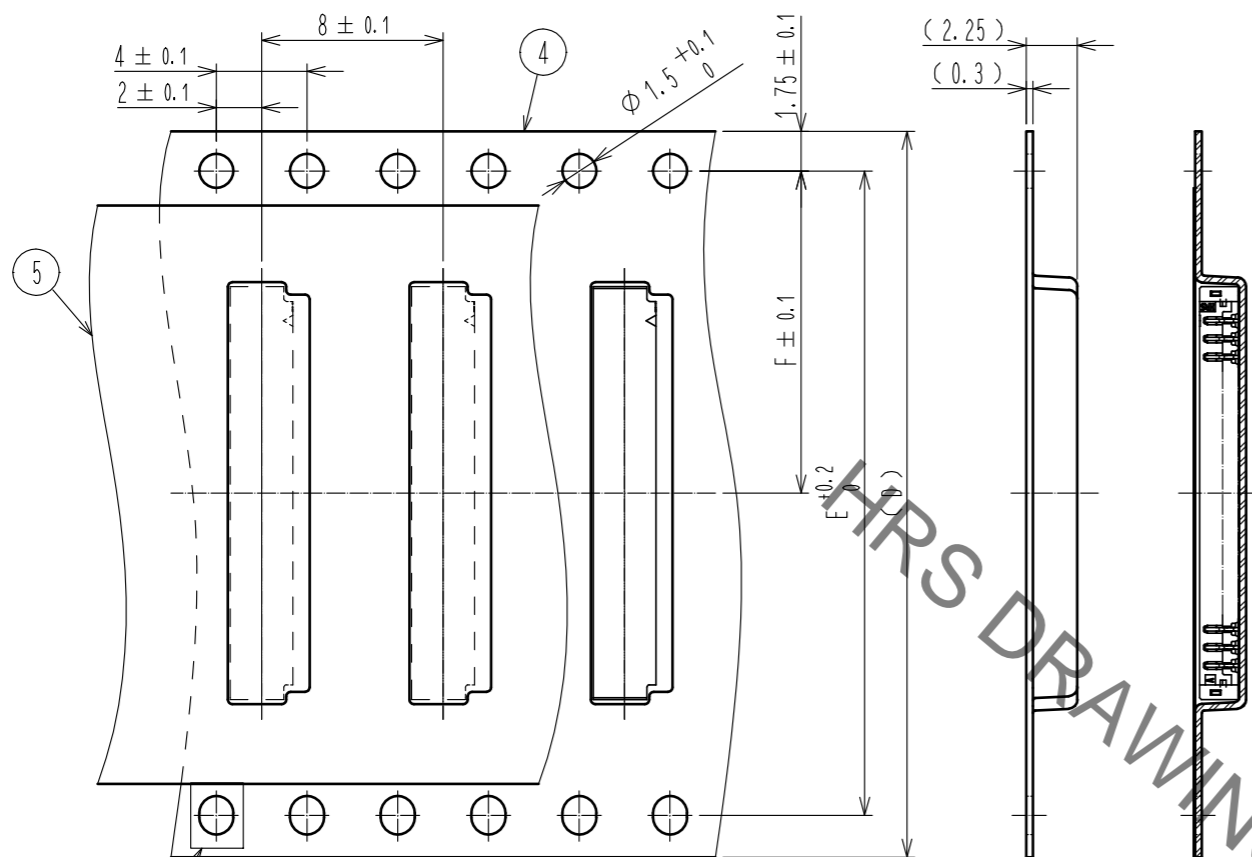

Direction of unreeling



Taping (Free)

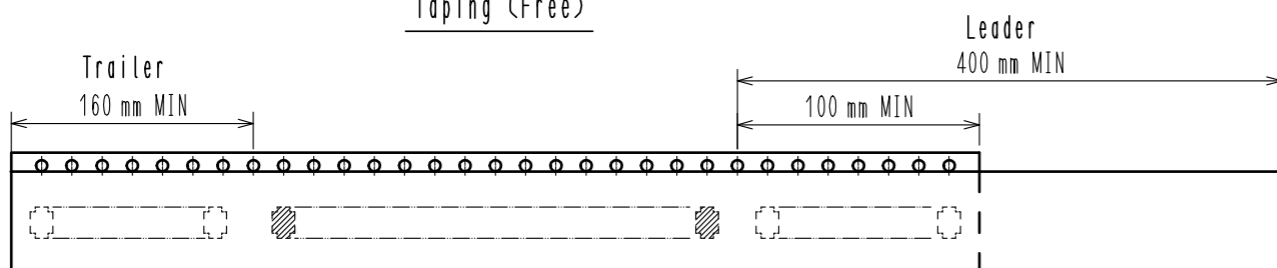

Empty components Portion equipped connectors Empty components

Style and dimension of reel (Free)

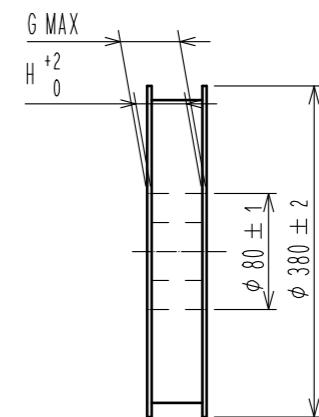
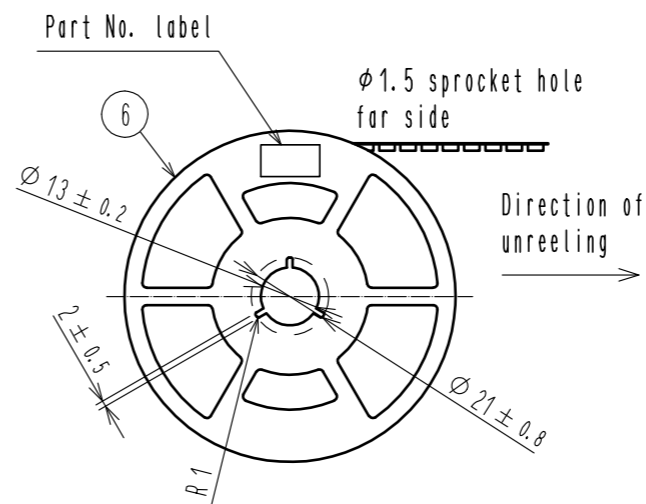

Detail of part No. label

Lot No.	170 7010	◀ 7
CL Code	CL668-0001-7-21	
品名 (Part Number)	DF52-17S-0.8H(21)	
納入数量 (Qty)	5000 K0	
ヒロセ電機(株)		

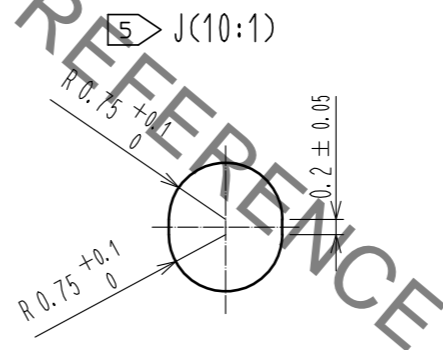

Reflow temperature profile using lead-free solder paste (Reference)

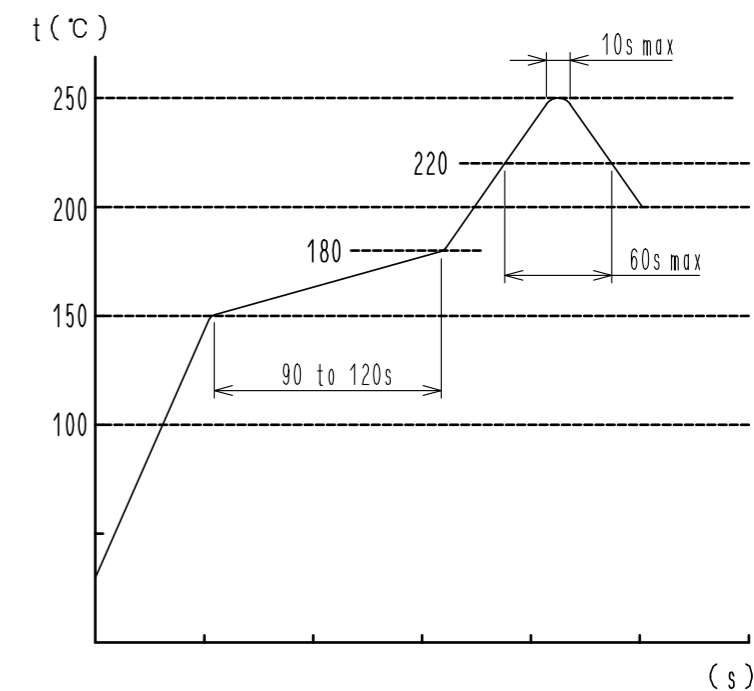

Number of reflow cycles 2 cycles MAX.
The temperature is measured in the terminal lead part.

Additional factors, such as solder paste type, PCB size and other mounted components could affect the profile, therefore, a thorough evaluation of mounting condition is required prior to production.

- Note
3. 1reel:5000 connectors.
 4. () is reference dimension.
 - 5 When the tape width is 32mm, sprocket holes shall be set on both side of reel as shown on this drawing.
 - 6 Refer to JIS C 0806. (Packaging of components for automating handling)
 - 7 Each meaning of Lot No. are shown below.

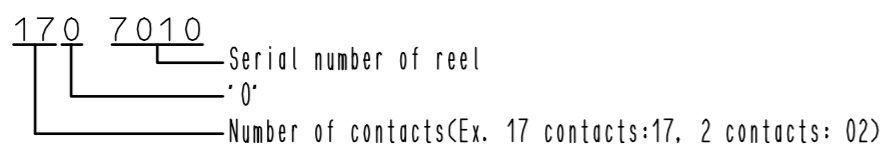

Part No.	Code No.	D	E	F	G	H
DF52-2S-0.8H(21)	CL0668-0004-5-21	16.0	/	7.5	22.4	16.4
DF52-3S-0.8H(21)	CL0668-0022-7-21	16.0	/	7.5	22.4	16.4
DF52-4S-0.8H(21)	CL0668-0005-8-21	16.0	/	7.5	22.4	16.4
DF52-5S-0.8H(21)	CL0668-0023-0-21	16.0	/	7.5	22.4	16.4
DF52-6S-0.8H(21)	CL0668-0006-0-21	16.0	/	7.5	22.4	16.4
DF52-8S-0.8H(21)	CL0668-0007-3-21	24.0	/	11.5	30.4	24.4
DF52-10S-0.8H(21)	CL0668-0008-6-21	24.0	/	11.5	30.4	24.4
DF52-12S-0.8H(21)	CL0668-0009-9-21	24.0	/	11.5	30.4	24.4
DF52-14S-0.8H(21)	CL0668-0024-2-21	24.0	/	11.5	30.4	24.4
DF52-15S-0.8H(21)	CL0668-0010-8-21	24.0	/	11.5	30.4	24.4
DF52-16S-0.8H(21)	CL0668-0025-5-21	24.0	/	11.5	30.4	24.4
DF52-17S-0.8H(21)	CL0668-0001-7-21	24.0	/	11.5	30.4	24.4
DF52-20S-0.8H(21)	CL0668-0011-0-21	32.0	28.4	14.2	38.4	32.4

HRS	DRAWING NO.	EDC3-356517-01
	PART NO.	DF52-*S-0.8H(21)
	CODE NO.	CL668-