

May.1.2022 Copyright 2022 HIROSE ELECTRIC CO., LTD. All Rights Reserved.
In case of consideration for using Automotive equipment / device which demand high reliability, kindly contact our sales window correspondents.

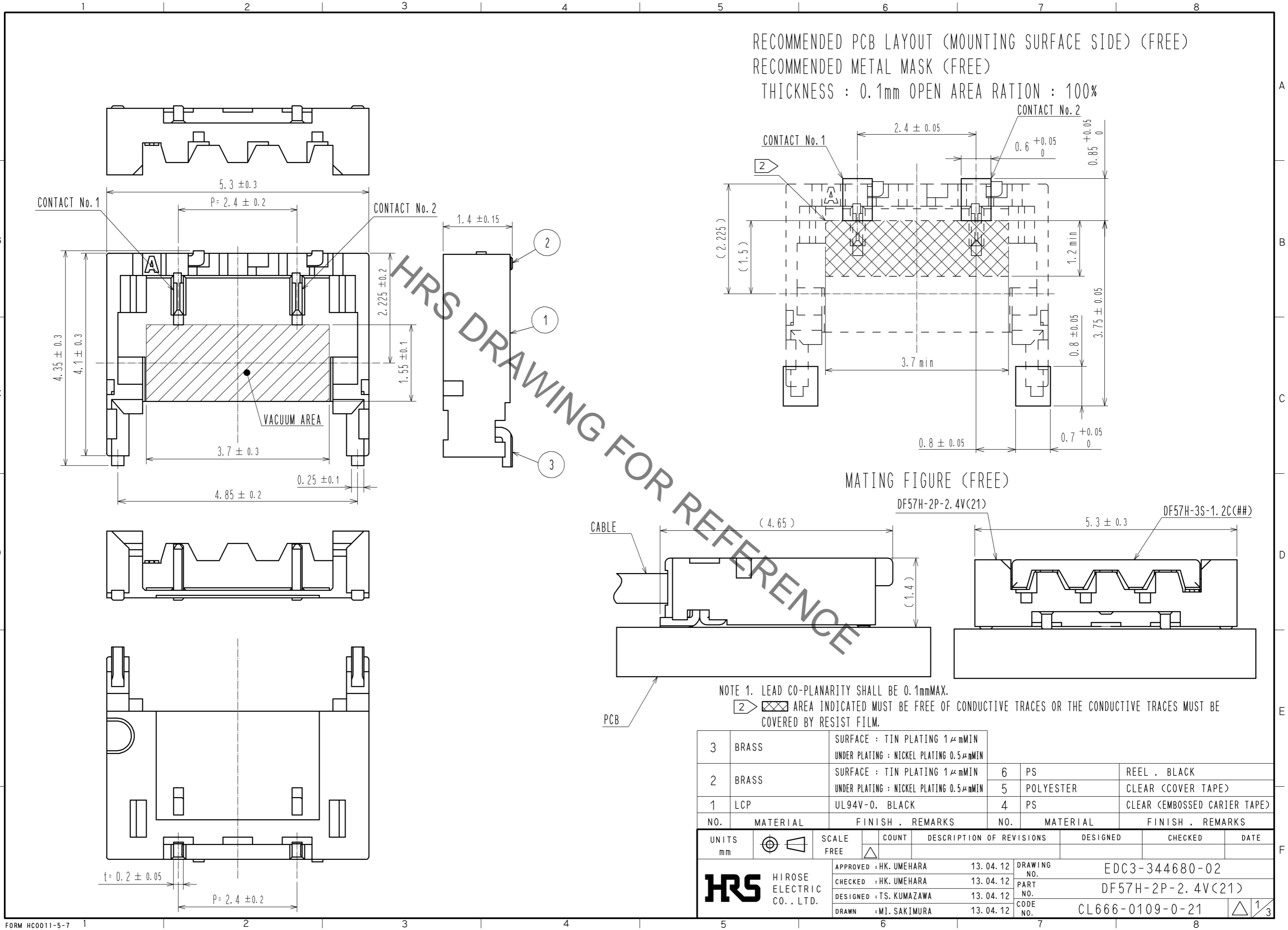

RECOMMENDED PCB LAYOUT (MOUNTING SURFACE SIDE) (FREE)
RECOMMENDED METAL MASK (FREE)
THICKNESS : 0.1mm OPEN AREA RATION : 100%

MATING FIGURE (FREE)

NOTE 1. LEAD CO-PLANARITY SHALL BE 0.1mmMAX.
② AREA INDICATED MUST BE FREE OF CONDUCTIVE TRACES OR THE CONDUCTIVE TRACES MUST BE COVERED BY RESIST FILM.

3	BRASS	SURFACE : TIN PLATING 1μmMIN UNDER PLATING : NICKEL PLATING 0.5μmMIN	6	PS	REEL . BLACK
2	BRASS	SURFACE : TIN PLATING 1μmMIN UNDER PLATING : NICKEL PLATING 0.5μmMIN	5	POLYESTER	CLEAR (COVER TAPE)
1	LCP	UL94V-0, BLACK	4	PS	CLEAR (EMBOSSED CARRIER TAPE)
NO.	MATERIAL	FINISH . REMARKS	NO.	MATERIAL	FINISH . REMARKS
UNITS mm		SCALE FREE	COUNT	DESCRIPTION OF REVISIONS	
HIROSE ELECTRIC CO., LTD.		APPROVED : HK. UMEHARA	13. 04. 12	DRAWING NO. EDC3-344680-02	
		CHECKED : HK. UMEHARA	13. 04. 12	PART NO. DF57H-2P-2. 4V(21)	
		DESIGNED : TS. KUMAZAWA	13. 04. 12	CODE NO. CL666-0109-0-21	
		DRAWN : MI. SAKIMURA	13. 04. 12	1/3	

May.1.2022 Copyright 2022 HIROSE ELECTRIC CO., LTD. All Rights Reserved.
 In case of consideration for using Automotive equipment / device which demand high reliability, kindly contact our sales window correspondents.

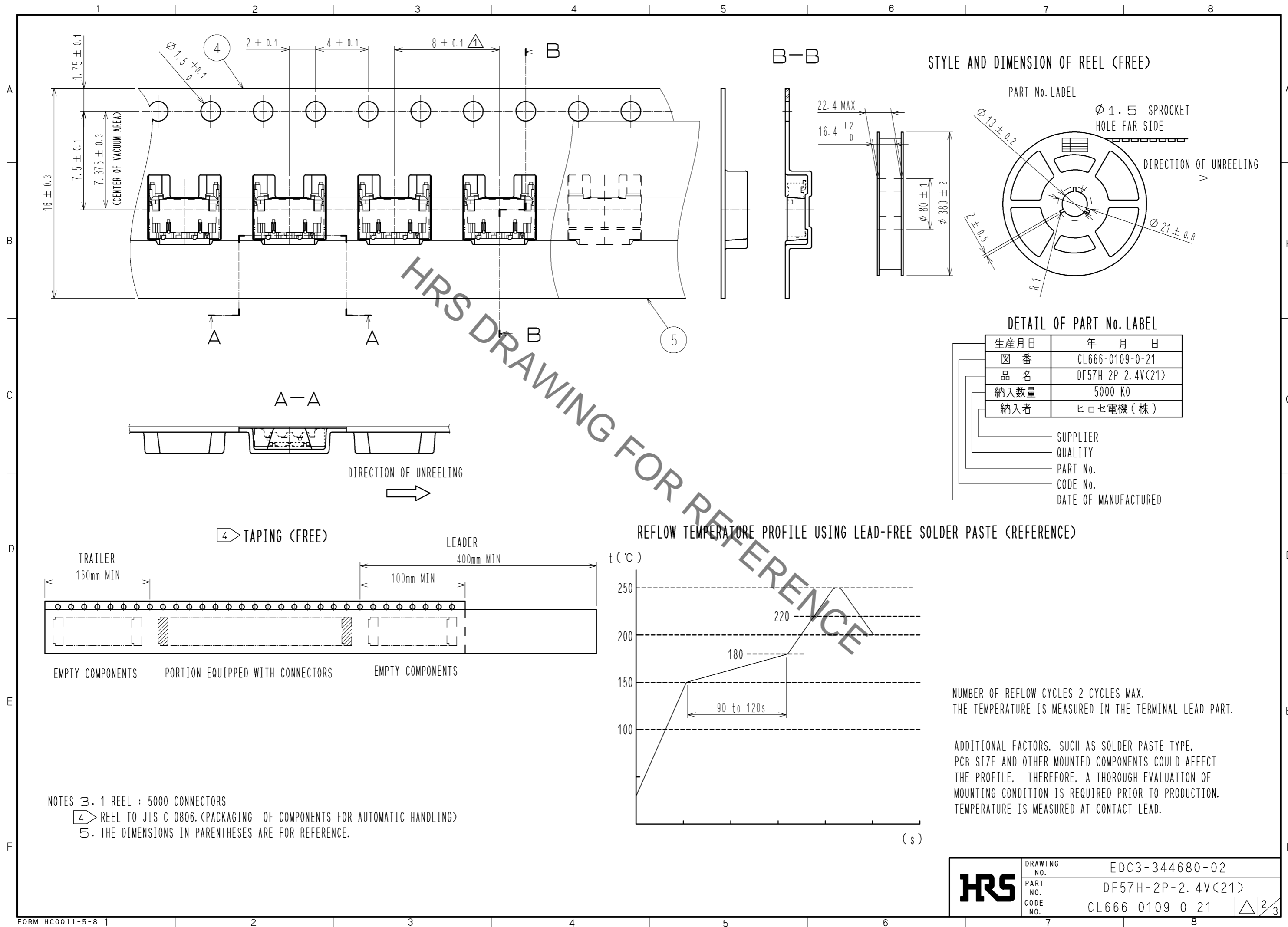

HRS	DRAWING NO.	EDC3-344680-02
	PART NO.	DF57H-2P-2.4V(21)
	CODE NO.	CL666-0109-0-21
		△ 2/3

DF57 Series Mating / Unmating Operation Instruction

Mating

① By positioning the convexity of the socket sides to the header concavity, align the centers of the socket and the header in pitch direction.

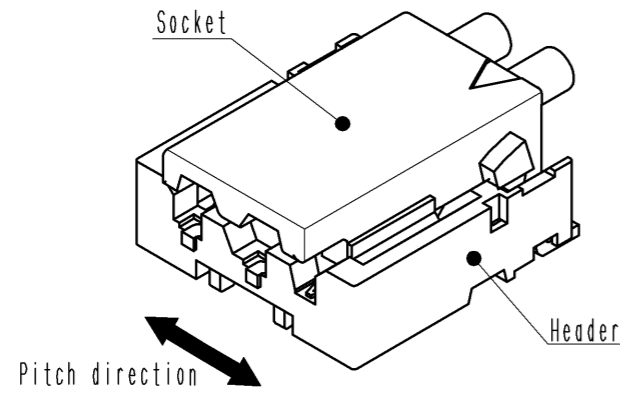

② Slightly press the socket down at cable side to tilted angle.

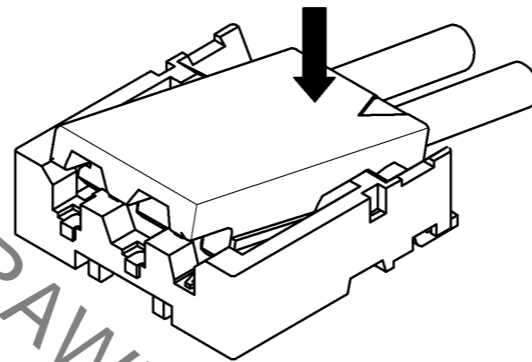

③ Press down at the lever side with stabilizing the cable side to insert. Mating completes.

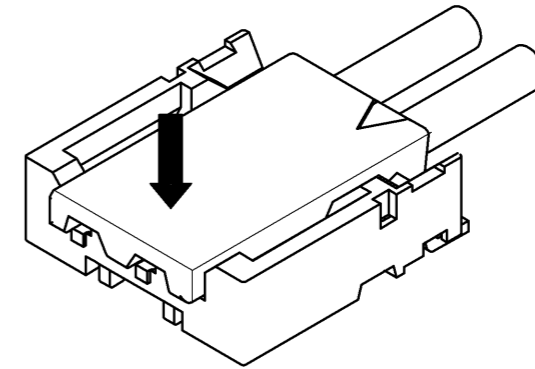

Unmating

① Hook the lever with finger nail.

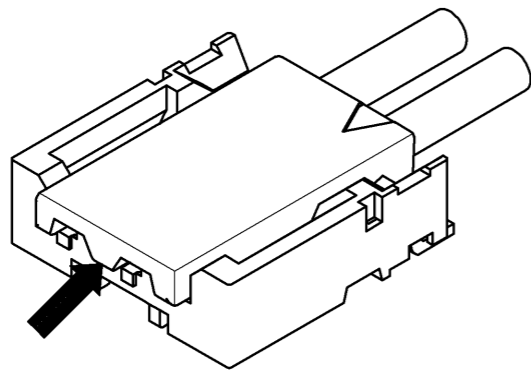

② Lift up to the upper direction and friction lock is released.

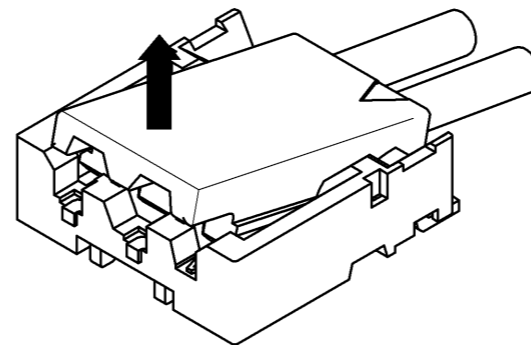

③ Lift up to the upper direction and positive lock is released. Removal completes.

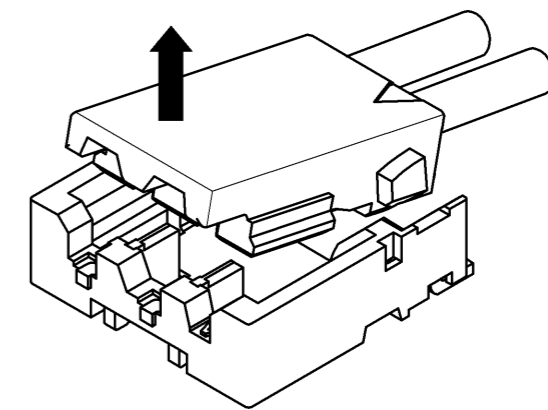

HRS DRAWING FOR REFERENCE

HRS	DRAWING NO.	EDC3-344680-02
	PART NO.	DF57H-2P-2.4V(21)
	CODE NO.	CL666-0109-0-21
		△ 3/3

May.1.2022 Copyright 2022 HIROSE ELECTRIC CO., LTD. All Rights Reserved. In case of consideration for using Automotive equipment / device which demand high reliability, kindly contact our sales window correspondents.