

Dec.1.2019 Copyright 2019 HIROSE ELECTRIC CO., LTD. All Rights Reserved.
In case of consideration for using Automotive equipment / device which demand high reliability, kindly contact our sales window correspondents.

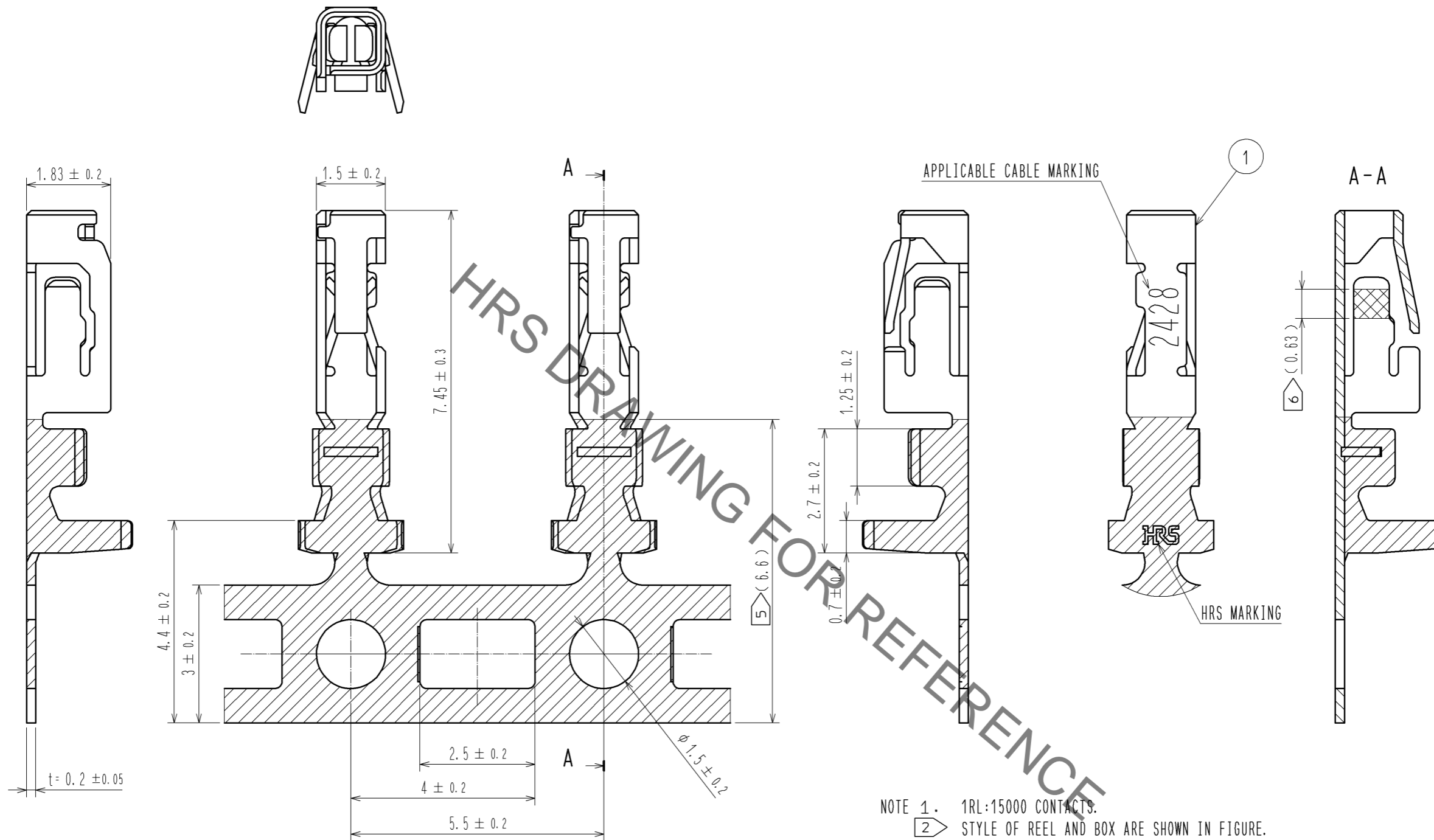

- NOTE 1. 1RL:15000 CONTACTS.
 2. STYLE OF REEL AND BOX ARE SHOWN IN FIGURE.
 3. A MAXIMUM OF 5 REELS ARE PACKED UP IN ONE BOX.
 4. PLEASE BE SURE TO CHECK THE FORM OF CRIMPING USING A CABLE. WHEN YOU ADJUST APPLICATOR.
 5. TIN PLATING AREA.
 6. GOLD PLATING AREA.
 7. THE DIMENSIONS IN PARENTHESIS ARE FOR REFERENCE.

2. STYLE AND DIMENSION OF REEL

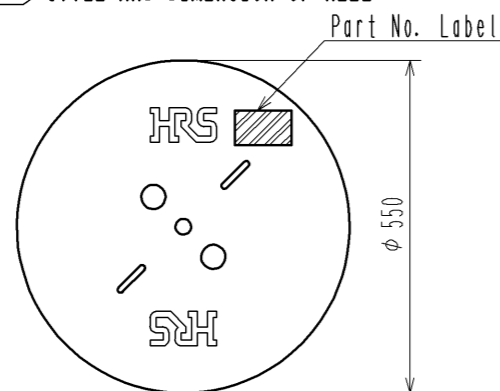

Detail of part No. Label

HRS		検査
品名コード	CL544-0500-9	Inspection
品名	DF62-2428SCFA	
数量	15000	
仕様		
LOT No.		
継ぎ目		

Section
Lot No.
Specification
Quantity
Part No.
Code No.

NO.	MATERIAL	FINISH . REMARKS	NO.	MATERIAL	FINISH . REMARKS
1	PHOSPHOR BRONZE				CONTACT AREA : GOLD PLATING 0.2 μm MIN CARRIER/BARREL AREA : TIN PLATING 1 μm MIN OTHERS : NICKEL PLATING 0.5 μm MIN

UNITS	SCALE	COUNT	DESCRIPTION OF REVISIONS	DESIGNED	CHECKED	DATE
mm	10 : 1	△				
HRS HIROSE ELECTRIC CO., LTD.			APPROVED : KI. AKIYAMA	12.01.20	DRAWING NO. EDC3-339721-00	
			CHECED : MN. KENJO	12.01.20	PART NO. DF62-2428SCFA	
			DESIGNED : TO. HORII	12.01.20	CODE NO. CL544-0500-9-00	
			DRAWN : TO. HORII	12.01.20	1/1	