

Sep.1.2021 Copyright 2021 HIROSE ELECTRIC CO., LTD. All Rights Reserved.
In case of consideration for using Automotive equipment / device which demand high reliability, kindly contact our sales window correspondents.

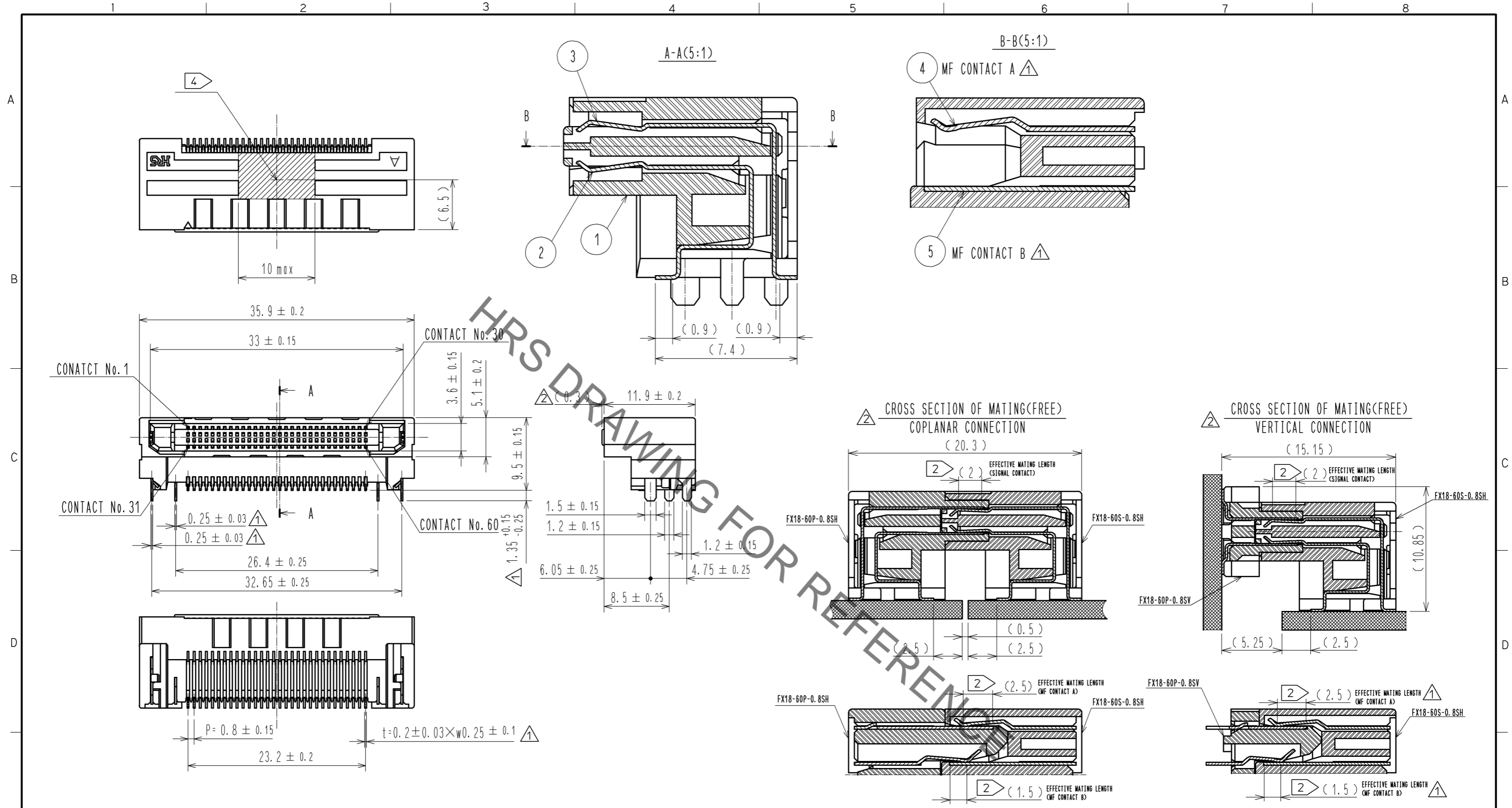

NOTE 1 LEAD CO-PLANARITY IS 0.1mm MAX.
 ① ② CONTACTS ARE 3 STEPS SEQUENTIAL. (MF CONTACT A=>SIGNAL CONTACT=>MF CONTACT B) WHEN USING THIS SEQUENTIAL STRUCTURE. PLEASE AVOID ANGLED INSERTION.
 ③ MF CONTACT A AND MF CONTACT B CAN BE USED AS POWER SUPPLY CONTACT. (3A/PIN MAX)
 ④ IT SHOWS CONNECTOR'S CENTRE OF GRAVITY AND VACUUM PICKUP AREA.
 ⑤ THIS IS PACKAGED IN TRAY. (60psc/TRAY)
 6 BLEMISH AND HIT MARK CAN BE OCCURED THROUGH OUT THE MANUFACTURING PROCESS WHICH DOESN'T AFFECT QUALITY LEVEL.
 7 THE DIMENSIONS IN PARENTHESES ARE FOR REFERENCES.

NO.	MATERIAL	FINISH	REMARKS	NO.	MATERIAL	FINISH	REMARKS
3	PHOSPHOR BRONZE	CONTACT AREA:GOLD 0.1µm LEAD AREA:GOLD 0.03µm UNDER PLATING:NICKEL 1.3µm ①		6	POLYSTYRENE		
2	PHOSPHOR BRONZE	CONTACT AREA:GOLD 0.1µm LEAD AREA:GOLD 0.03µm UNDER PLATING:NICKEL 1.3µm ①		5	PHOSPHOR BRONZE	CONTACT AREA:GOLD 0.1µm LEAD AREA:TIN-PLATING 1µm UNDER PLATING:NICKEL 1.3µm ①	
1	POLYAMIDE	BLACK UL94V-0		4	PHOSPHOR BRONZE	CONTACT AREA:GOLD 0.1µm LEAD AREA:TIN-PLATING 1µm UNDER PLATING:NICKEL 1.3µm ①	

UNITS	SCALE	COUNT	DESCRIPTION OF REVISIONS	DESIGNED	CHECKED	DATE
mm	2 : 1	7	DIS-F-005578	TH. SANO	KI. HIROKAWA	11.07.21

APPROVED	CHECED	DESIGNED	DRAWN	DRAWING NO.	PART NO.	CODE NO.
HS. OKAWA 09.04.24	HS. OZAWA 09.04.24	KI. HIROKAWA 09.04.24	KI. HIROKAWA 09.04.24	EDC3-159082-00	FX18-60S-0.8SH	CL579-0010-3-00

Sep.1.2021 Copyright 2021 HIROSE ELECTRIC CO., LTD. All Rights Reserved.
In case of consideration for using Automotive equipment / device which demand high reliability, kindly contact our sales window correspondents.

RECOMMENDED LAND PATTERN DIMENSION OF PCB(2:1)
 (PCB THICKNESS:t=1.6mm METAL MASK THICKNESS:t=0.12mm)

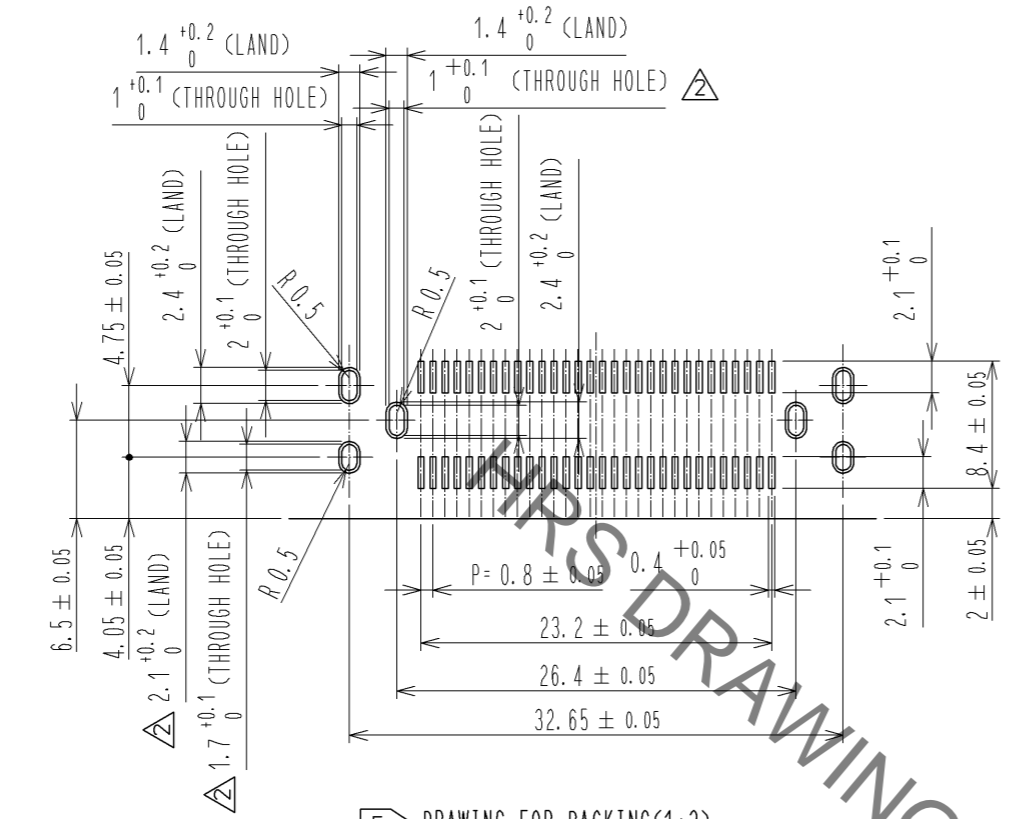

8 CONFIGURATION OF MF CONTACT A

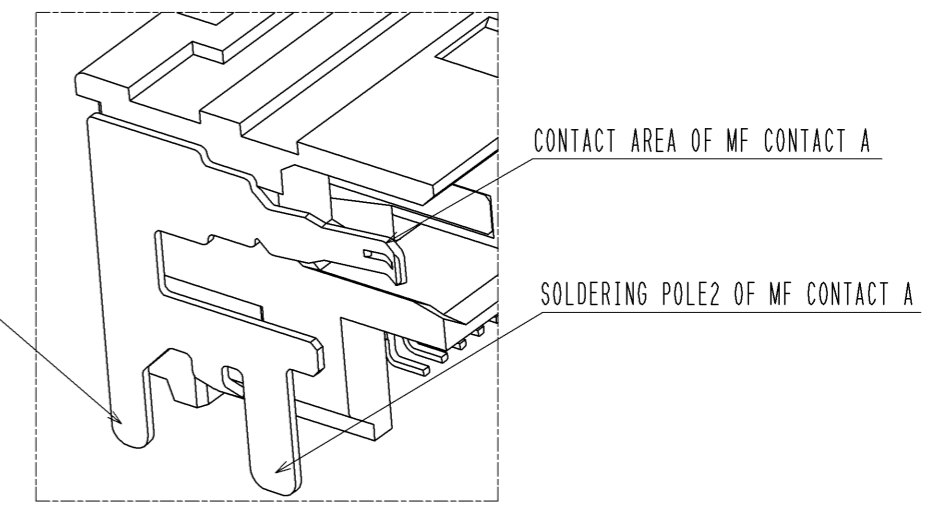

NOTE 8 SOLDERING LEAD OF MF CONTACT A SPLITS INTO TWO POLES.
BE SURE TO CONNECT TO THE SAME CIRCUIT.

5 DRAWING FOR PACKING(1:2)

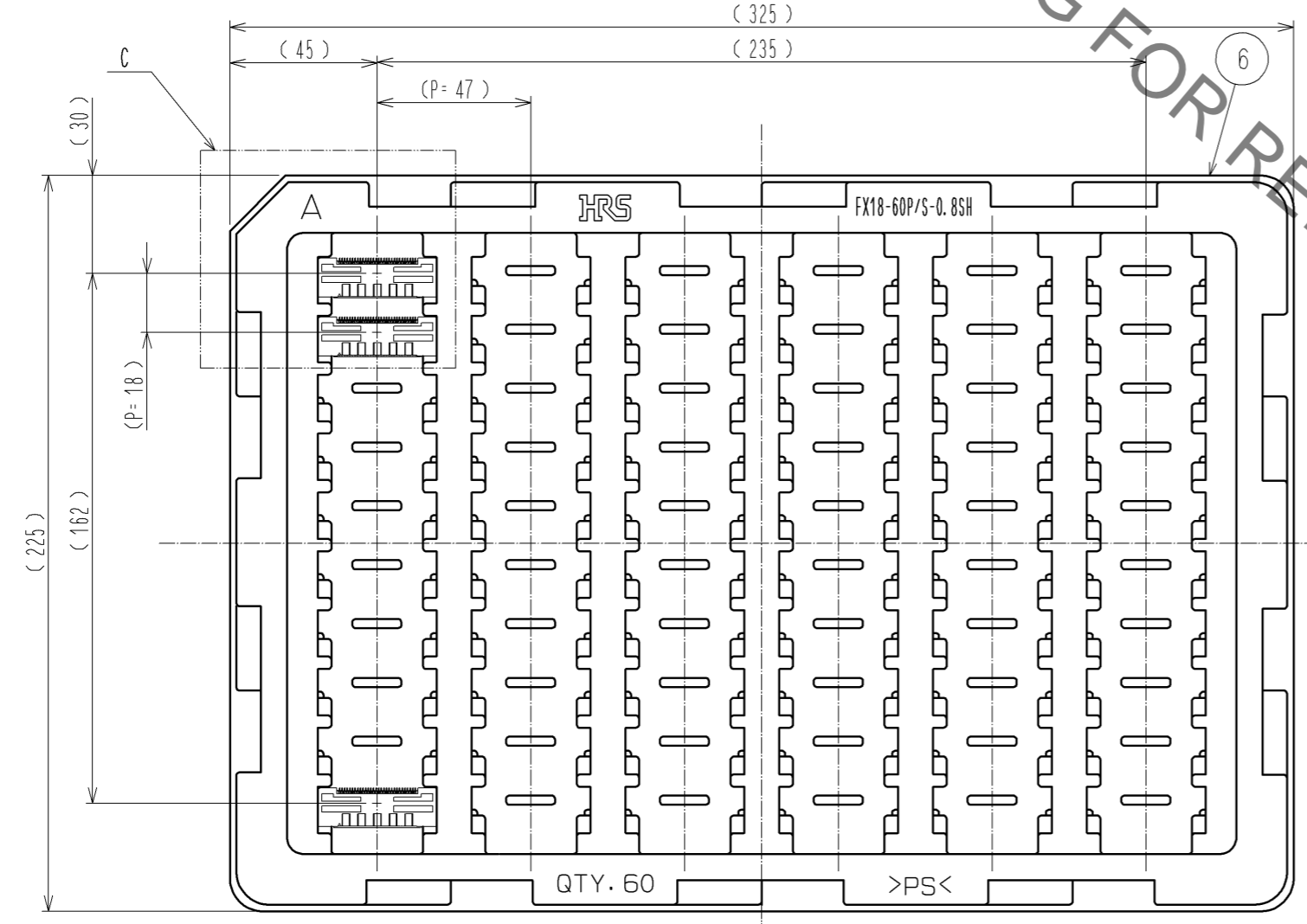

6

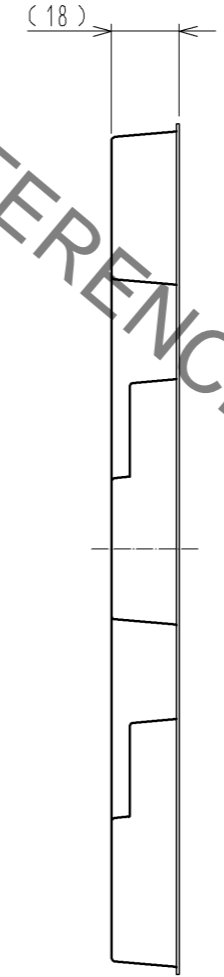

C(1:1)

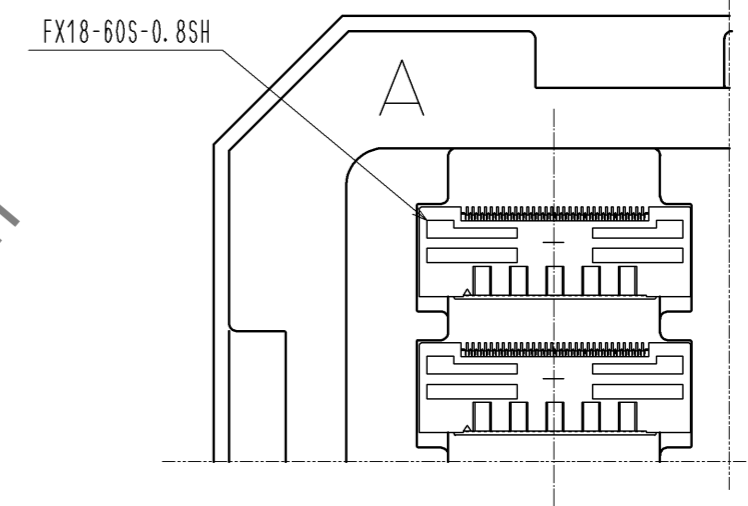

HRS	DRAWING NO.	EDC3-159082-00	2/2
	PART NO.	FX18-60S-0.8SH	
	CODE NO.	CL579-0010-3-00	