

Jun.1.2026 Copyright 2026 HIROSE ELECTRIC CO., LTD. All Rights Reserved.
In case of consideration for using Automotive equipment / device which demand high reliability, kindly contact our sales window correspondents.

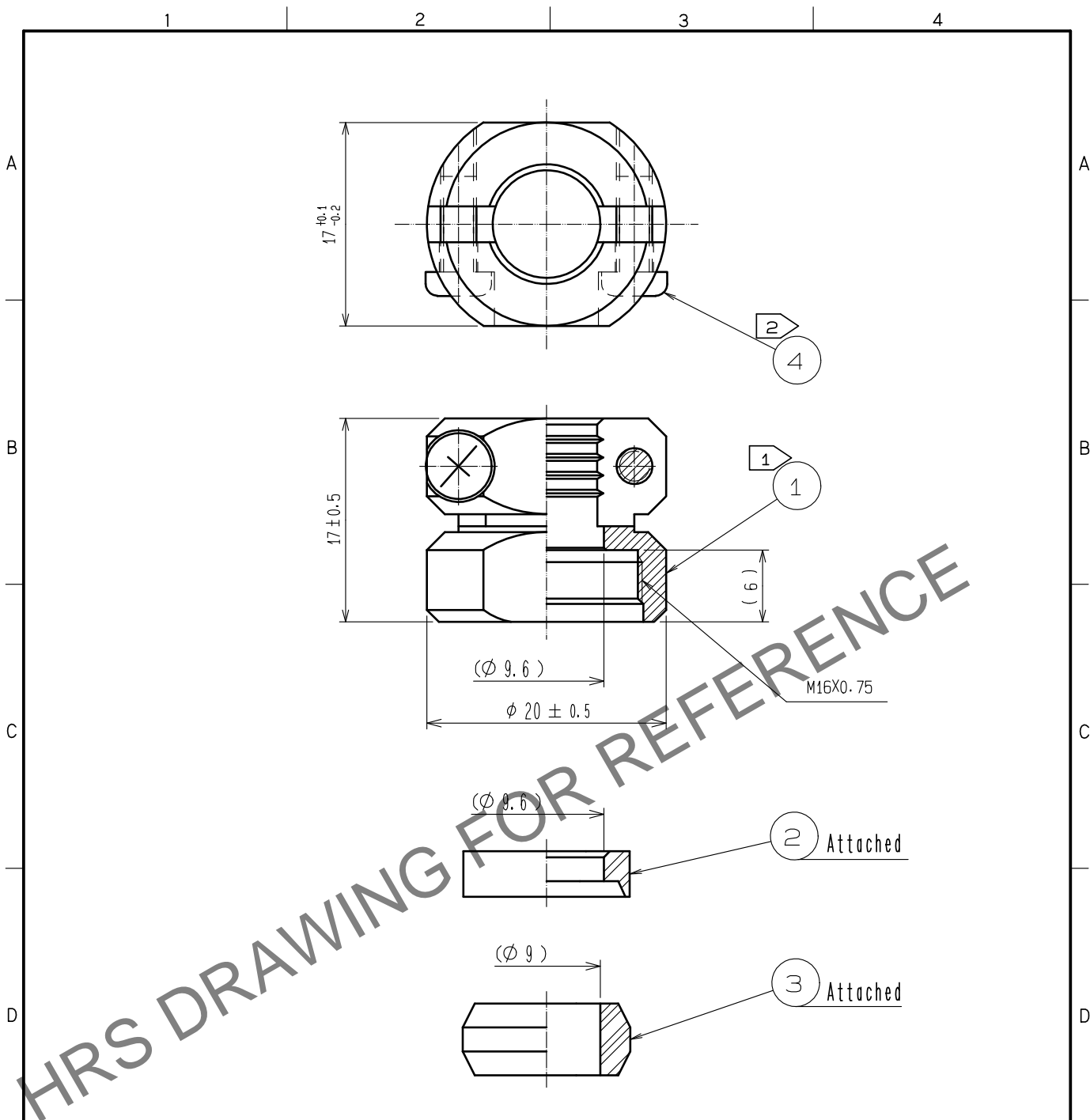

- Notes
- ① The recommended clamp torque of REF. No. ① to be 2 to 2.5 N·m. LOCTITE 263, HENKEL JAPAN or equivalent is recommended to prevent REF. No. ① from loosening.
 - ② The recommended clamp torque of REF. No. ④ to be 0.65 to 0.7 N·m.
 - ③ Sealing and airtightness and oil resisting shall be tested under mated condition with an applicable connector.

2	POLYPHENYLENE SULFIDE (BLACK)	UL94V-0	4	STAINLESS STEEL	M3×0.5×8		
1	BRASS	NICKEL PLATING	3	ACRYLONITRILE BUTADIENE RUBBER (GRAY)			
NO.	MATERIAL	FINISH . REMARKS	NO.	MATERIAL	FINISH . REMARKS		
UNITS mm		SCALE 2 : 1	COUNT 	DESCRIPTION OF REVISIONS	DESIGNED	CHECKED	DATE
HIROSE ELECTRIC CO., LTD.	APPROVED	·HY. KOBAYASHI	18.02.26	DRAWING NO.	EDC-110599-32-00		
	CHECKED	·HY. KOBAYASHI	18.02.26	PART NO.	JR13WCC-9(32)		
	DESIGNED	·TH. KAMEYA	18.02.23	CODE NO.	CL114-2050-0-32		
	DRAWN	·MK. INOUE	18.02.13		1/1		