

Dec.1.2019 Copyright 2019 HIROSE ELECTRIC CO., LTD. All Rights Reserved.
 In case of consideration for using Automotive equipment / device which demand high reliability, kindly contact our sales window correspondents.

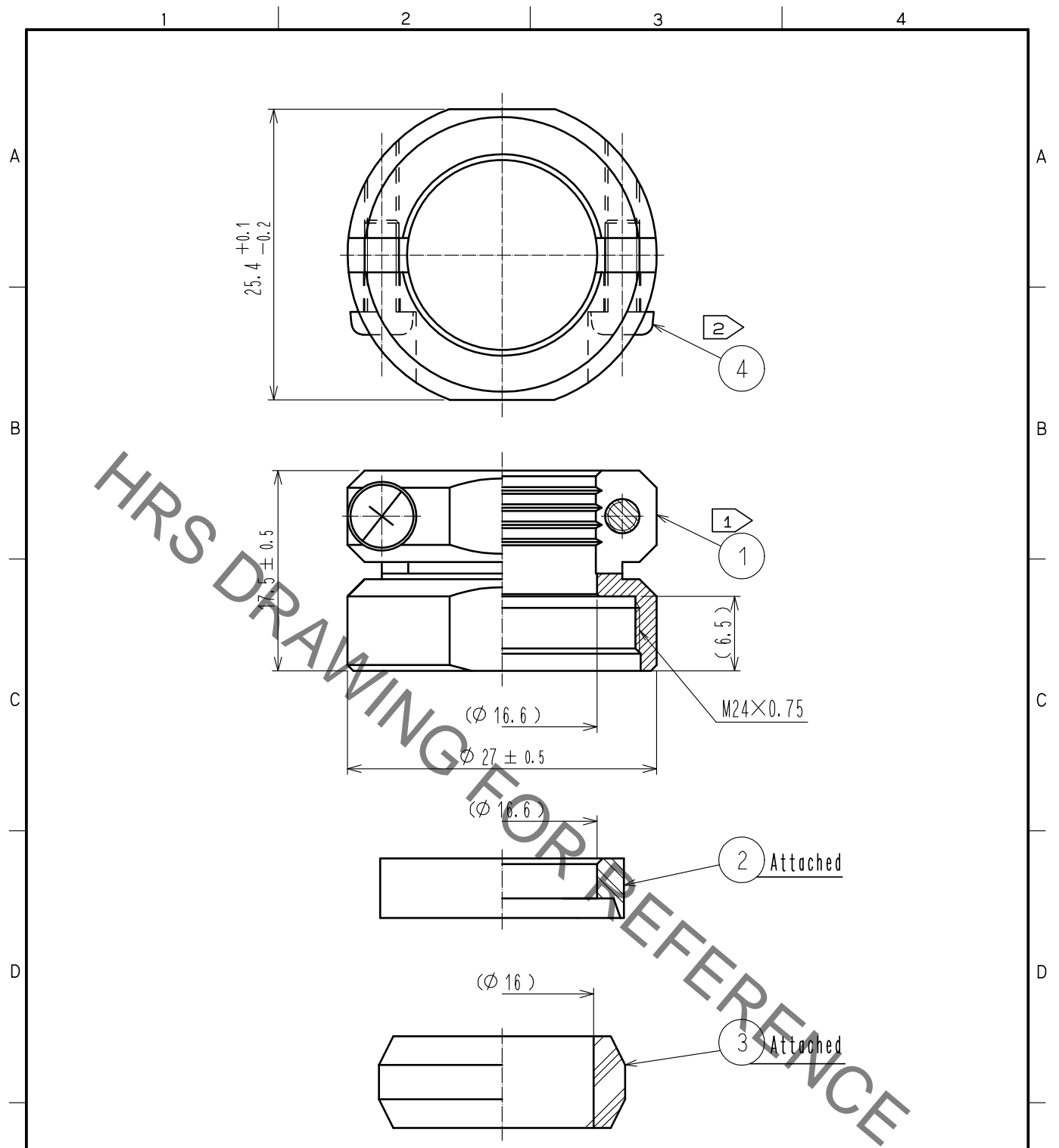

- Notes
- ① The recommended clamp torque of ref. No. ① : 4 to 4.5 N·m .
 LOCTITE 263, HENKEL JAPAN or equevalent is recommended to prevent ref. No. ① from loosening.
 - ② The recommended clamp torque of ref. No. ④ to be 0.65 to 0.7 N·m .
 - 3. The cable pull and twisting strength, waterproof tightness and other characteristics may differ, depending on the cable structure. Please confirm before the use.

2	PPS	(Black) UL94V-0	4	Stainless steel	M3×0.5×8		
1	Brass	Black chrome plating	3	Acrylonitrile butadiene rubber	(Grey)		
NO.	MATERIAL	FINISH . REMARKS	NO.	MATERIAL	FINISH . REMARKS		
UNITS mm		SCALE 2 : 1	COUNT 	DESCRIPTION OF REVISIONS	DESIGNED	CHECKED	DATE
HIROSE ELECTRIC CO., LTD.	APPROVED	·HY. KOBAYASHI	18.02.26	DRAWING NO.	EDC-110478-31-00		
	CHECKED	·HY. KOBAYASHI	18.02.26	PART NO.	JR21WCC-16(31)		
	DESIGNED	·TH. KAMEYA	18.02.23	CODE NO.	CL114-2062-0-31		
	DRAWN	·MK. INOUE	18.02.14		1/1		