

Sep.1.2021 Copyright 2021 HIROSE ELECTRIC CO., LTD. All Rights Reserved.  
In case of consideration for using Automotive equipment / device which demand high reliability, kindly contact our sales window correspondents.

Fig.2(1:1)

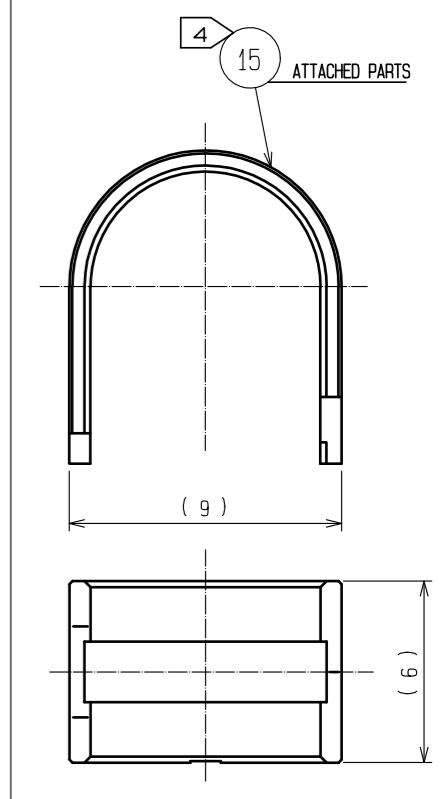
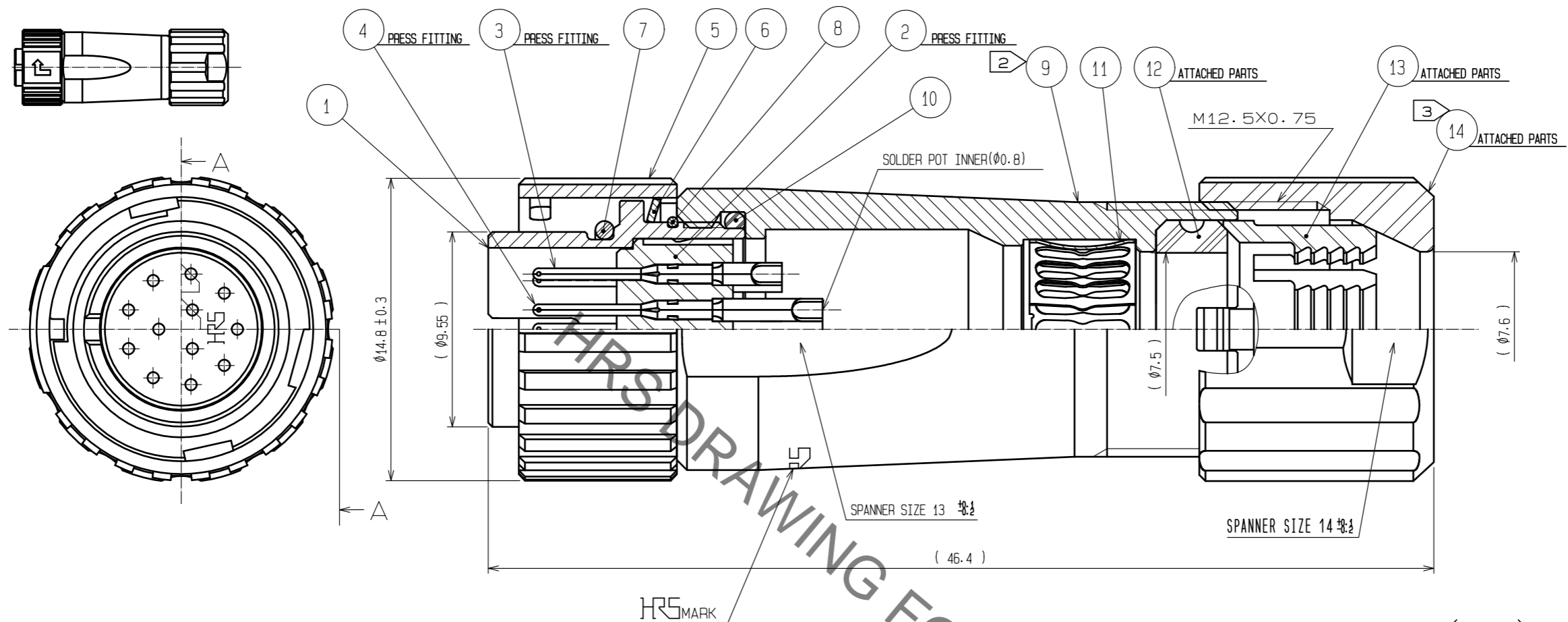
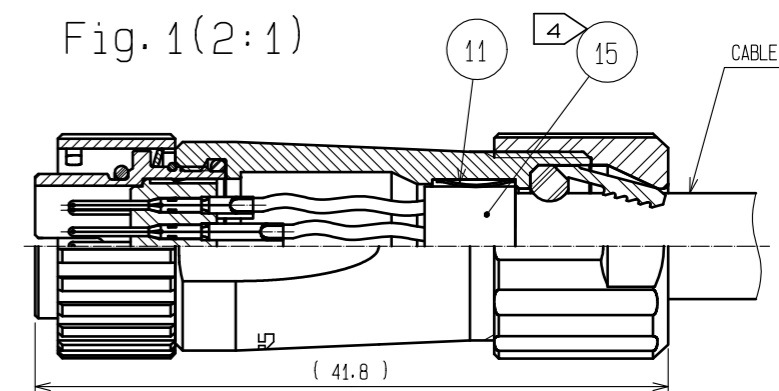

Fig.1(2:1)



- NOTES
- 1 PLATING(REF. NO. ③, ④)  
CONTACT AREA : GOLD 0.2μm min  
OTHERS : GOLD AND NICKEL  
UNDER PLATING : NICKEL 2μm min
  - 2 THE RECOMMENDED CLAMP TORQUE OF REF.NO. ⑨ TO BE 1 TO 1.5N·m.  
THREAD LOCKER TO THE THREADED PORTION OF REF.NO. ① IS RECOMMENDED TO PREVENT REF.NO. ⑨ FROM LOOSING.  
RECOMMENDED THREAD LOCKER : LOCTITE 263, HENKEL JAPAN LTD.
  - 3 THE RECOMMENDED CLAMP TORQUE OF REF.NO. ⑭ TO BE 0.8 TO 1N·m.  
THREAD LOCKER AND LOCK PRIMER TO THE THREADED PORTION M12.5X0.75 OF REF.NO. ⑨ IS RECOMMENDED TO PREVENT REF.NO. ⑭ FROM LOOSING.  
RECOMMENDED THREAD LOCKER AND LOCK PRIMER : LOCTITE 263, LOCK PRIMER 7649, HENKEL JAPAN LTD.
  - 4 FASTEN REF.NO. ⑮ TO THE CABLE WITH THE CABLE CRIMPING TOOL.  
AND MAKE REF.NO. ⑮ CONTACT WITH REF.NO. ⑪ (REFER TO Fig.1).  
REFER TO THE TECHNICAL SPECIFICATION ETAD-C0099 FOR DETAILS.  
APPLICABLE CABLE CRIMPING TOOL : LF-TC-01 (CL150-0234-6)
  - 5 APPLICABLE CABLE ASSEMBLY FIXTURE : LF10BP-T01 (CL150-0235-9)  
CABLE ASSEMBLY FIXTURE IS USED AS A RECEPTACLE STAND OF EXTRACT AND THE PART NUMBER ① OF AN ASSEMBLY.
  - 6 Fig.2 SHOWS THE APPEARANCE AFTER ASSEMBLY.
  - 7 ROTATION EXAMPLES OF REF. NOS. ⑤, ⑨ AND ⑭ TO ① ARE SHOWN.
  - 8 CABLE PULL FORCE, TWISTING STRENGTH, WATER TIGHTNESS AND OTHER CHARACTERISTICS MAY DIFFER DEPENDING ON CABLE SPECIFICATIONS AND STRUCTURE.  
PLEASE EVALUATE UNDER THE ACTUAL CONDITIONS PRIOR TO USE.

NO.	MATERIAL	FINISH . REMARKS	NO.	MATERIAL	FINISH . REMARKS
8	STAINLESS STEEL		15	BRASS	NICKEL PLATING
7	CHLOROPRENE RUBBER	(BLACK)	14	PPS	(NATURAL, BROWN) UL94V-0
6	STAINLESS STEEL		13	POLYAMIDE	(NATURAL, MILKY WHITE) UL94V-0
5	ZINC ALLOY	NICKEL PLATING	12	CHLOROPRENE RUBBER	(BLACK)
4	COPPER ALLOY	①	11	PHOSPHOR BRONZE	NICKEL PLATING
3	COPPER ALLOY	①	10	CHLOROPRENE RUBBER	(BLACK)
2	PPS	(BLACK) UL94V-0	9	ZINC ALLOY	NICKEL PLATING
1	ZINC ALLOY	NICKEL PLATING			

UNITS	SCALE	COUNT	DESCRIPTION OF REVISIONS	DESIGNED	CHECKED	DATE
mm	4 : 1	△				
APPROVED : HY. KOBAYASHI			18.02.21	DRAWING NO. EDC-114243-31-00		
CHECKED : HY. KOBAYASHI			18.02.21	PART NO. LF10WBP-12P(31)		
DESIGNED : TY. SUZUKI			18.02.21	CODE NO. CL136-0008-0-31		
DRAWN : HM. SAITO			18.02.16	1/1		