

MS-190 Series

DC to 11GHz, 0.68mm Height, Ultra Compact Coaxial Switch Connector

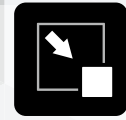

Coax Switch



Compact



RF

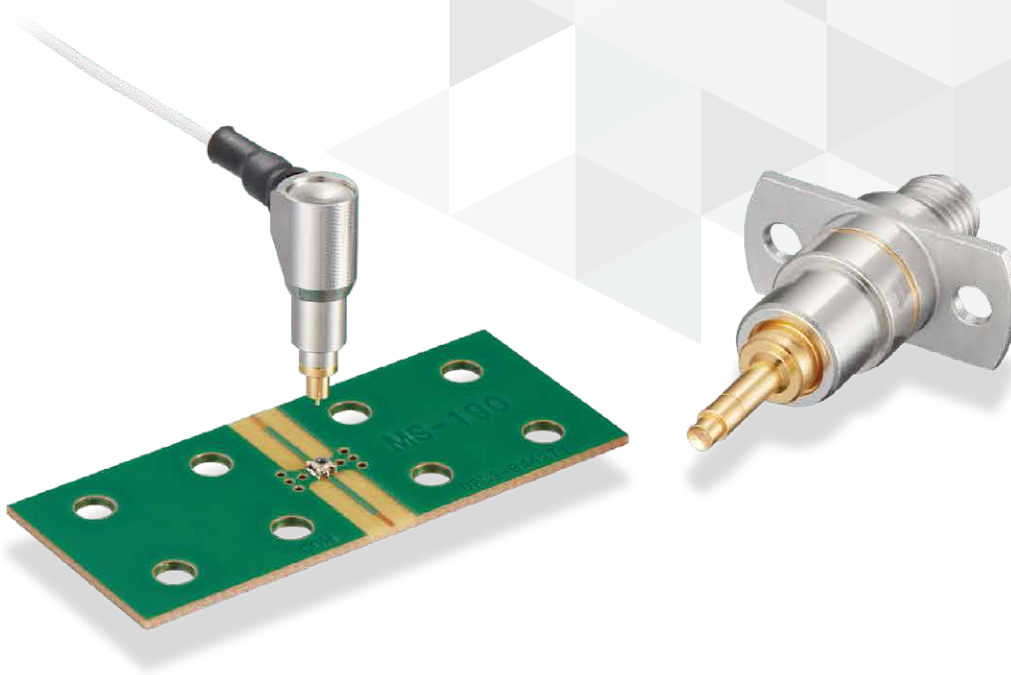

Overview

The MS-190 Series is an ultra compact coaxial switch connector, developed for inspecting RF module functionality and high frequency circuits.

The MS-190 Series supports high frequency up to 11GHz for high density board mounting in compact communication terminals such as smartphones and wearable devices.

It allows secure and easy circuit inspection.

Features

1. Wide Frequency Range

Wide frequency range from DC to 11GHz (when not mated).

2. Low Insertion Loss

When Unmated:
 DC-3GHz 0.1dB Max.
 3-6GHz 0.2dB Max.
 6-11GHz 0.3dB Max.

3. Space-saving, Low Profile

Height Above Board: 0.68mm
 Size: 1.45mmx1.45mm (nominal)
 Weight: 0.003g

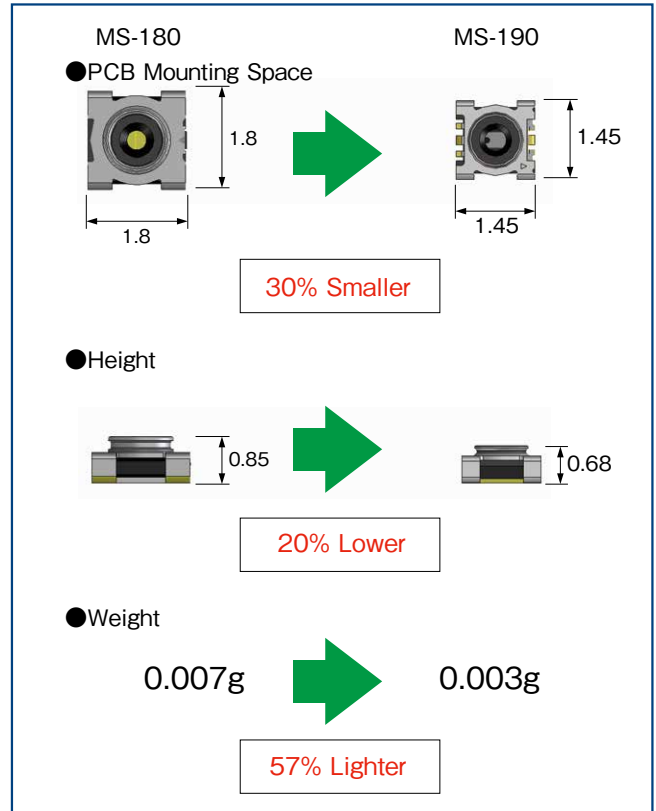

Compared to HRS's existing MS-180 products.

4. High Contact Reliability

Independent 2-point contact ensures high contact reliability.

5. Overmolding Technology Prevents Dust Intrusion and Flux Wicking

The overmold design prevents gaps between the contact and housing which may result in dust intrusion and flux wicking.

6. Pick & Place Mounting

Packaged on tape-and-reel for automated mounting.

7. Beryllium Free, Halogen Free

All materials and substances used to produce this receptacle comply with Halogen and Beryllium free standards.

*Definition according to IEC 61249-2-21.

Br 900 ppm Max., Cl 900 ppm Max., and Br + Cl 1500 ppm Max.

Product Specifications

Operating Temperature	-40 to +85°C			
Rated Power	2W			
Frequency Range	DC to 11GHz Not Mated with Probe		DC to 6GHz Mated with Probe (MS-190-HRMJ-F6)	
V.S.W.R.	DC to 3.0GHz	1.2 Max.	DC to 3.0GHz	1.3 Max.
	3.0 to 6.0GHz	1.3 Max.	3.0 to 8.0GHz	1.7 Max.
	6.0 to 11.0GHz	1.4 Max.		
Insertion Loss	DC to 3.0GHz	0.1dB Max.	DC to 3.0GHz	0.5dB Max.
	3.0 to 6.0GHz	0.2dB Max.	3.0 to 6.0GHz	0.7dB Max.
	6.0 to 11.0GHz	0.3dB Max.		
Isolation	DC to 3.0GHz	25dB Min.		
	3.0 to 6.0GHz	20dB Min.		
	6.0 to 11.0GHz	12dB Min.		

Item	Specifications	Conditions
Contact Resistance	100m Ω Max.	100mA Max.
Insulation Resistance	1000M Ω Min.	100V DC
Withstanding Voltage	No flashover or insulation breakdown	100V AC for 1 min.
Vibration Resistance	No electrical discontinuity of 1 μ s or more	Frequency : 10 to 55Hz, single amplitude of 0.75mm, 10 cycles in each of the 3 axis
Shock Resistance	No electrical discontinuity of 1 μ s or more	Acceleration of 490m/s ² , 11ms duration, sine halfwave, 3 cycles in each of the 3 axis.
Temperature Cycle	Contact Resistance : 100m Ω Max. Insulation Resistance : 10M Ω Min.	Temperature : -55 → +15 to +35 → +85 → +15 to +35°C Time : 30 → 2 to 3 → 30 → 2 to 3 minutes 100 cycles
Heat Resistance	Contact Resistance : 100m Ω Max. Insulation Resistance : 10M Ω Min.	96 hours at 85°C
Cold Resistance	Contact Resistance : 100m Ω Max. Insulation Resistance : 10M Ω Min.	96 hours at -55°C
Humidity Resistance (Steady State)	Contact Resistance : 100m Ω Max. Insulation Resistance : 10M Ω Min.	96 hours at 40 ± 2°C and humidity of 90 to 95%
Mating Durability	Contact Resistance : 100m Ω Max.	100 cycles

Materials / Finish

Part	Materials	Finish	Remarks
Shell	Phosphor Bronze	Partially Gold Plated	-
Insulator	LCP	-	UL94V-0
Common Contact	Copper Alloy	Partially Gold Plated	-
Antenna Contact	Copper Alloy	Partially Gold Plated	-

High Frequency Performance (Typical)

● Normally Closed (Not Mated with Probe)

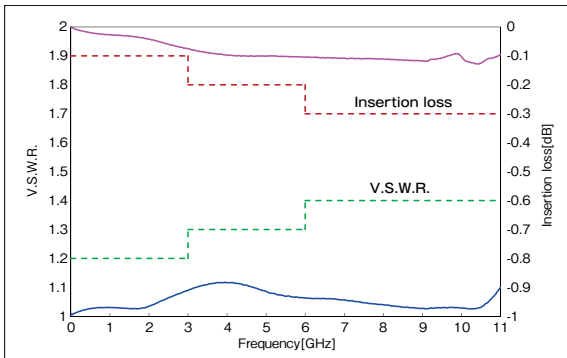

● Normally Open (Mated with Probe)

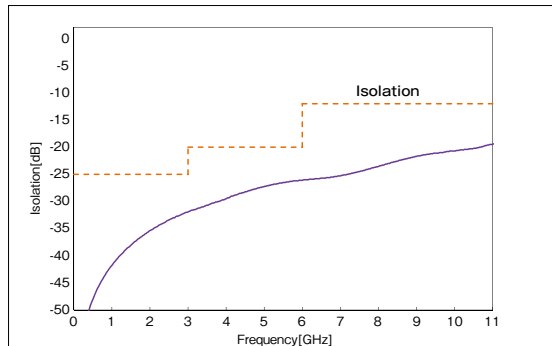
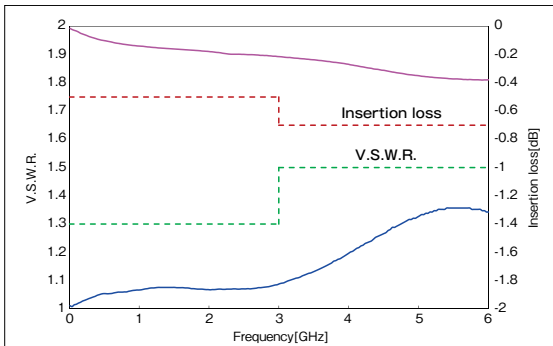

Receptacle

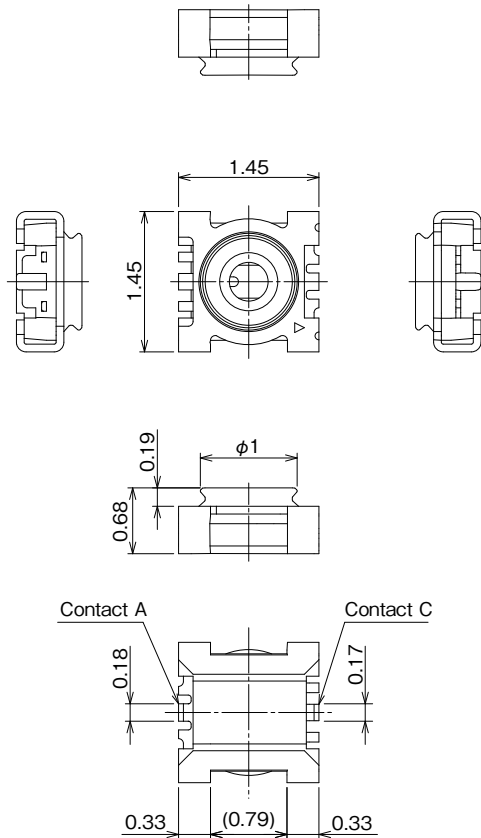
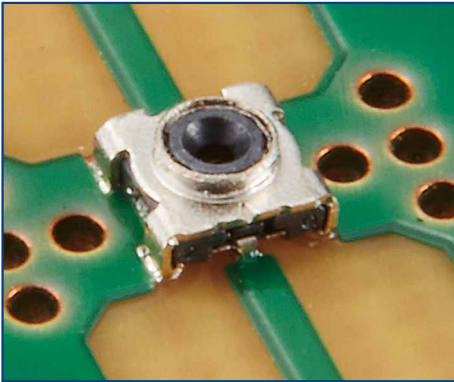

■ Circuit Diagram

Normally Closed (N.C.)

Normally Open (N.O.)

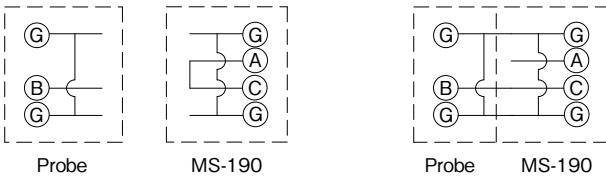

■ Specified Land Pattern and Metal Mask Dimensions

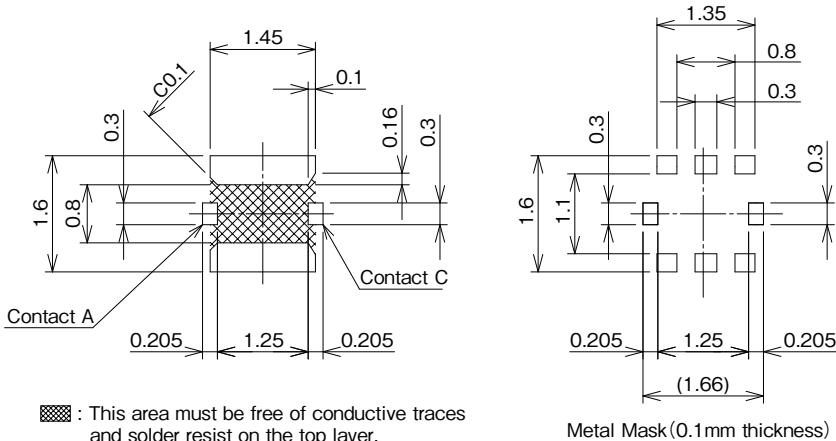

Note 1 : Do not reflow the product using a land pattern or metal mask dimensions other than those specified. Doing so may cause solder and/or flux wicking affecting the product performance.

Note 2 : Do not manual solder when mounting MS-190, as it could result in solder and flux wicking to the contact areas.

Part No.	HRS No.	Pachase Unit
MS-190	CL0358-0354-5-00	20,000pcs per reel

Packaging Specifications

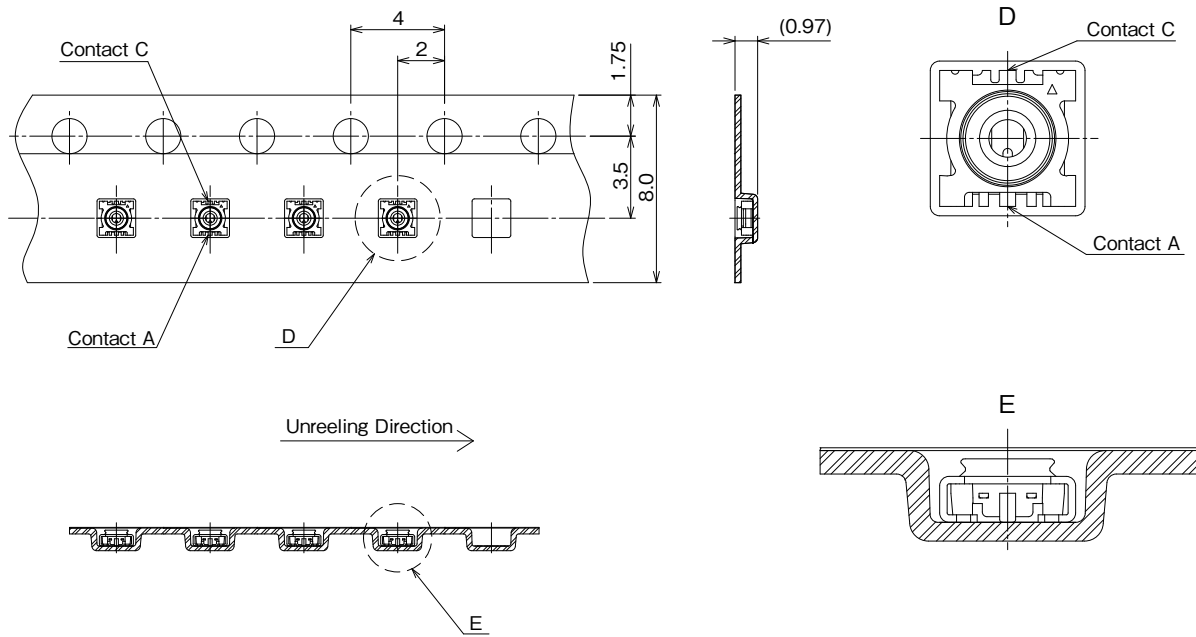

● Reel Dimensions

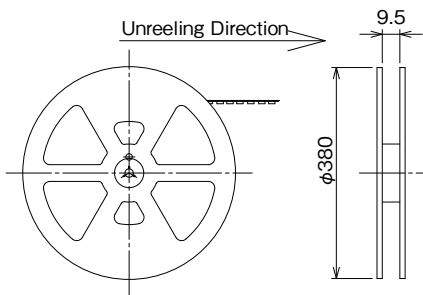

Recommended Temperature Profile

● Using Lead-free Solder Paste

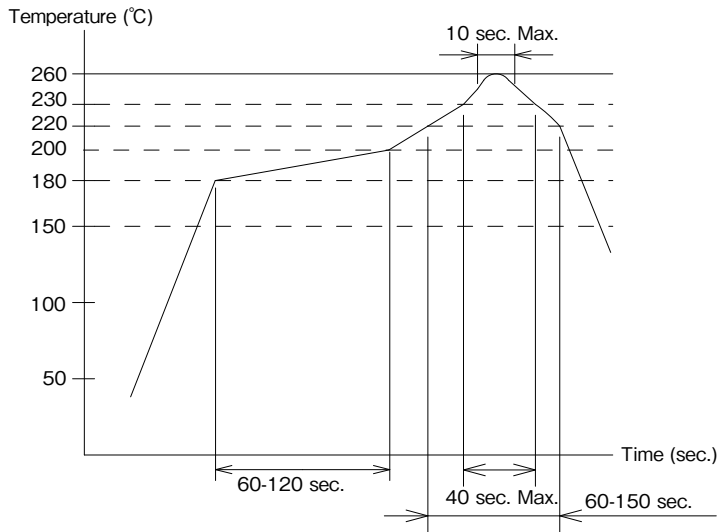

[Conditions]

Maximum Temperature : 260°C
Peak Temperature Time : 10 sec. Max.
230°C Min. : 40 sec. Max.
220°C Min. : 60-150 sec.
180 to 200°C : 60-120 sec.

Metal Mask Thickness : 0.1mm
Reflow Cycles : 2 cycles

Measurement / Inspection Probe

■ Fixed Flange with Floated Probing Tip (for Mass Production Lines)

● SMA Conversion Adapter

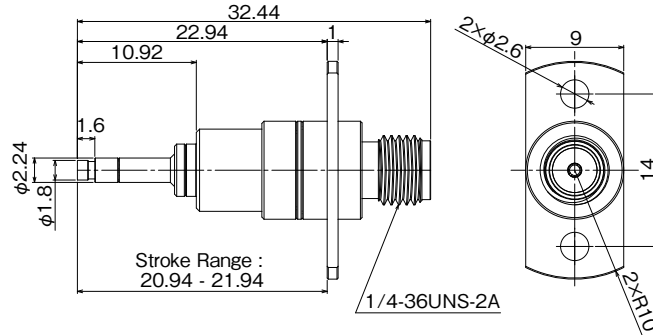

Part No.	HRS No.	Mating Durability	Purchase Unit
MS-190-HRMJ-F6	CL0358-0007-0-00	1 million cycles	1pc per bag

Note 1 : The probe should mate vertically with the receptacle.
Always use the probe within the specified stroke length.

Note 2 : This mating durability only applies to this specific probe.

■ Probe with Friction Lock (For Testing)

● MS-190-040LP-H1

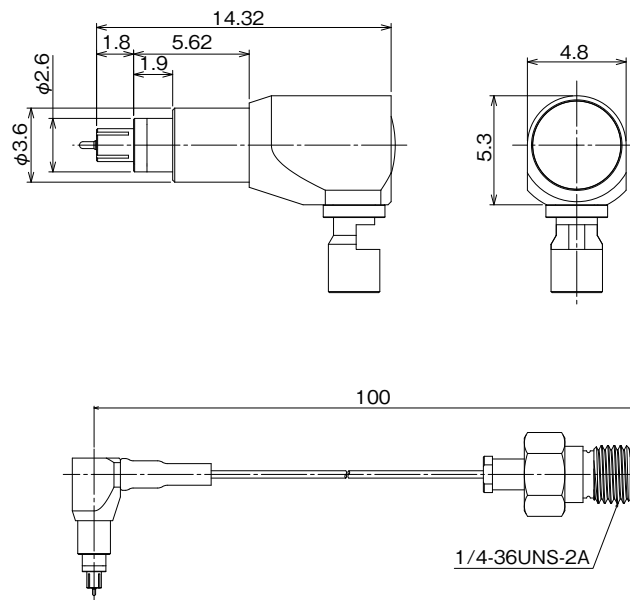

Part No.	HRS No.	Mating Durability	Purchase Unit
MS190LH1-HRMJ-040V100	CL0358-0016-0-01	500 cycles	1pc per bag

Note 1 : This probe has a friction lock mechanism to keep the probe connected with the receptacle without foreign assistance. However, avoid pulling on the cable and make sure the probe is vertical to the receptacle before use.

Note 2 : This mating durability only applies to this specific probe.

Note 3 : Please order using the above Part No. as it will be delivered as a complete assembly (probe with cable). Please contact a Hirose Sales Representative for customization of cable lengths and the attached connector.

Precautions

1. This product cannot be washed.
2. During design, make sure that the product will not be subjected to force from the panel when dropped while mounted to the board.
3. This product is intended to be used for circuit inspection only.
4. Do not use the friction lock probe for mass production lines.
5. Do not perform manual solder for mounting of MS-190, since it could result in solder and flux wicking to the contact areas.
6. When using a heat gun, hot plate, or similar methods for mounting the receptacle on, please keep use within 10 seconds at 260°C or less. If usage exceeds the above conditions, the plastic may melt and deform.
7. Refrain from using land patterns or metal mask dimensions other than those specified by Hirose as it may result in solder flux and wicking causing product failure.
8. Refrain from using this product in environments of dust, high humidity, gas, and extremely high and low temperatures outside of the range listed in the specification sheet.
9. When cutting the PCB after mounting MS-190 with a router, etc., design the bridge to be away further away from MS-190. Suck up shavings in order to prevent contact failure resulting from debris entering the contact portion of the connector.

While Taking into Consideration

Specifications mentioned in this catalog are reference values.

When considering to order or use this product, please confirm the Drawing and Product Specifications sheets.

Use an appropriate cable when using the connector in combination with cables.

If considering usage of a non-specified cable, please contact your sales representative.

If assembly process is done by jigs & tools which are not identified by Hirose, assurance will not be given.

If considering usage for below mentioned applications, please contact your sales representative.

In cases where the application will demand a high level of reliability, such as automotive, medical instruments, public infrastructure, aerospace/ defense etc. Hirose must review before assurance of reliability can be given.