

TF20 Series



Compact Size and Easy Mounting

Product : TF20-15S-0.175SHW

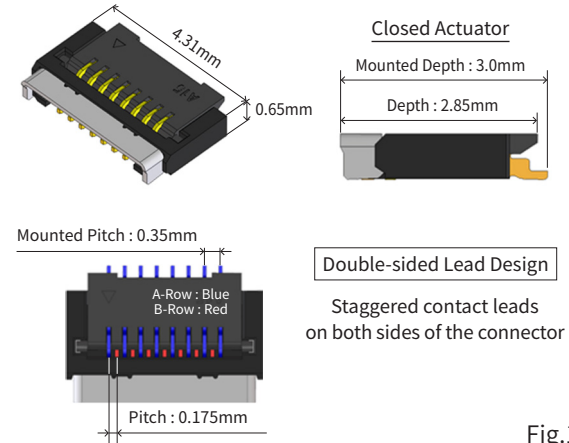

Fig.1

■ Features

1. Narrow Pitch, Low Height and Space-saving

Compact size with 0.175mm pitch, 0.65mm height, and 3.0mm mounted depth contribute to high density mounting.

Meanwhile, double-sided lead design provides a 0.35mm mounted pitch and ensures easier mounting. (Fig. 1)

2. High FPC Retention Force & Reliability

FPC side catch design secures connection and enhances reliability. (Fig. 2)

3. Achieve Both Space Reduction and High Durability

Metal shell with retention tabs covers the mating face and achieve high durability against external forces. (Fig. 3)

4. Back Flip / Front Axis™

Secures a constant contact gap regardless of actuator operation. The actuator can be closed before FPC is inserted.

Furthermore, since the actuator can be delivered and mounted in a closed state, workability during inspection and storage after mounting is enhanced.

5. Pick & Place Mounting

Offered in tape and reel packaging that is compatible with automatic machine mounting.

6. Halogen-Free

All materials and substances used to produce this product comply with Halogen-Free standards.

*As defined by IEC 61249-2-21

Br : 900ppm max., Cl : 900ppm max.,

Br+Cl : 1,500ppm max.

FPC Side Catch Design

Two Protrusions of Actuator and Housing Secure FPC Tab from Upper and Lower Sides

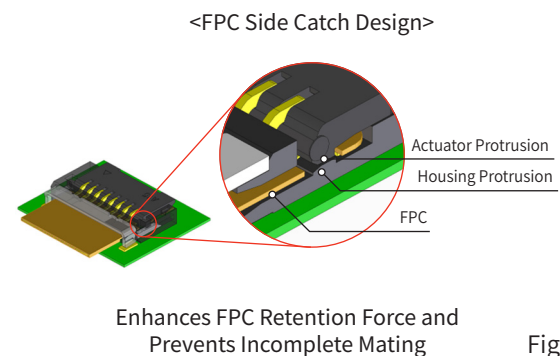

Fig.2

High Durability Against External Forces

Metal Shell Integrated with Retention Tabs Covers Mating Face

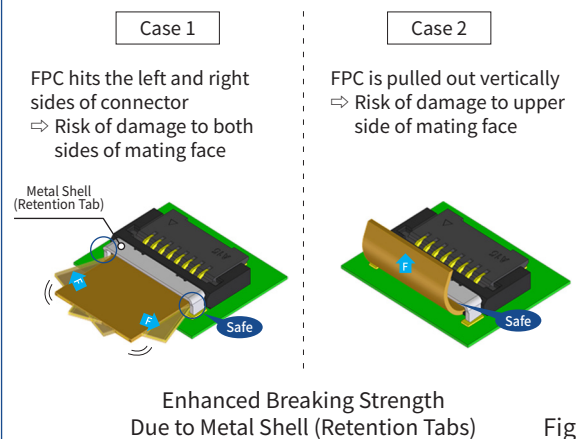

Fig.3

Product Specifications

Ratings	Rated Current : 0.15A (Note 1)	Operating Temperature : -55 to +85 °C (Note 2)	Storage Temperature : -10 to +50 °C (Note 3)
	Rated Voltage : 30V AC/DC	Operating Humidity Range : Relative humidity 90% Max. (No condensation)	Storage Humidity Range : Relative humidity 90% Max. (No condensation)

Adaptive FPC Contact Specifications	Thickness : 0.12±0.02mm Gold plated Contact Traces
-------------------------------------	--

Items	Specifications	Conditions
1. Contact Resistance	300mΩ Max. Includes FPC conductor resistance	1mA
2. Insulation Resistance	50MΩ Min.	100V DC
3. Withstanding Voltage	No flashover or insulation breakdown	90V AC for 1 min.
4. Mating Durability (Insertion/withdrawal)	Contact resistance : 300mΩ Max. No damage, cracks, or parts dislocation.	10 cycles
5. Vibration	No electrical discontinuity for more than 1μs. Contact resistance : 300mΩ Max. No damage, cracks, or parts dislocation	Frequency : 10 to 55Hz, Total Amplitude 1.5mm for 2hours in 3 axis directions
6. Shock Resistance	No electrical discontinuity of 1μs or more Contact resistance : 300mΩ Max. No damage, cracks, or parts dislocation.	Acceleration : 981m/s ² , 6ms duration, Sine half-waveform, 3 cycles in each of the 3 axis.
7. Humidity (Steady State)	Contact resistance : 300mΩ Max. Insulation resistance : 50MΩ Min. No damage, cracks, or parts dislocation	96 hours at 40°C and humidity of 90% to 95%
8. Temperature Cycle	Contact resistance : 300mΩ Max. Insulation resistance : 50MΩ Min. No damage, cracks, or parts dislocation	Temperature : -55 → +15 to +35 → +85 → +15 to +35 °C Time : 30 → 2 to 3 → 30 → 2 to 3 min. 5 cycles
9. Soldering Heat Resistance	No deformation of components affecting performance No abnormality in electrical performance	Reflow : At the recommended temperature profile

Note 1 : When passing the current through all of the contacts, use 70% of the current rating.

Note 2 : Includes temperature rise caused by current flow.

Note 3 : The term “storage” refers to products stored for long period of time prior to mounting and use.

Operating temperature range and humidity range cover non-conducting condition of installed connectors in storage, shipment or during transportation.

Material / Finish

Part	Material	Finish	Remarks
Insulator	LCP	Black	UL94V-0
Actuator	PA9T	Black	
Contact	Phosphor Bronze	Partially Gold Plated	—
Retention Tab	Phosphor Bronze	Tin Plated	

Product Number Structure

Refer to the chart below when determining the product specifications from the product number.
Please select from the product numbers listed in this catalog when placing orders.

TF 20 - 15S - 0.175 SHW (800)

① ② ③ ④ ⑤ ⑥

① Series Name : TF	④ Contact Pitch : 0.175mm
② Series No. : 20	⑤ Terminal Type SHW : SMT Horizontal Staggered Array Mounting Type
③ No. of Pos. : 15pos.	⑥ Specifications (800) : Standard, Emboss tape packaging (5,000pcs per reel)

Connector Dimensions

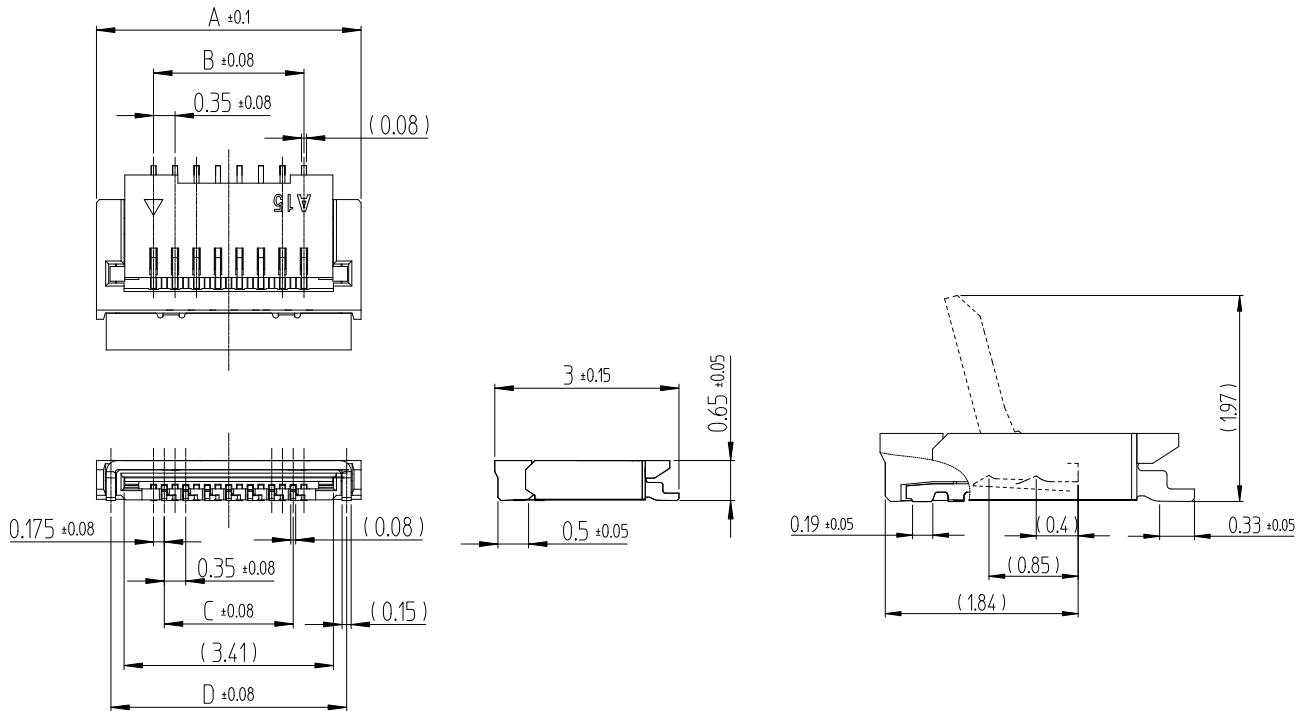

Note 1 : The coplanarity of each terminal lead is within 0.1mm.

Note 2 : This product is packaged and sold in tape and reel. Check the packaging specifications for details.

Note 3 : Sink mark reliefs may be added due to improvements.

Note 4 : Black spots may appear on the mold resin, but this does not affect product performance.

Additionally, the terminal plating may change color after reflow, however this does not represent a quality issue.

Unit : mm

Part No.	HRS No.	No. of Pos.	A	B	C	D	Purchase Unit
TF20-9S-0.175SHW(800)	Under Planning	9	3.260	1.40	1.05	2.790	5,000pcs per reel
TF20-10S-0.175SHW(800)	Under Planning	10	3.435	1.40	1.40	2.965	
TF20-15S-0.175SHW(800)	CL0480-0801-0-00	15	4.310	2.45	2.10	3.840	
TF20-16S-0.175SHW(800)	Under Planning	16	4.485	2.45	2.45	4.015	
TF20-17S-0.175SHW(800)	Under Planning	17	4.660	2.80	2.45	4.190	
TF20-20S-0.175SHW(800)	Under Planning	20	5.185	3.15	3.15	4.715	

Note 5 : Contact positions without HRS No. are currently under planning.

Please contact Hirose for detailed information about product variations.

◆ Recommended Land / Metal Mask Dimensions

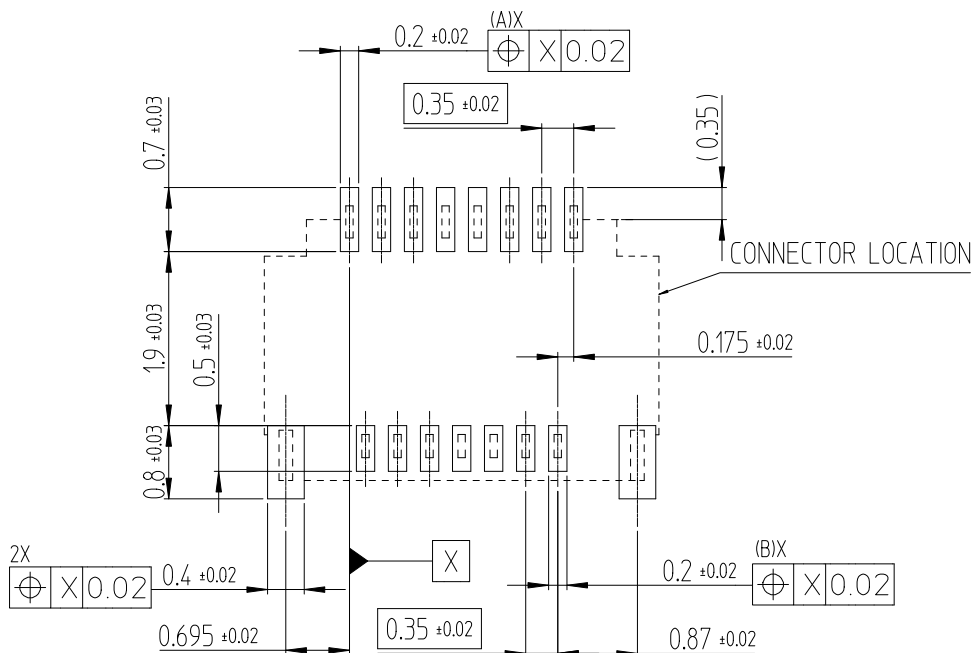

Recommended Metal Mask Thickness: 0.1mm

Unit : mm

Part No.	HRS No.	No. of Pos.	A	B
TF20-9S-0.175SHW(800)	Under Planning	9	5.0	4.0
TF20-10S-0.175SHW(800)	Under Planning	10	5.0	5.0
TF20-15S-0.175SHW(800)	CL0480-0801-0-00	15	8.0	7.0
TF20-16S-0.175SHW(800)	Under Planning	16	8.0	8.0
TF20-17S-0.175SHW(800)	Under Planning	17	9.0	8.0
TF20-20S-0.175SHW(800)	Under Planning	20	10.0	10.0

Note 1 : Contact positions without HRS No. are currently under planning.
Please contact Hirose for detailed information about product variations.

◆ Recommended FPC Dimensions

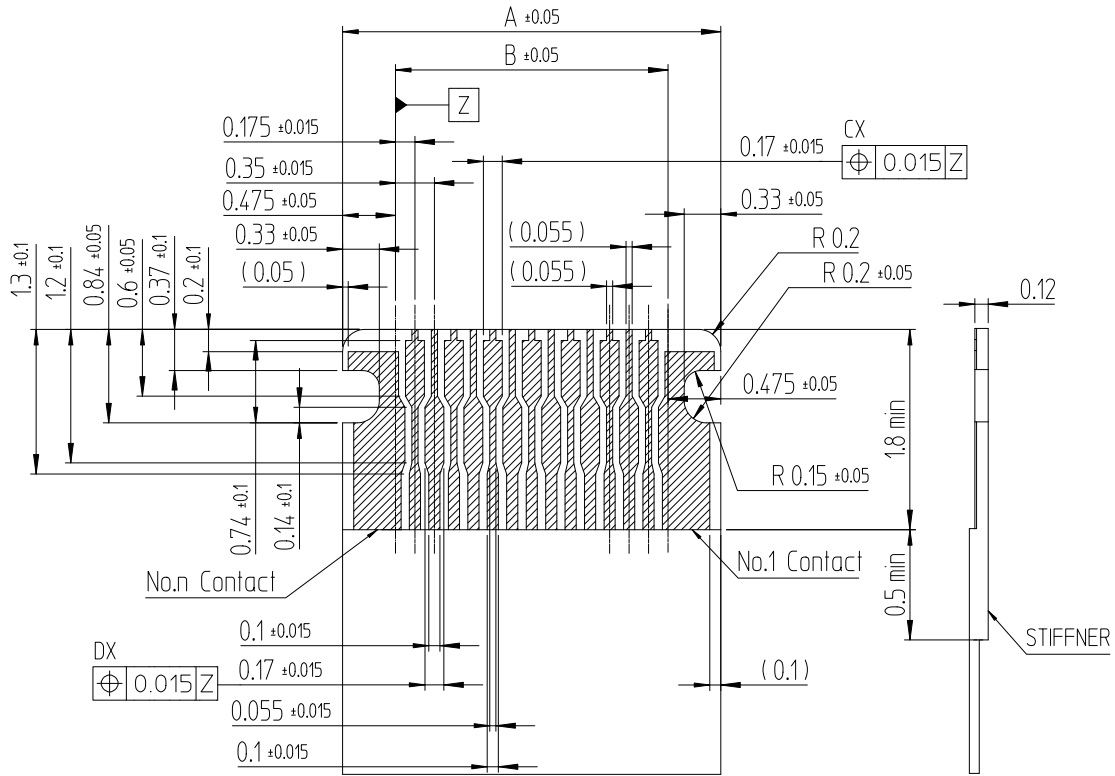

Unit : mm

Part No.	HRS No.	No. of Pos.	A	B	C	D
TF20-9S-0.175SHW(800)	Under Planning	9	2.350	1.400	4	5
TF20-10S-0.175SHW(800)	Under Planning	10	2.525	1.575	5	5
TF20-15S-0.175SHW(800)	CL0480-0801-0-00	15	3.400	2.450	7	8
TF20-16S-0.175SHW(800)	Under Planning	16	3.575	2.625	8	8
TF20-17S-0.175SHW(800)	Under Planning	17	3.750	2.800	8	9
TF20-20S-0.175SHW(800)	Under Planning	20	4.275	3.325	10	10

Note 1 : Contact positions without HRS No. are currently under planning.
Please contact Hirose for detailed information about product variations.

◆ FPC Construction (Recommended Specifications)

● FPC : Flexible Printed Circuit

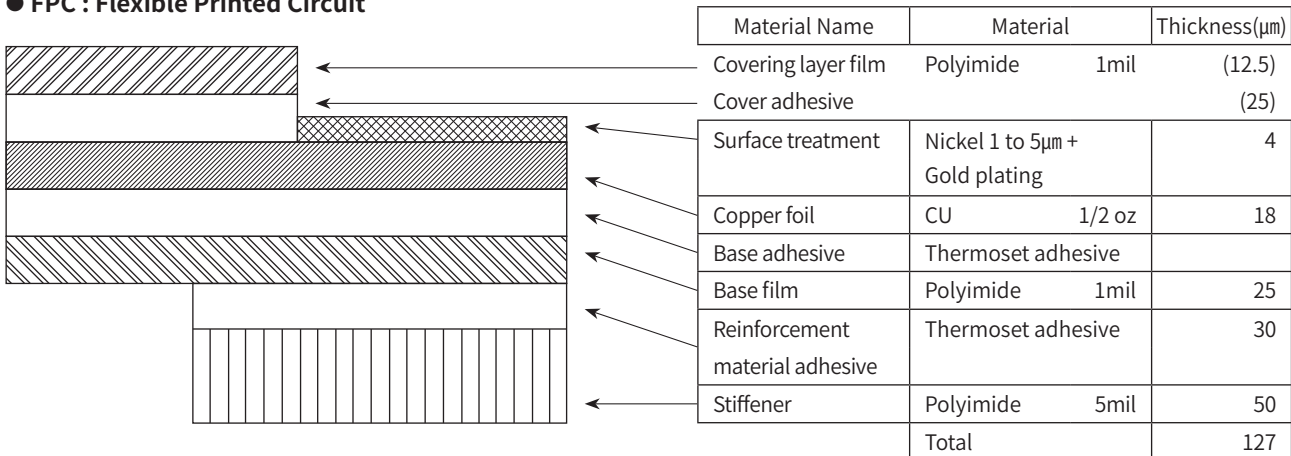

NOTE 1 : The material composition of FPC is for reference. Please make the thickness of the FPC mating section 0.12 ± 0.02 mm in reference to the above FPC construction.

NOTE 2 : For details about component configuration, please contact a FPC manufacturer.

◆ Packaging Specifications

● Embossed Carrier Tape Dimensions

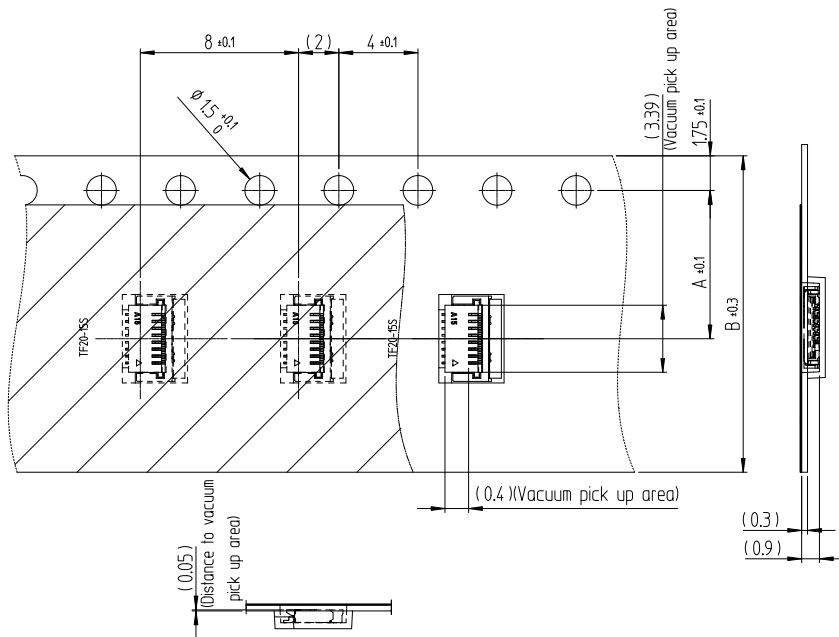

● Reel Dimensions

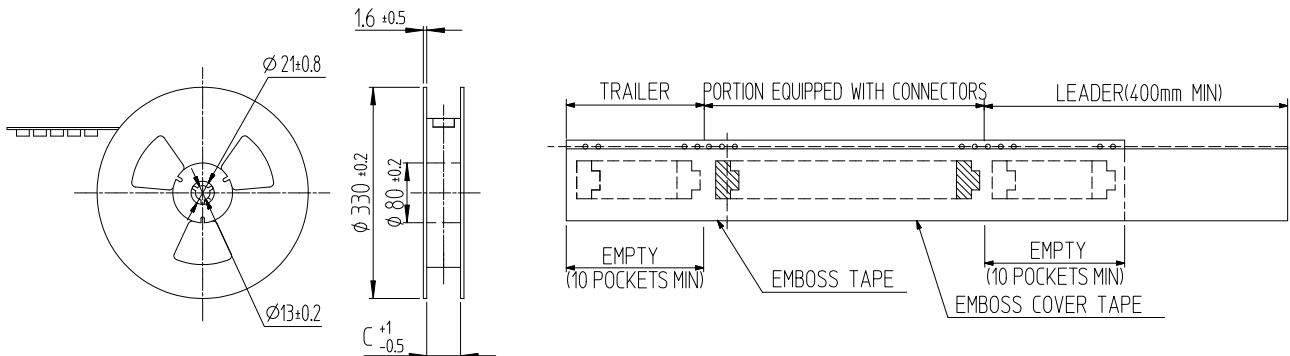

Note 1 : 5,000pcs / Reel (Outer diameter of Reel φ330mm)

Note 2 : Material

- 1) Emboss tape : PS (Antistatic Treatment)
- 2) Cover tape : PET (Antistatic Treatment)

Unit : mm

Part No.	HRS No.	No. of Pos.	A	B	C
TF20-9S-0.175SHW(800)	Under Planning	9	7.5	16.0	16.5
TF20-10S-0.175SHW(800)	Under Planning	10	7.5	16.0	16.5
TF20-15S-0.175SHW(800)	CL0480-0801-0-00	15	7.5	16.0	16.5
TF20-16S-0.175SHW(800)	Under Planning	16	7.5	16.0	16.5
TF20-17S-0.175SHW(800)	Under Planning	17	7.5	16.0	16.5
TF20-20S-0.175SHW(800)	Under Planning	20	7.5	16.0	16.5

Note 3 : Contact positions without HRS No. are currently under planning.

Please contact Hirose for detailed information about product variations.

◆ Recommended Temperature Profile

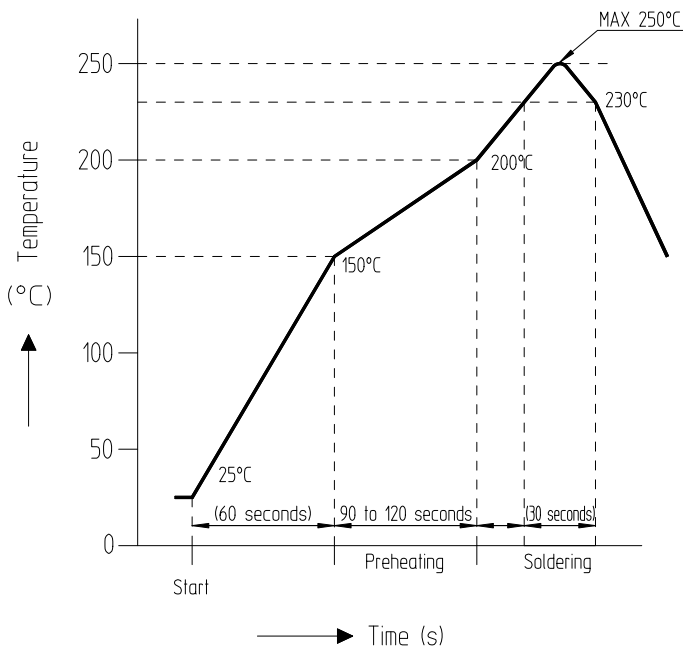

HRS Test Conditions

Reflow Method : Reflow, IR/hot air
 Reflow Environment : Room air
 Solder Composition : Paste, 96.5%Sn/3%Ag/0.5%Cu
 (M705-221CM5-32-10.5 from Senju Metal Industry Co., Ltd.)

Test Board : Glass epoxy 50mm×25mm×1mm thick
 Land Dimensions : Check the recommended land dimensions for details.

Metal Mask : Check the recommended metal mask dimensions for details.

The temperature profile is based on the above conditions. Please check the mounting conditions before use, conditions such as solder paste types, manufacturer, PCB size and any other soldering materials may alter the performance of such materials.

◆ Connector Operation and Precautions

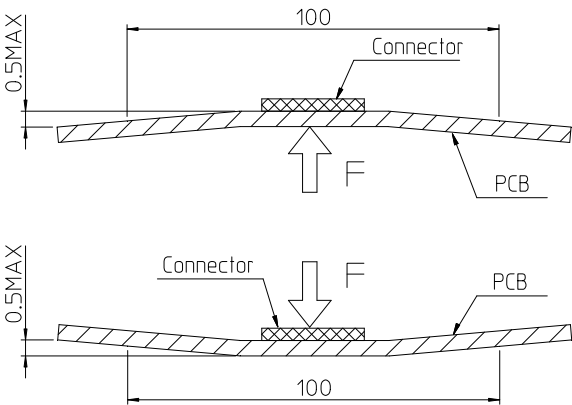
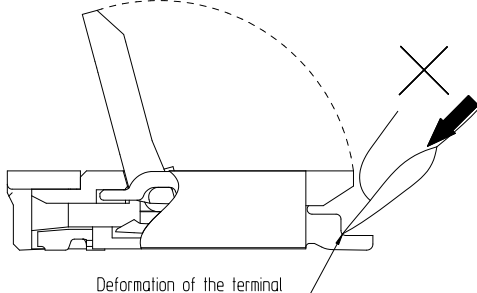
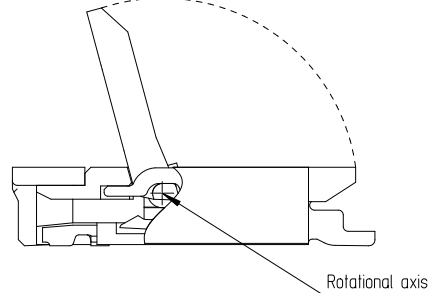
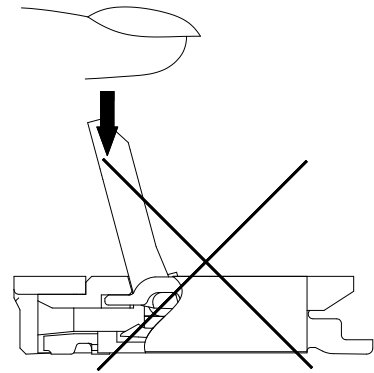
Board Mounting Precautions	FPC Insertion and Mating Precautions
<p>● Board Warpage</p> <p>Be sure to minimize the board warpage as much as possible. The lead co-planarity is 0.1mm or less. Too much board warpage may result in soldering failures or co-planarity issues.</p> <p>● Connector Load</p> <p>Do not apply a force of 0.5N or more to the connector before mounting it on the board in order to prevent connector damage. Do not insert the FPC or operate the connector before mounting.</p> <p>● Board Load</p> <ul style="list-style-type: none"> • Splitting a large board into several pieces • Screwing the board <p>Avoid the handling described above so that no excessive force is exerted on the board during the assembly process. Otherwise, the connector may become defective.</p> <p>● Acceptable Amount of Board Warpage</p> <p>A 100mm wide board has an acceptable warp range of 0.5mm or less. (Below)</p> <p>Excessive amounts of warping will place stress on the connector which may result in damage and malfunction.</p> 	<p>● Actuator Operation</p> <ol style="list-style-type: none"> 1. Do not apply excessive force when releasing the actuator from the initial position (without FPC inserted). Inserting a nail or finger as shown in the below picture may result in terminal deformation.  <p>Deformation of the terminal</p> <ol style="list-style-type: none"> 2. The actuator rotates around the rotational axis as shown below. Please rotate the actuator.  <p>Rotational axis</p> <ol style="list-style-type: none"> 3. Please do not push the actuator downwards with a force of 0.3N force or more as shown below. Otherwise, the actuator may fall off or be damaged. 

Oct. 1. 2021 Copyright 2021 HIROSE ELECTRIC CO., LTD. All Rights Reserved.

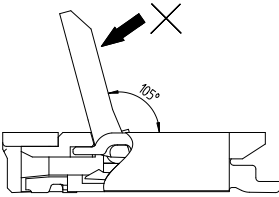
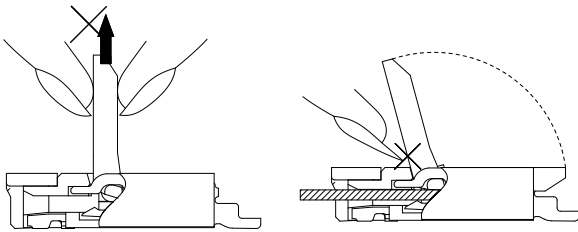
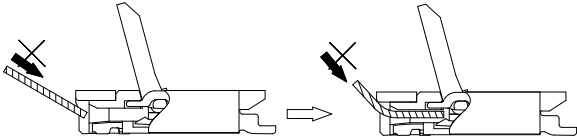
FPC Insertion and Mating Precautions	FPC Insertion and Mating Precautions
<p>4. The actuator is not designed to open more than 105°. Do not apply any force to open it beyond this point. Doing so may result in actuator damage or breakage.</p>  <p>5. Operate the actuator towards the center. It may break if operated on one side of the actuator with FPC inserted.</p> <p>6. Do not pull or pick the actuator to lift it as shown below. Failure to do so may result in connector breakage. (Do not carry out any operation other than rotating the actuator as shown in 2 on the previous page.)</p>  <p>● Contact Orientation</p> <p>This connector utilizes bottom contacts. Insert the FPC with the exposed conductors face down.</p>	<p>● Inserting the FPC</p> <p>1. Insert the FPC horizontally along the surface and at right angle to the connector. Insert it completely to the end. If the FPC is incorrectly inserted at a diagonal the conductors may short-circuit due to pitch shift misalignment or the edge of the FPC may catch in the terminals resulting in deformation of the terminal deformation. This connector has a ZIF structure and its effective mating length is 1.87mm. (when the recommended FPC nominal is used) Use the actuator carefully to prevent the FPC from shifting after insertion.</p> <p>2. Do not insert the FPC diagonally from above. If the FPC is incorrectly inserted at a diagonal as shown in the above FPC insertion process, the FPC may be bent, resulting in pattern breakage or insufficient FPC insertion which may cause conduction failure.</p>  <ul style="list-style-type: none"> • Secure sufficient FPC insertion space during layout design to prevent incorrect FPC insertion. Additionally, if the FPC is too short it will make insertion difficult so please design an appropriate component layout. • Make adjustments with the FPC manufacturer for bending performance and breakage resistance. <p>● Ensuring a Completed Connection</p> <p>After completing the locking operation, check that the actuator is horizontal to the board surface. Do not apply excessive force when the actuator reaches 0°, doing so may damage the terminals. (Allowable force: 1N Max.)</p>

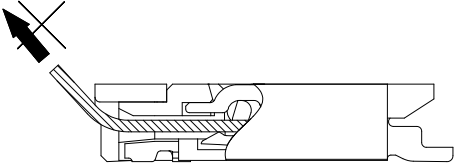
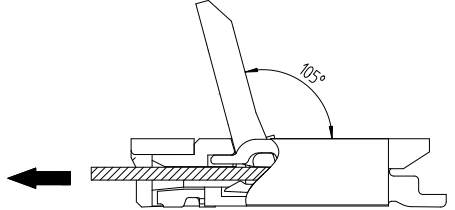
Instructions on FPC Layout after Mating	Other Precautions
<p>● Load to FPC</p> <p>Do not apply direct force to the connector during FPC routing. Contact failure, disconnection or breakage may occur when using a FPC bent near the connector. In general the FPC should not be bent sharply near the insertion opening. Secure the FPC when applying a continuous load.</p> <p style="text-align: center;">Load: $0.25(N) \times n$ MAX (n: number of contacts)</p> 	<p>● Manual Soldering</p> <p>Follow the instructions listed below when soldering the connector manually during repair work, etc.</p> <ol style="list-style-type: none"> 1. Do not perform reflow soldering or manual soldering with the FPC inserted into the connector. 2. Do not overheat the connector. Do not allow the soldering iron to contact any part other than the intended connector leads. Otherwise, the connector may be deformed or melted. 3. Do not use excessive solder (or flux). If excessive solder (or flux) is used on the terminals, solder or flux may adhere to the contacts or the rotating parts of the actuator, resulting in poor contact or a rotation failure of the actuator.
FPC Removal Precautions	
<p>Release the actuator at approximately the center. The actuator may break if operated at one side with the FPC inserted.</p> <p>Remove the FPC with the actuator released.</p> 	

◆ While Taking into Consideration

Specifications mentioned in this catalog are reference values.

When considering to order or use this product, please confirm the Drawing and Product Specifications sheets.

Use an appropriate cable when using the connector in combination with cables.

If considering usage of a non-specified cable, please contact your sales representative.

If assembly process is done by jigs & tools which are not identified by Hirose, assurance will not be given.

If considering usage for below mentioned applications, please contact your sales representative.

In cases where the application will demand a high level of reliability, such as automotive, medical instruments, public infrastructure, aerospace/ defense etc. Hirose must review before assurance of reliability can be given.

HIROSE ELECTRIC CO.,LTD.
2-6-3,Nakagawa Chuoh,Tsuzuki-Ku,Yokohama-Shi 224-8540,JAPAN
<https://www.hirose.com/>
