

UM Series

# Connector for Ultra-fine Coaxial Cable



RF



Wide Variation

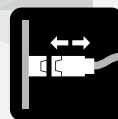

Push On



May. 1. 2024 Copyright 2024 HIROSE ELECTRIC CO., LTD. All Rights Reserved.



# Features

---

## 1. 50Ω Impedance Matching Coaxial Connector

This UM series is a 50Ω impedance matching, push-on-lock coaxial connector.

## 2. Compliance Standard

A highly reliable connector established in the Ministry of Defense Specifications DSP C 6206 (discontinued in 2001).

## 3. Connection Method

The connection method is a crimped connection method that greatly simplifies the process and ensures the connection will work.

## 4. RoHS2 Compliant

## Product Specifications

Nominal Characteristic Impedance	50 $\Omega$	Operating Temperature	-30 to +85°C
Rated Voltage	150V AC	Operating Relative Humidity	95% Max.
Frequency Range	0 to 3GHz		

Items	Specifications	Conditions
Contact Resistance	5m $\Omega$ Max.	Measured at 100mA Max.
Insulation Resistance	1000M $\Omega$ Min.	Measured at 500V DC
Withstanding Voltage	No insulation breakdown	500V AC for 60 sec.
V.S.W.R.*	1.3 Max.	Up to 3GHz (some 1GHz)
Mating Force (Extraction Force)	7.8N Min.	Measured with Applicable Connector
Mating Durability	Contact Resistance : 10m $\Omega$ Max.	500 times
Vibration Resistance	No electrical discontinuity of 1 $\mu$ s or more No damage, cracks, or parts dislocation	Frequency : 10 to 500Hz, Half amplitude: 0.75mm, Acceleration : 98m/s <sup>2</sup> , 10 times in each of the 3 axis
Shock Resistance	No electrical discontinuity of 1 $\mu$ s or more No damage, cracks, or parts dislocation	Acceleration : 490m/s <sup>2</sup> , Wave form: 11ms, Half-sine wave, 3 times in each of the 3 axis
Humidity	Insulation Resistance : 100M $\Omega$ Min. (in a high humidity environment) Insulation resistance : 1000M $\Omega$ Min. (in a dry environment) No damage, cracks, or parts dislocation	Left for 10 cycles (240 hours) in an environment with the temperature ranging from +25 to +65°C and the humidity ranging from 80 to 96%.
Heat Shock Resistance	No damage, cracks, or parts dislocation	(-55°C : 30 min. → +5 to +35°C : within 5 min. → +85°C : 30 min. → +5 to +35°C : within 5 min.) 5 cycles
Corrosion Resistance	No corrosion that impairs function.	Continuous 48 hours cycle in 5% salt water solution

Note : Ratings and standards may vary by products.

\* V.S.W.R. (Voltage Standing Wave Ratio) Measurement System

The above V.S.W.R. specification values were measured using the measurement system shown below.

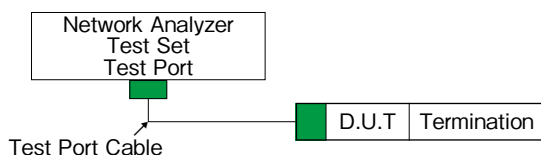

Note1 : The cable connector is measured with the connector attached to the applicable cable.

Note2 : Board type connectors were mounted to a 50  $\Omega$  board and measurements were conducted with connectors attached.

## Materials / Finish

Parts	Material	Finish	Remarks
Shell	Brass	Gold Plating or Nickel Plating	—
Male Contact	Brass	Gold Plating	—
Female Contact	Beryllium Steel	Gold Plating	—
Insulation	PTFE	—	Non-combustible Materials

Note : The contact's finish varies by product and refer to "UM Series Plating Specifications".

## Product Number Structure

Refer to the chart below when determining the product specifications from the product number.

### UM - Q P - 1.5VCR 3A(##)

①      ② ③                      ④                      ⑤

① Series Name	UM	④ 1) Plug, Jack : Applicable Cable  2) Receptacle, Plug Receptacle : Board Mounting Method	1.5, 1.5CR, 1.5VCR : 1.5D-2V 1.5W, 1.5WCR : 1.5D-2W 2.5CR : 2.5D-2V PC : PCB Mounting Type
② Lock Mechanism	Q : Push on Lock Type		
③ Connector Type	P : Straight Plug LP : Right Angle Plug J : Straight Jack PJ : Panel Jack R : Straight Receptacle LR : Right Angle Receptacle	⑤ Serial Number	

## Functional Diagram

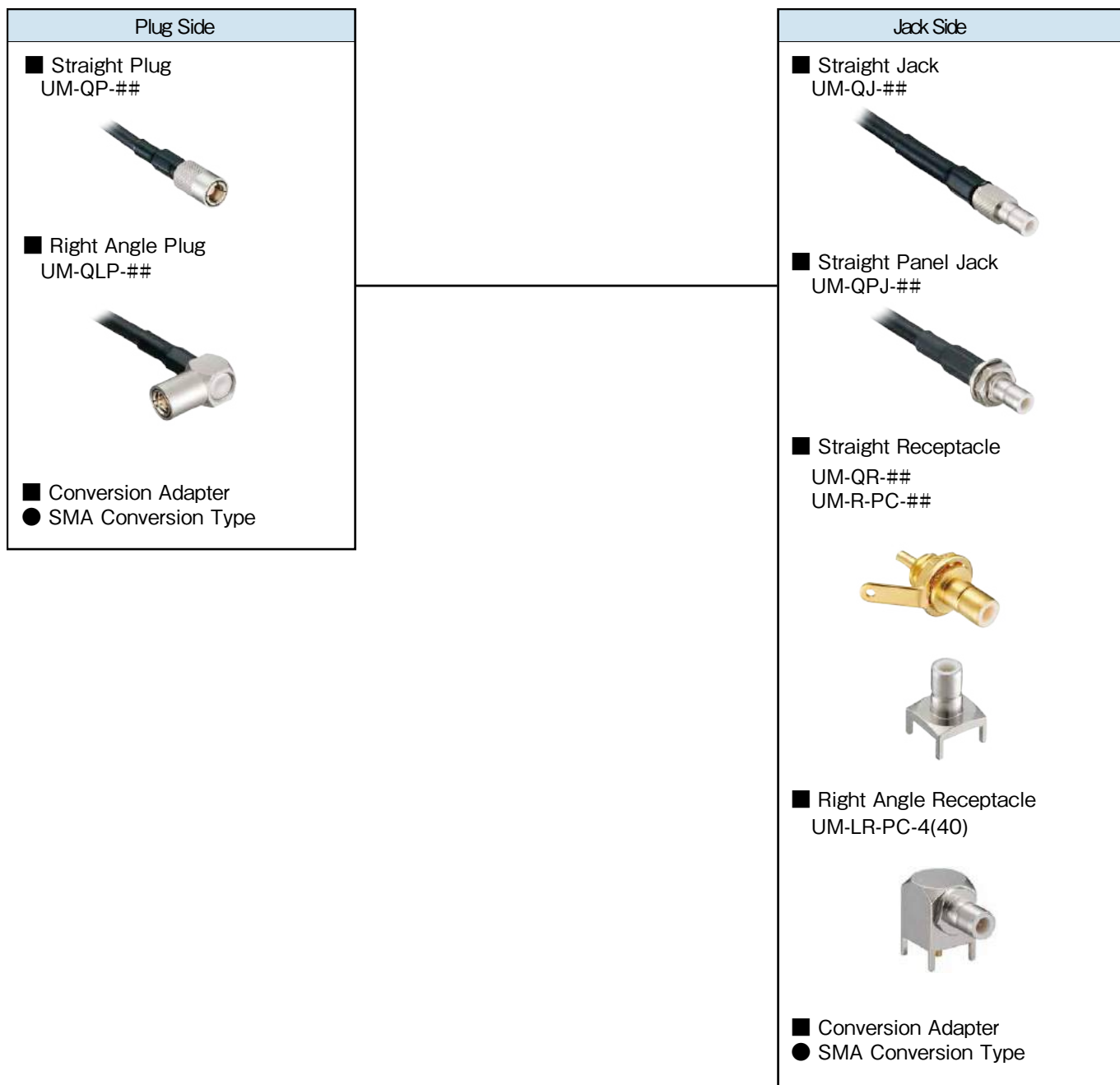

## Straight Plug

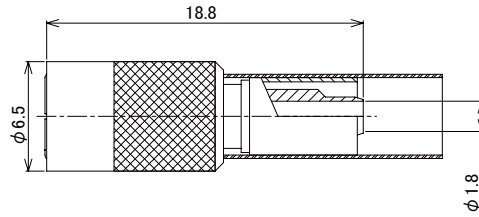

Part No.	HRS No.	Applicable Cable	Purchase Unit
UM-QP-1.5VCR3A(40)	CL0318-0190-0-40	1.5D-2V	20pcs per bag
UM-QP-1.5WCR3A(40)	CL0318-0176-0-40	1.5D-2W	100pcs per bag

## Right Angle Plug

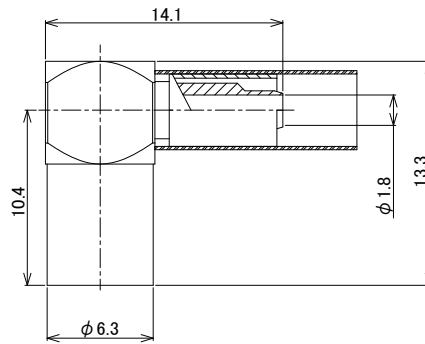

Part No.	HRS No.	Applicable Cable	Purchase Unit
UM-QLP-1.5-6(40)	CL0318-0162-5-40	1.5D-2V	20pcs per bag
UM-QLP-1.5W-6(40)	CL0318-0163-8-40	1.5D-2W	

## Straight Jack

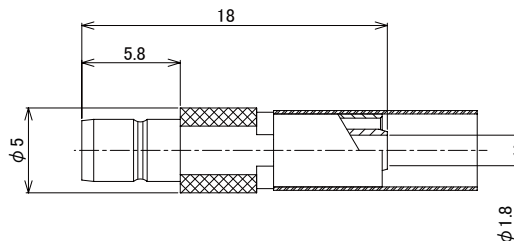

Part No.	HRS No.	Applicable Cable	Purchase Unit
UM-QJ-1.5VCR3A(40)	CL0318-0215-0-40	1.5D-2V	20pcs per bag

## Panel Jack

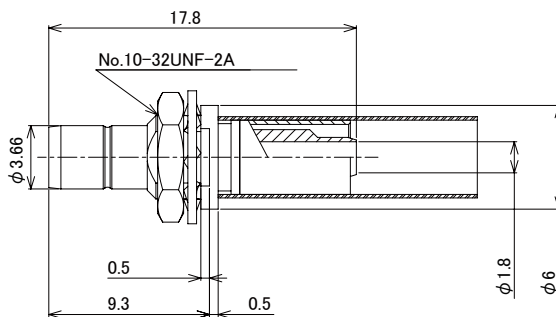

Part No.	HRS No.	Applicable Cable	Purchase Unit
UM-QPJ-1.5VCR3B(40)	CL0318-0203-0-40	1.5D-2V	20pcs per bag

## Straight Receptacle

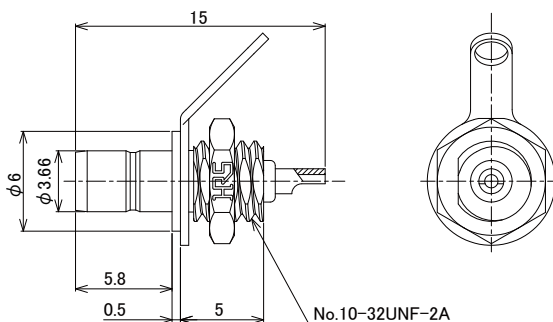

Part No.	HRS No.	Purchase Unit
UM-QR-1(40)	CL0318-0011-0-40	10pcs per bag

## ● PCB Mounted Type

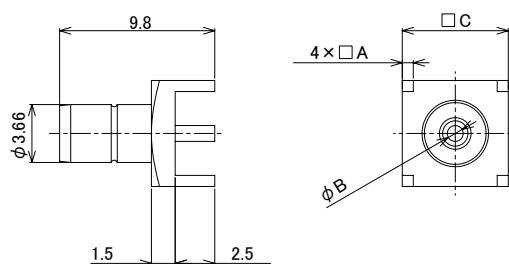

Part No.	HRS No.	A	φ B	C	Purchase Unit
UM-R-PC(40)	CL0318-0032-0-40	0.7	1.0	6.7	100pcs per bag
UM-R-PC-1(40)	CL0318-0054-2-40	0.6	0.8	5.7	

## Right Angle Receptacle

### ● PCB Mounted Type

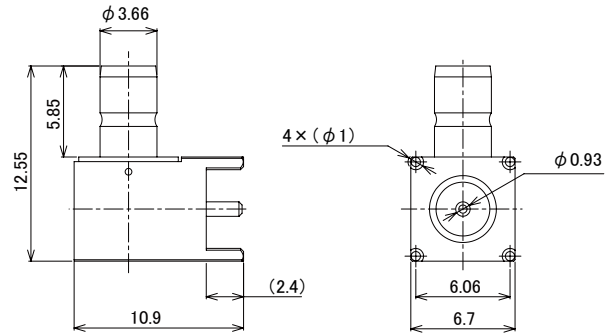

Part No.	HRS No.	Remarks	Purchase Unit
UM-LR-PC-A(40)	CL0318-0229-0-40	Exterior : Nickel Plating	50pcs per tray
UM-LR-PC-A(41)	CL0318-0229-0-41	Exterior : Gold Plating	

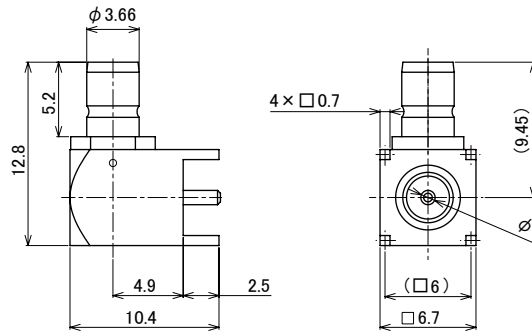

Part No.	HRS No.	Purchase Unit
UM-LR-PC-4(40)	CL0318-0150-6-40	50pcs per tray

### ■ Mounting Hole Dimensions

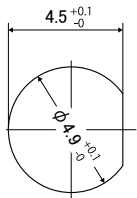

UM-QR-1(40)

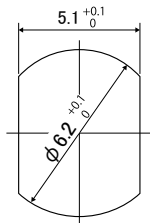

UM-QPJ-1.5VCR3B(40)

### ■ PCB Dimensions

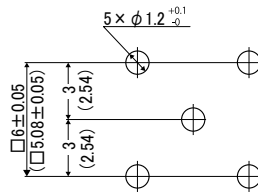

UM-R-PC(40)  
UM-LR-PC-A(4#)  
UM-R-PC-1(40)

Note : For UM-R-PC-1, the dimensions in ( ) apply.



## Termination Tools

The following table lists the tools used for the UM series according to the applicable cable.

Applicable Cable	Part No.	Tool Name	
		For Outer Conductors	Lid Presser Bar
1.5D-2V	UM-QP-1.5VCR3A(40)	HT303/UM.MSS-T-1	—
	UM-QLP-1.5-6(40)	HT303/UM.MSS-T-1	UM-T-1(MARU4.75)
	UM-QJ-1.5VCR3A(40)	HT303/UM.MSS-T-1	—
	UM-QPJ-1.5VCR3B(40)	HT303/UM.MSS-T-1	—
1.5D-2W	UM-QP-1.5WCR3A(40)	HT303/PO-P-2-T	—
	UM-QLP-1.5W-6(40)	HT303/PO-P-2-T	UM-T-1(MARU4.75)

## Connection Method

UM-QP-1.5VCR3A(40), UM-QP-1.5WCR3A(40), UM-QJ-1.5VCR3A(40), UM-QPJ-1.5VCR3B(40)

### Crimping System

#### 1. Insertion of Heat Shrink Tube and Crimping Sleeve

Insert the heat-shrink tube and crimping sleeve into the cable as shown.

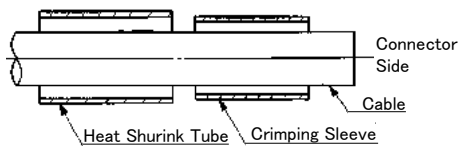

Note : The heat shrink tube may be cable jacket. In the case of cable jacket, insert it so that the thicker side is on the connector side.

#### 2. Cable Terminal Processing

Terminal processing is performed as shown in the figure. Dimensions are as shown in the table below.

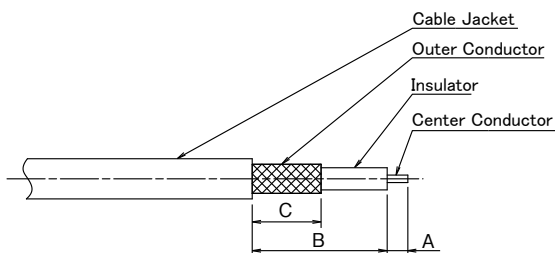

Part No.	A	B	C
UM-QP-1.5VCR3A(40)	1.5	9.8 ± 0.2	5 ± 0.2
UM-QP-1.5WCR3A(40)			
UM-QJ-1.5VCR3A(40)	2.5 ± 0.3	6.5 ± 0.2	4.7 ± 0.3
UM-QPJ-1.5VCR3B(40)	2.5 ± 0.3	6.3 ± 0.2	4.9 ± 0.3

Note : The outer and center conductors of the cable shall not be damaged.

### 3. Soldering of the Center Contact

- (1) A preliminary solder is applied to the solder hole of the center contact.
- (2) A cable center conductor is inserted into the solder hole and soldered.

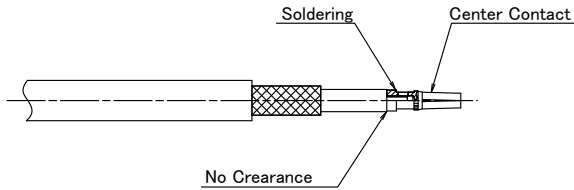

Note 1 : Be careful not to melt the cable insulation.

Note 2 : Remove excess solder with a knife, etc. If there is excess solder, the center contact may not be fully inserted into the connector body.

### 4. Insert the Cable into the Connector Body

- (1) The cable insertion is completed when the tip of the center contact coincides with the end face A of the connector insulator.
- (2) Be careful not to allow the cable braid to enter the connector.

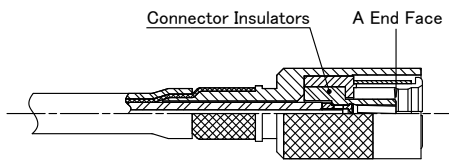

### 5. Crimping Sleeve

- (1) Move the crimping sleeve to the position shown.
- (2) Crimp with the special tool shown in the table below.

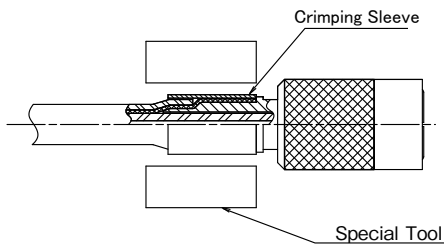

Part No.	Specialized Tool Part No. and Hole
UM-QP-1.5VCR3A(40)	HT303/UM.MSS-T-1 (1.5 holes)
UM-QP-1.5WCR3A(40)	HT303/PO-P-2-T
UM-QJ-1.5VCR3A(40)	HT303/UM.MSS-T-1 (1.5 holes)
UM-QPJ-1.5VCR3B(40)	HT303/UM.MSS-T-1 (1.5 holes)

### 6. Installing the Heat Shrink Tube

Move the heat shrink tube to the connector body side as shown in the figure. Shrink by heating with a heat gun or the like at the position shown in the figure.

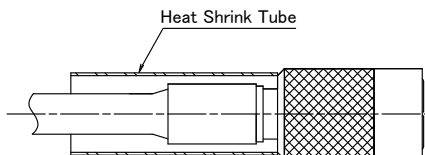

Note : The shape of the connector is shown in the representative example.

## Conversion Adapter List

Mating Part 1		Mating Part 2		Part No.	HRS No.
Series Name	Mating Part	Series Name	Mating Part		
UM	Plug	HRM	Jack	UM.P-HRM.J(40)	CL0311-0176-5-40
	Jack			HRMJ-UMJ(40)	CL0311-0164-6-40

## UM Series Plating Specifications

The center contact of the UM series is gold plated. There are gold plated and nickel plated external contacts. The table below shows the plating specifications by product number.

Connector Type	Part No.	HRS No.	Center	External	
			Gold	Gold	Nickel
Plug	UM-QP-1.5VCR3A(40)	CL0318-0190-0-40	○		○
	UM-QP-1.5WCR3A(40)	CL0318-0176-0-40	○		○
Right Angle Plug	UM-QLP-1.5-6(40)	CL0318-0162-5-40	○		○
	UM-QLP-1.5W-6(40)	CL0318-0163-8-40	○		○
Receptacle	UM-QR-1(40)	CL0318-0011-0-40	○	○	
Jack	UM-QJ-1.5VCR3A(40)	CL0318-0215-0-40	○		○
Panel Jack	UM-QPJ-1.5VCR3B(40)	CL0318-0203-0-40	○		○
For PCB	Receptacle	UM-R-PC(41)	CL0318-0032-0-41	○	○
		UM-R-PC(40)	CL0318-0032-0-40	○	
		UM-R-PC-1(41)	CL0318-0054-2-41	○	○
		UM-R-PC-1(40)	CL0318-0054-2-40	○	
	Right Angle Receptacle	UM-LR-PC-4(40)	CL0318-0150-6-40	○	

## While Taking into Consideration

Specifications mentioned in this catalog are reference values.

When considering to order or use this product, please review the Drawing and Product Specifications sheets.

Use an appropriate cable when using the connector in combination with cables.

If considering usage of a non-specified cable, please contact your sales representative.

If assembly process is done by jigs & tools which are not identified by Hirose, the warranty of the product may be affected.

If considering usage for below mentioned applications, please contact your sales representative.

In cases where the application will demand a high level of reliability, such as automotive, medical instruments, public infrastructure, aerospace/defense etc. Hirose must review before assurance of reliability can be given.