

Sep. 1. 2024 Copyright 2024 HIROSE ELECTRIC CO., LTD. All Rights Reserved.  
In case of consideration for using Automotive equipment / device which demand high reliability, kindly contact our sales window correspondents.

1		2			3			4		
COUNT	DESCRIPTION OF REVISIONS	BY	CHKD	DATE	COUNT	DESCRIPTION OF REVISIONS	BY	CHKD	DATE	
△					△					
△					△					
△					△					

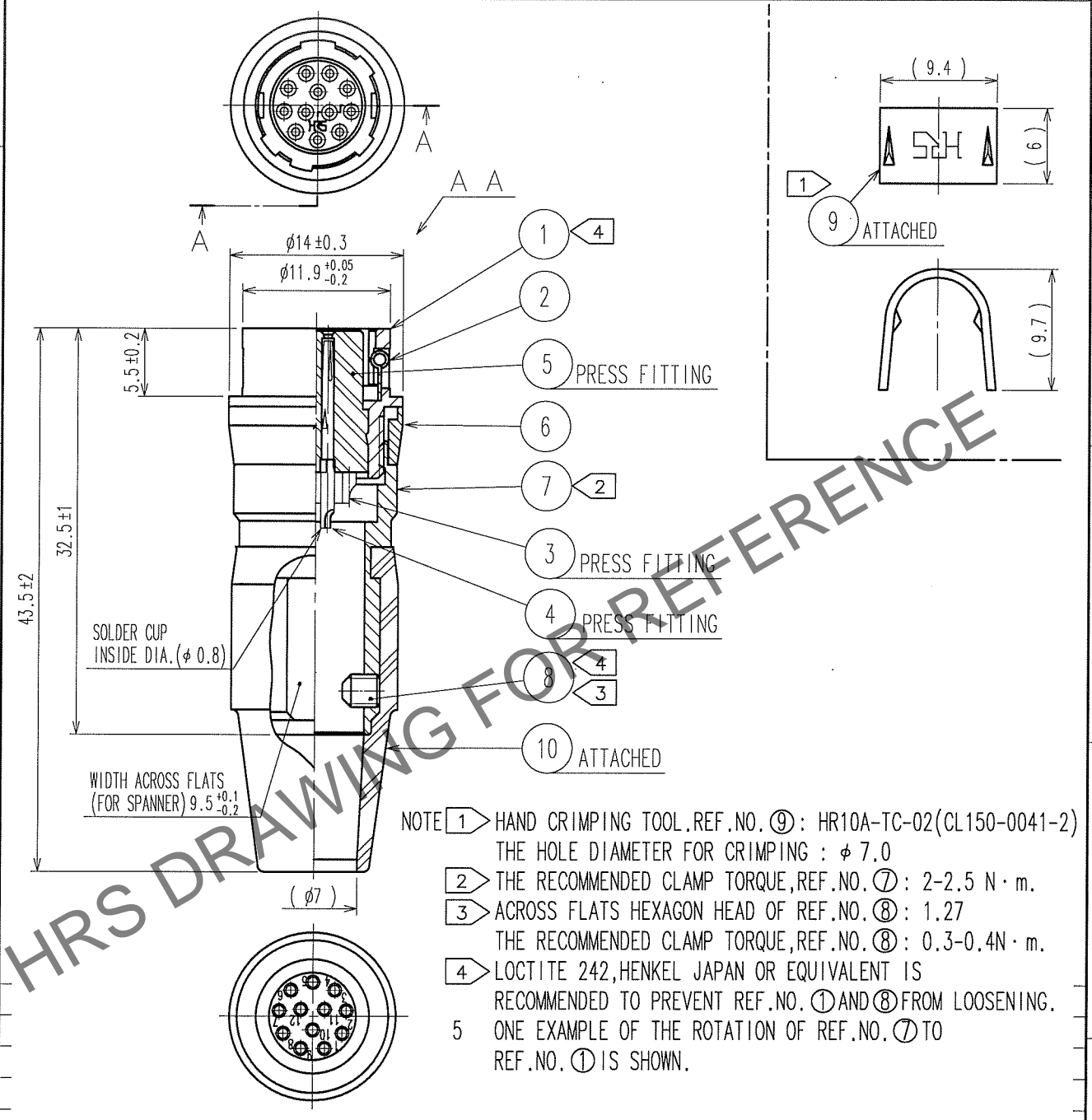

- NOTE
- ① HAND CRIMPING TOOL, REF. NO. ⑨: HR10A-TC-02 (CL150-0041-2)  
THE HOLE DIAMETER FOR CRIMPING :  $\phi 7.0$
  - ② THE RECOMMENDED CLAMP TORQUE, REF. NO. ⑦: 2-2.5 N · m.
  - ③ ACROSS FLATS HEXAGON HEAD OF REF. NO. ⑧: 1.27  
THE RECOMMENDED CLAMP TORQUE, REF. NO. ⑧: 0.3-0.4 N · m.
  - ④ LOCTITE 242, HENKEL JAPAN OR EQUIVALENT IS RECOMMENDED TO PREVENT REF. NO. ① AND ⑧ FROM LOOSENING.
  - ⑤ ONE EXAMPLE OF THE ROTATION OF REF. NO. ⑦ TO REF. NO. ① IS SHOWN.

5	POLYAMIDE	(BLACK) UL94V-0	10	CR	(BLACK)
4	PHOSPHOR BRONZE	GOLD PLATING 0.2 $\mu$ m min.	9	BRASS	
3	PHOSPHOR BRONZE	NICKEL UNDER PLATING 2 $\mu$ m min.	8	STEEL	NICKEL PLATING HEXAGON SOCKET SET SCREW M2.6×0.45×3
2	STAINLESS STEEL		7	BRASS	MATTE FINISH NICKEL PLATED
1	ZINC ALLOY	MATTE FINISH NICKEL PLATED	6	BRASS	MATTE FINISH NICKEL PLATED
NO.	MATERIAL	FINISH, REMARKS	NO.	MATERIAL	FINISH, REMARKS

CODE NO. (OLD)	CL	DRAWN	DESIGNED	CHECKED	APPROVED	RELEASED
		<i>D. Matsume</i>	<i>D. Matsume</i>	<i>E. Kunita</i>	<i>M. Sato</i>	
		05.10.01	05.10.01	05.10.03	05.10.14	

 SACLE 2 : 1 UNITS mm	DRAWING NO.	PART NO.
	EDC4-020555-74	HR10A-10J-12S(74)
 HIROSE ELECTRIC CO., LTD.	CODE NO.	
	CL110-0405-8-74	1/1

TO  
R