

Sep. 1. 2024 Copyright 2024 HIROSE ELECTRIC CO., LTD. All Rights Reserved. In case of consideration for using Automotive equipment / device which demand high reliability, kindly contact our sales window correspondents.

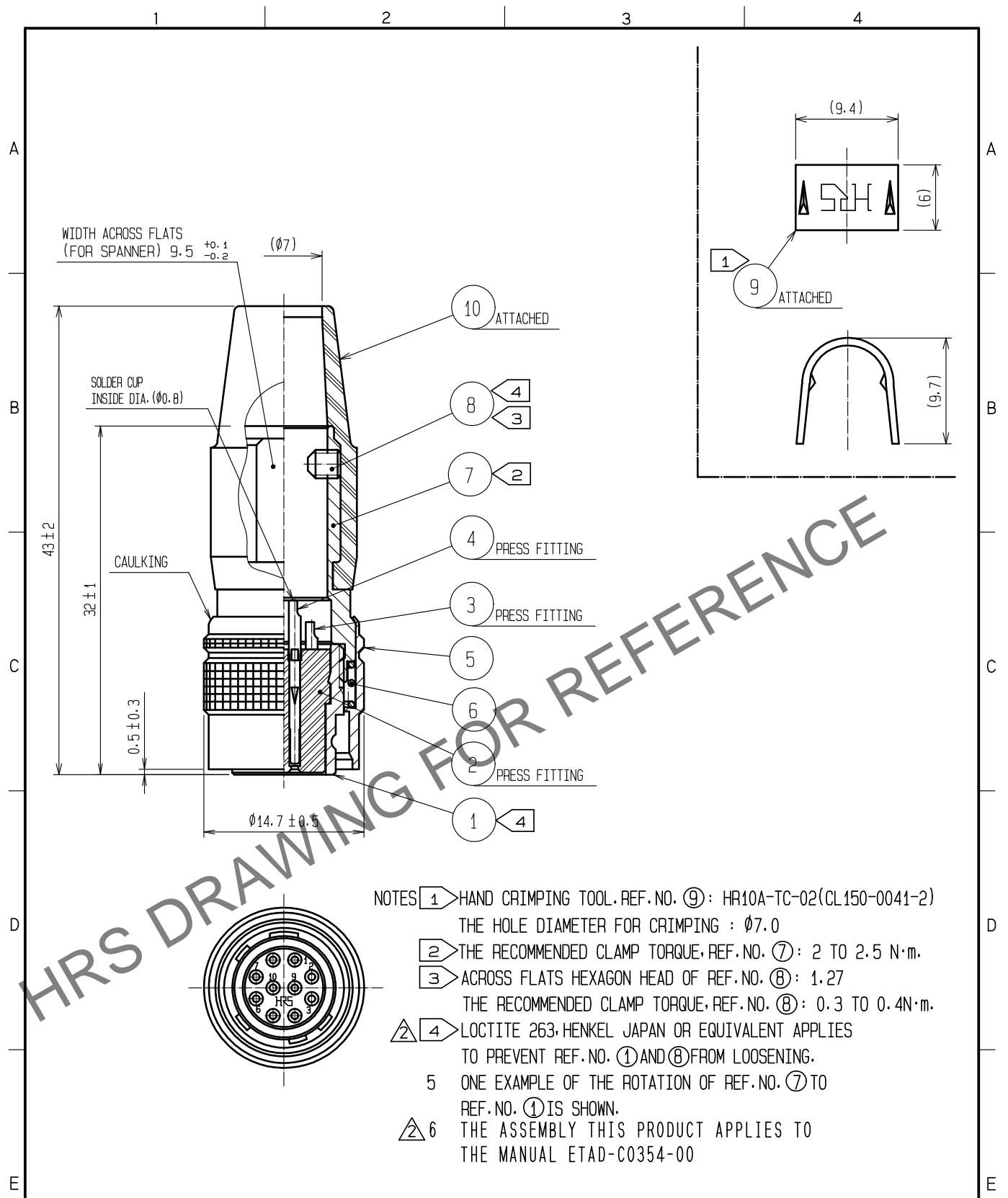

- NOTES
- ① HAND CRIMPING TOOL. REF. NO. ⑨: HR10A-TC-02(CL150-0041-2)
THE HOLE DIAMETER FOR CRIMPING : $\phi 7.0$
 - ② THE RECOMMENDED CLAMP TORQUE, REF. NO. ⑦: 2 TO 2.5 N·m.
 - ③ ACROSS FLATS HEXAGON HEAD OF REF. NO. ⑧: 1.27
THE RECOMMENDED CLAMP TORQUE, REF. NO. ⑧: 0.3 TO 0.4 N·m.
 - ④ LOCTITE 263, HENKEL JAPAN OR EQUIVALENT APPLIES TO PREVENT REF. NO. ① AND ⑧ FROM LOOSENING.
 - ⑤ ONE EXAMPLE OF THE ROTATION OF REF. NO. ⑦ TO REF. NO. ① IS SHOWN.
 - ⑥ THE ASSEMBLY THIS PRODUCT APPLIES TO THE MANUAL ETAD-C0354-00

5	BRASS	MATTE FINISH NICKEL PLATED	10	CR	(BLACK)
4	PHOSPHOR BRONZE	SILVER PLATING 2#m min.	9	BRASS	
3	PHOSPHOR BRONZE		8	STEEL	NICKEL PLATING HEXAGON SOCKET SET SCREW M2.6X0.45X3
2	POLYAMIDE	(BLACK) UL94V-0	7	BRASS	NICKEL PLATING
1	ZINC ALLOY	MATTE FINISH NICKEL PLATED	6	STEEL	NICKEL PLATING
NO.	MATERIAL	FINISH . REMARKS	NO.	MATERIAL	FINISH . REMARKS

UNITS mm		SCALE 2 : 1	COUNT ② 2	DESCRIPTION OF REVISIONS DIS-C-00016953	DESIGNED HT. ZENBA	CHECKED EJ. KUNII	DATE 20240220
HIROSE ELECTRIC CO., LTD. APPROVED : MO. SATOH 20051020 CHECKED : EJ. KUNII 20051020 DESIGNED : DS. MATSUNE 20051019 DRAWN : DS. MATSUNE 20051019				DRAWING NO. EDC4-021367-73 PART NO. HR10A-10P-10S(73) CODE NO. CL0110-0408-6-73			