

Jul.1.2024 Copyright 2024 HIROSE ELECTRIC CO., LTD. All Rights Reserved.
 In case of consideration for using Automotive equipment / device which demand high reliability, kindly contact our sales window correspondents.

1 2 3 4 5 6 7 8

A
B
C
D
E
F

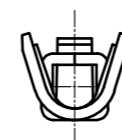
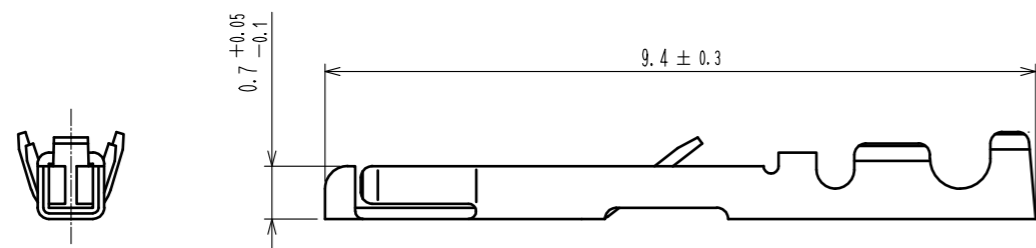
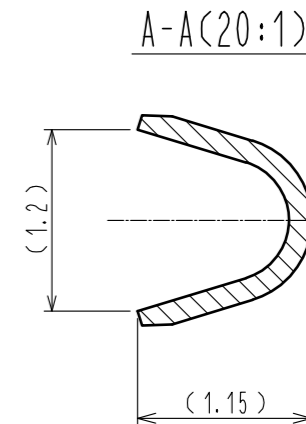
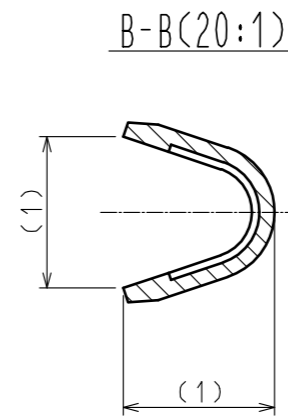
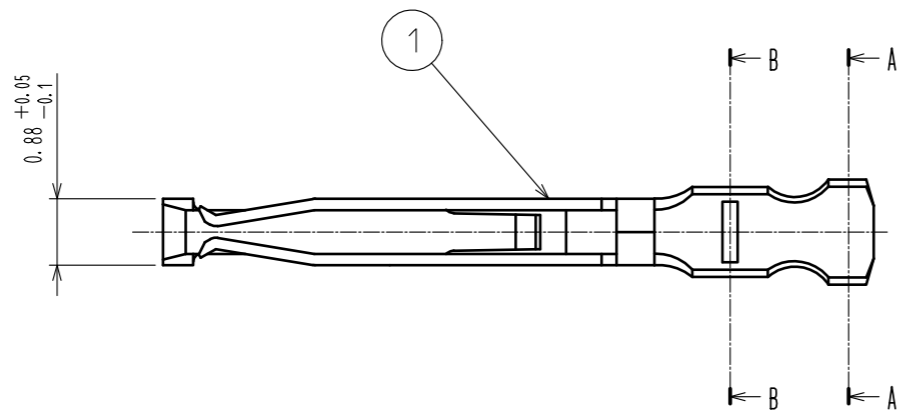

3 FIG.1

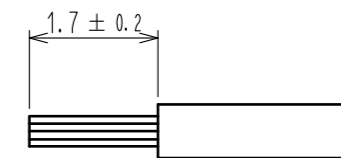

HRS DRAWING FOR REFERENCE

- NOTES
- 1 THIS PRODUCT IS APPLY TO THE WIRE AWG#30(WIRE JACKET DIAMETER ϕ 0.71 MAX).
 - 2 PER PACK : 100 CONTACTS.
 - 3 RECOMMEND CABLE PREPARATION DIMENTION ARE SHOWN IN FIG.1.
 - 4 APPLICABLE OPERATION CRIMP TOOL:HR25-TA3032HC

NO.	MATERIAL	FINISH . REMARKS	NO.	MATERIAL	FINISH . REMARKS
1	PHOSPHER BRONZE				CANTACT AREA: GOLD 0.2 μ m min. TERMINAT AREA:NICKEL PLATING 1 μ m min. UNDER PLATING :NICKEL PLATING 1 μ m min.

UNITS	SCALE	COUNT	DESCRIPTION OF REVISIONS	DESIGNED	CHECKED	DATE
mm	10:1	1				
HIROSE ELECTRIC CO., LTD.			APPROVED :EJ. KUNII	15.10.05	DRAWING NO. EDC-110401-00-00	
			CHECKED :EJ. KUNII	15.10.05	PART NO. HR25-SC-111	
			DESIGNED :WR. AJIRO	15.10.05	CODE NO. CL125-0421-3-00	
			DRAWN :WR. AJIRO	15.10.05	1/1	

FORM HC0011-5-7 1 2 3 4 5 6 7 8