

Jun.1.2026 Copyright 2026 HIROSE ELECTRIC CO., LTD. All Rights Reserved.
In case of consideration for using Automotive equipment / device which demand high reliability, kindly contact our sales window correspondents.

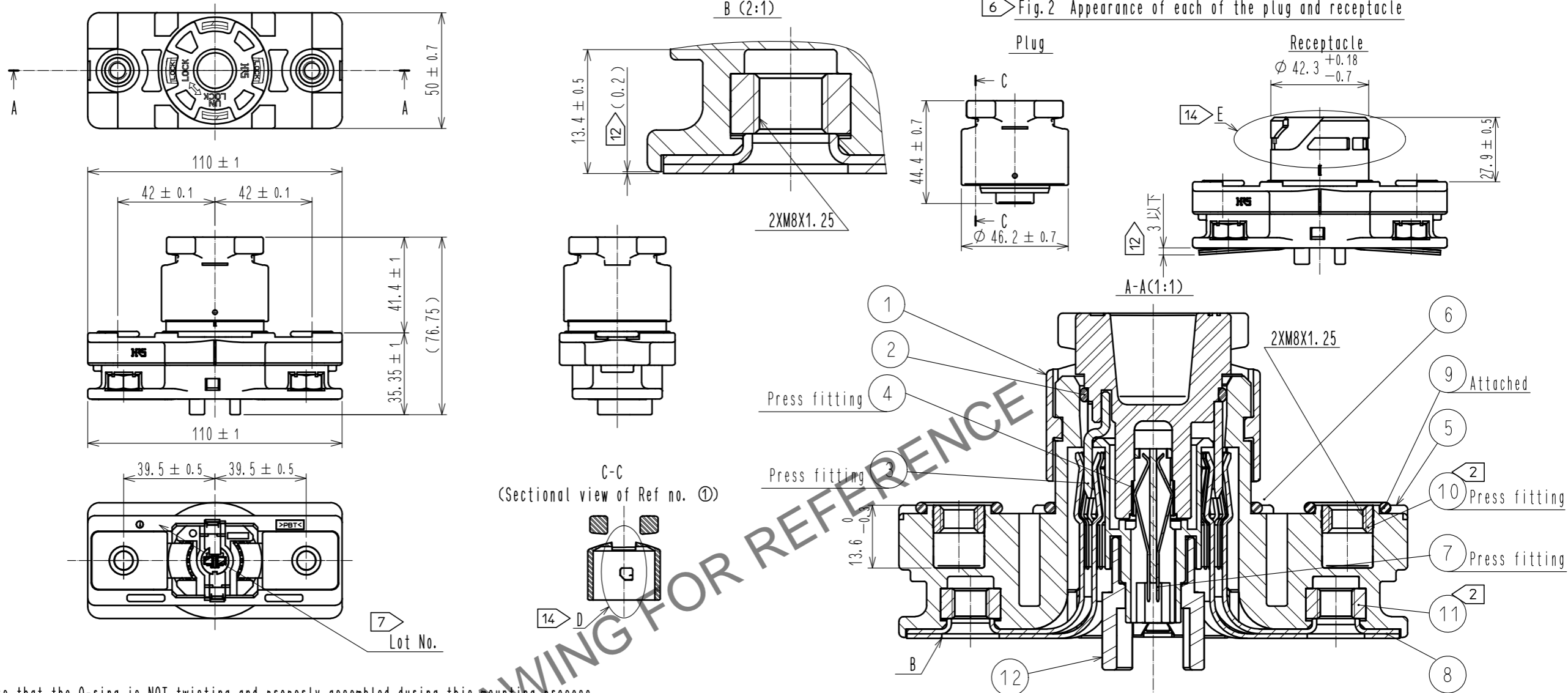

6 Fig.2 Appearance of each of the plug and receptacle

- Notes
- 1 Make sure that the O-ring is NOT twisting and properly assembled during this mounting process.
 - 2 Use ring terminal M8 for the power contact. The recommended tightening torque of Ref No. ⑩ and ⑪ is 6.0 to 6.5 N·m. Be sure to tighten Ref No. ⑩ with the panel installed as shown in Fig.1. Do not tighten the bolt by itself during inspection.
 - 3 The panel material is assumed to be aluminum. The above recommended torque is the one when aluminum is used. Depending on the hardness of the material and the smoothness of the surface, the load on the product by tightening the screw will vary. Therefore, when selecting other materials, please confirm and, if necessary, lower the tightening torque. Recommended bolt size are as follows.
- Ref No. ⑩ : Screw size M8, Pitch 1.25 Length 10 to 12 mm.
(For panel thickness, Refer to the next page Fig.1)
- Ref No. ⑪ : Screw size M8, Pitch 1.25 Length 12 to 15 mm.
(Assume ring terminal thickness t = 2.5 to 3. When using ring terminal with different thickness, choose appropriate bolt size per the thickness.) To prevent loosening, use LOCTITE 243, HENKEL JAPAN or equivalent.
 - 4 Mating connector at signal contact side is as follows.
- | | | | |
|---------------|------------------|-----------------|----------------------------|
| Connector | GT8E-2S-2C | CL758-0030-6-00 | |
| Crimp contact | GT8E-2022SCF(01) | CL758-0033-4-01 | For AWG#20~22 Reel contact |
| | GT8E-2428SCF(01) | CL758-0055-7-01 | For AWG#24~28 Reel contact |
- 5 Fig.1 shows the recommended panel cut out dimensions.
 - 6 Roughness on the panel surface indicated by for water sealing must be $\sqrt{Rz} 3.2$
 - 7 This product is delivered with the plug and receptacle unmated as shown in Fig. 4. Appearance of each of the plug and receptacle are shown in Fig.2. Lot No. is marked in one the indicated part shown.
 - 8 Make sure the locking system firmly completed before using the this product. Fig.3 indicates rotated position of the plug and the receptacle with locking completed. Also, "LOCK" marking on the receptacle can be seen from the plug hole.

- WARNING 9 Never engage/disengage the plug while the power contacts (Ref No. ③ and Ref. No. ⑥) are energized. Signal contacts are sequentially connected after the power line in the plug engagement, and disconnected before the power line in the disengagement. Therefore, use the product with the circuit to avoid hot-plugging provided. Mating sequence of power line and signal line are shown in Fig. 1 along with the appearance and circuit of each state.
- 10 Rotated position of the plug and the receptacle are is shown as an exapmle.
- 11 For product handling, refer to the Operation guide ETAD-C0320.
- 12 Female contact Ref. No. ⑧ is loose before the bolt is attached to Ref. No. ⑩ and the female contact is movable as shown in Fig. 2, but stabilized to the receptacle after the screw fix. Therefore the looseness is eliminated for the use and does not affect its performance. (0.2) shown in Fig. ⑧ is the state when the bolt is tightened.
- WARNING 13 Engage the plug to the receptacle after all the assembly including cable wiring are completed for safety.
- 14 There are traces of white lubricant dry in the vicinity of that shown in the illustration D and E. It doe's not adversely affect the performance.

6	Hydrogenation acrylonitrile butadiene rubber	(Black)	12	Polybutylene terephthalate	(Black)
5	Polybutylene terephthalate	(Orange)	11	Brass	Nickel plating
4	Copper alloy	Gold plating 0.2μm MIN	10	Brass	Nickel plating
3	Copper	Silver plating 3μm MIN	9	Hydrogenation acrylonitrile butadiene rubber	(Black)
2	Hydrogenation acrylonitrile butadiene rubber	(Black)	8	Copper alloy	Silver plating 3μm MIN
1	Polybutylene terephthalate	(Orange)	7	Copper alloy	Gold plating 0.2μm MIN
NO.	MATERIAL	FINISH . REMARKS	NO.	MATERIAL	FINISH . REMARKS

UNITS		SCALE	COUNT	DESCRIPTION OF REVISIONS	DESIGNED	CHECKED	DATE
mm		1 : 2	1	DIS-C-00018068	TY. SUZUKI	KS. TAKAHASHI	20241001
APPROVED : TP. KOMATSU 20220815				DRAWING NO. EDC-119542-06-00			
CHECKED : HY. KOBAYASHI 20220815				PART NO. EM30MSD-A(06)			
DESIGNED : TY. SUZUKI 20220812				CODE NO. CL0138-0206-0-06			
DRAWN : TY. SUZUKI 20220812							

Jun.1.2026 Copyright 2026 HIROSE ELECTRIC CO., LTD. All Rights Reserved.
 In case of consideration for using Automotive equipment / device which demand high reliability, kindly contact our sales window correspondents.

4 Fig.1 The recommended panel dimention (t = 2 to 4.5)

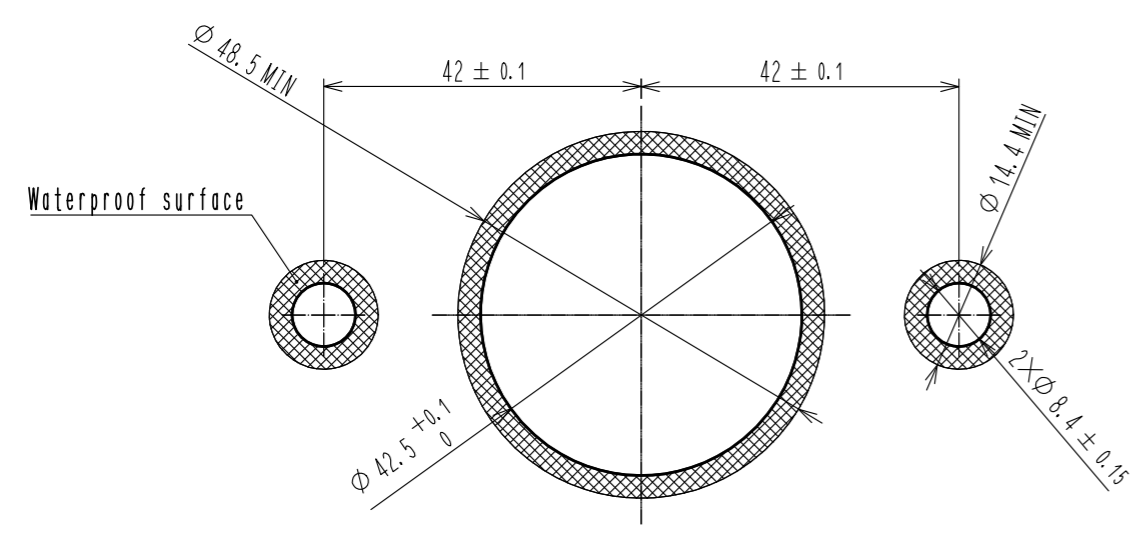

8 Fig.3 State of locked

LOCK indication is visible.
 Top face of HRS logo becomes parallele to the shortsides of the receptacle.

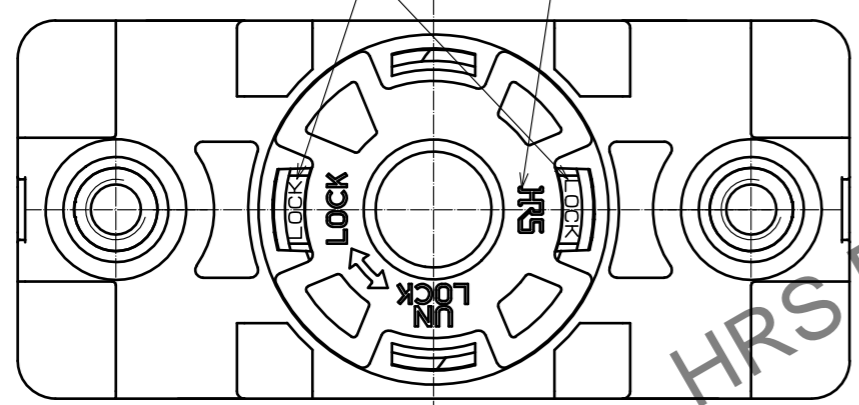

9 Table.1 Connection Timing (Power line and signal line)

Ⓐ-Ⓑ Power line
 Ⓒ-Ⓓ Signal line

State	Before mating	Insertion plug	Rotated and Locked	Unlocked	Unmated
Appearance					
Connection		Power line closed. Signal line open. No power current.	Signal line closed. Power Line ON	Signal line open. Power line OFF.	
Circuit diagram					
	Plug Receptacle	Plug Receptacle	Plug Receptacle	Plug Receptacle	Plug Receptacle

5 Fig.4 View of packing style

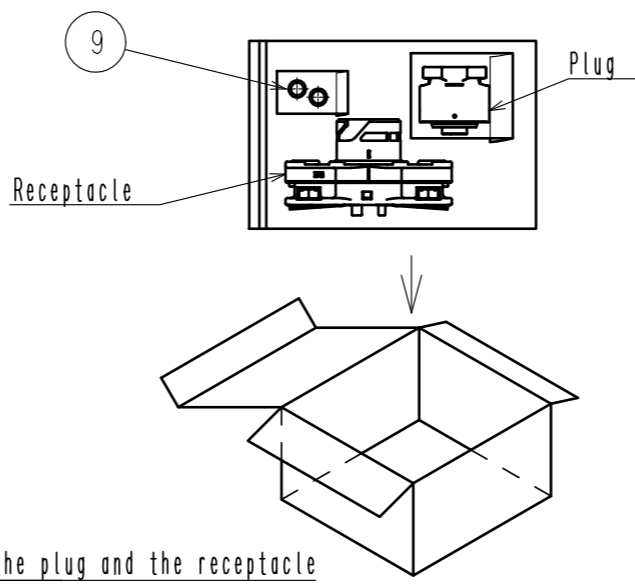

3 View of signal contact side

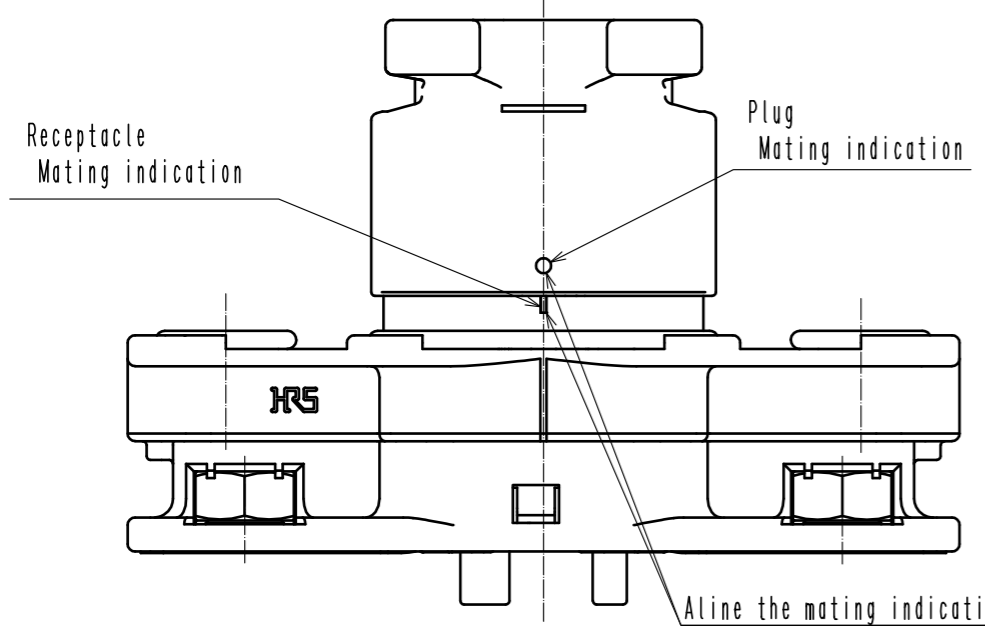
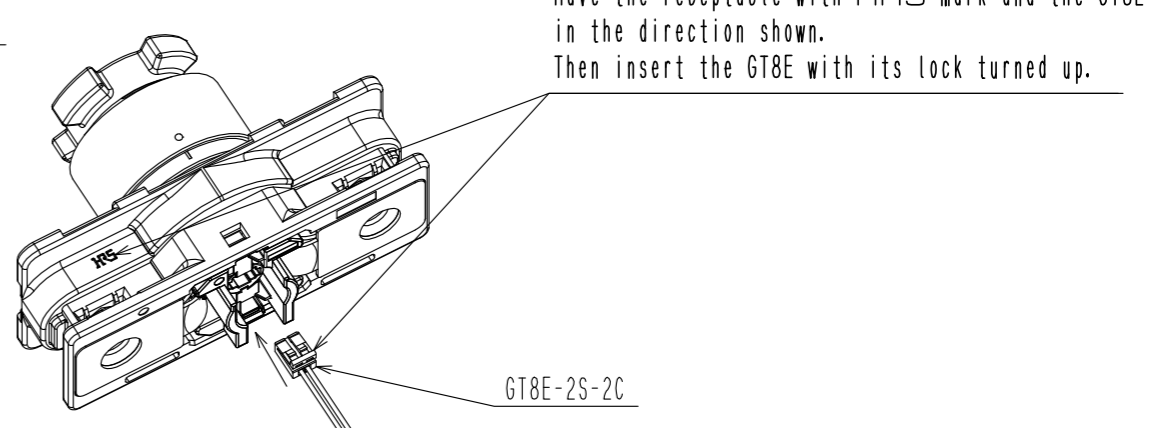

HRS

DRAWING NO.	EDC-119542-06-00
PART NO.	EM30MSD-A(06)
CODE NO.	CL0138-0206-0-06

1/2