

Feb.1.2025 Copyright 2025 HIROSE ELECTRIC CO., LTD. All Rights Reserved.
 In case of consideration for using Automotive equipment / device which demand high reliability, kindly contact our sales window correspondents.

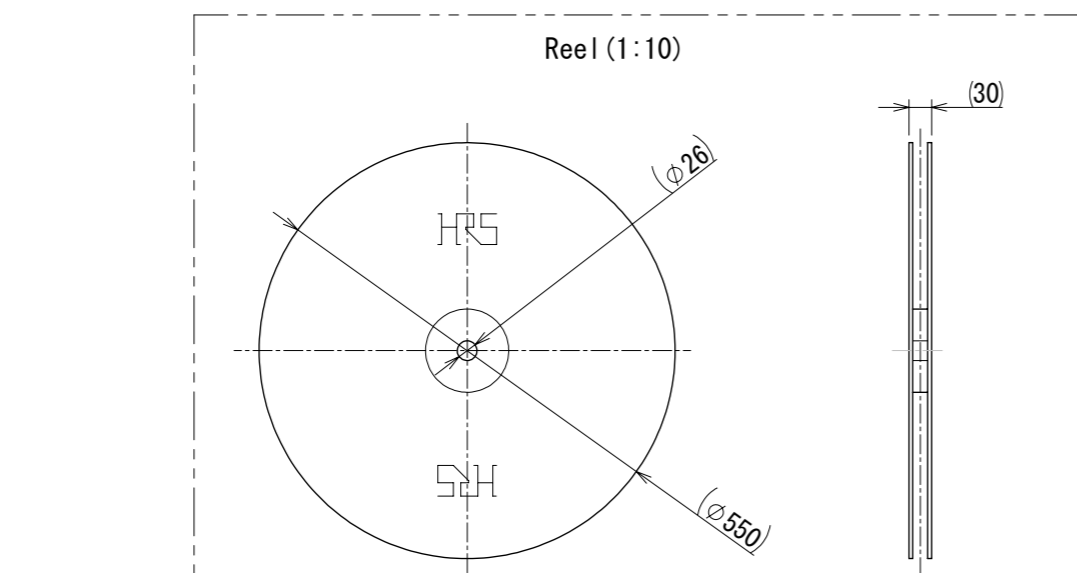
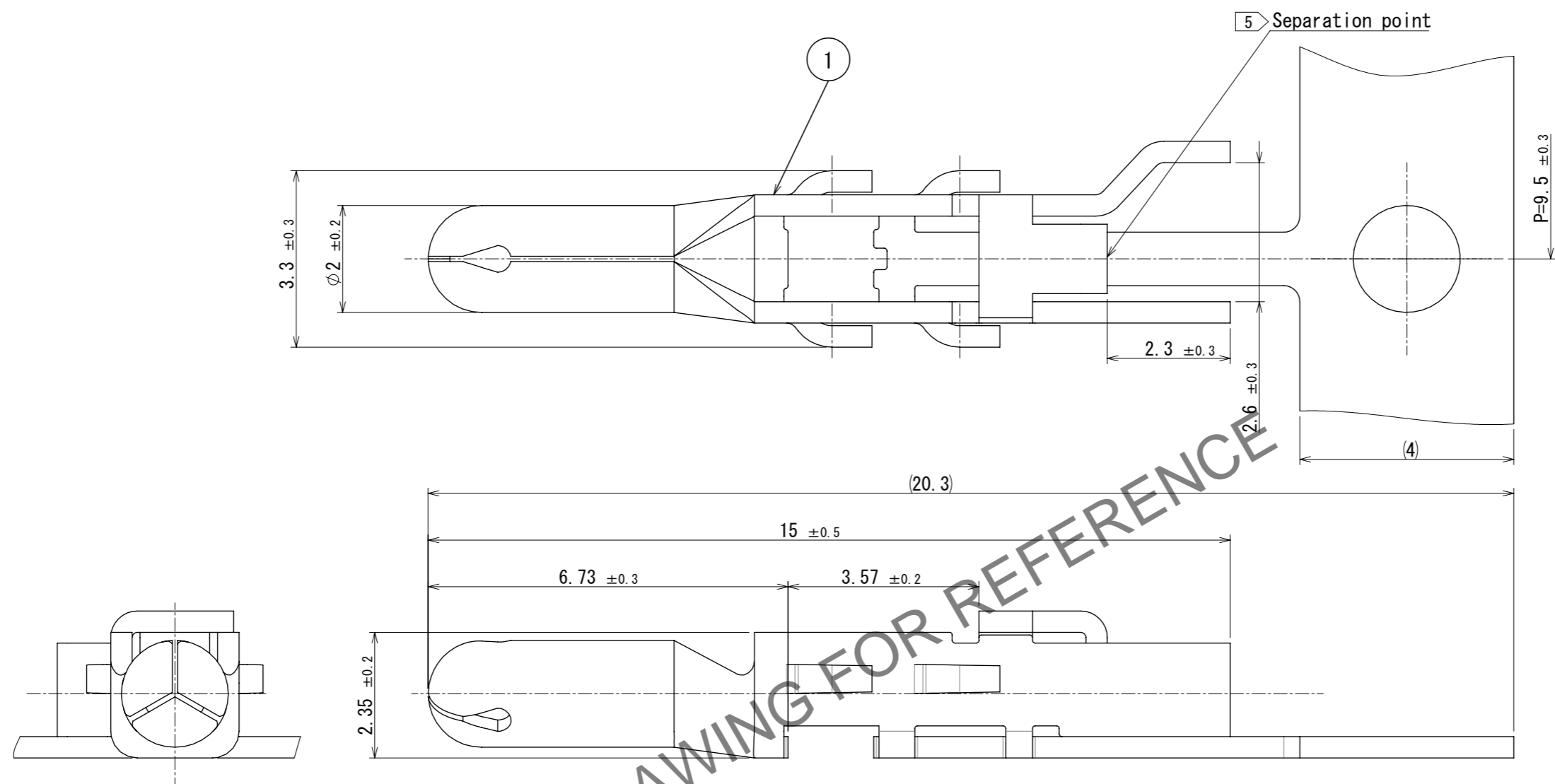

- Notes
- 1 The product is apply to the wire AWG#14 to 16 (Wire jacket diameter: φ2.6 to 3.0)
 - 2 Per reel : 5,000 contacts.
 - 3 Surface plating : Tin plating 1 μm min.
Under plating : Nickel plating 1 μm min.
 - 4 The assembly of this product applies to the manual ETAD-C0454-00.
 - 5 Bend the terminal and carrier up and down in the axial direction of the pilot hole to separate them.
 - 6 This product is coated with lubricant on the surface.
Oil residues may be confirmed, but there is no problem with performance.
In addition, if dust etc. adhere, remove it with an air blow or the like before using.

△ CAD change

1	Copper alloy	3							
NO.	MATERIAL	FINISH	REMARKS	NO.	MATERIAL	FINISH	REMARKS		
UNITS		SCALE	COUNT	DESCRIPTION OF REVISIONS			DESIGNED	CHECKED	DATE
mm		10:1	1	DIS-C-00018241			SY. KONDO	KI. NAGANUMA	2024.09.13
HRS HIROSE ELECTRIC CO., LTD.		APPROVED : YH. YAMADA	2020.01.28	DRAWING NO.		EDC-390466-00-00			
		CHECKED : HN. TANAKA	2020.01.28	PART NO.		BH12-P-213			
		DESIGNED : SH. KOYAMA	2020.01.28	CODE NO.		CL0140-0016-0-00			
		DRAWN : SH. KOYAMA	2020.01.28						