

Jun.1.2024 Copyright 2024 HIROSE ELECTRIC CO., LTD. All Rights Reserved.  
In case of consideration for using Automotive equipment / device which demand high reliability, kindly contact our sales window correspondents.

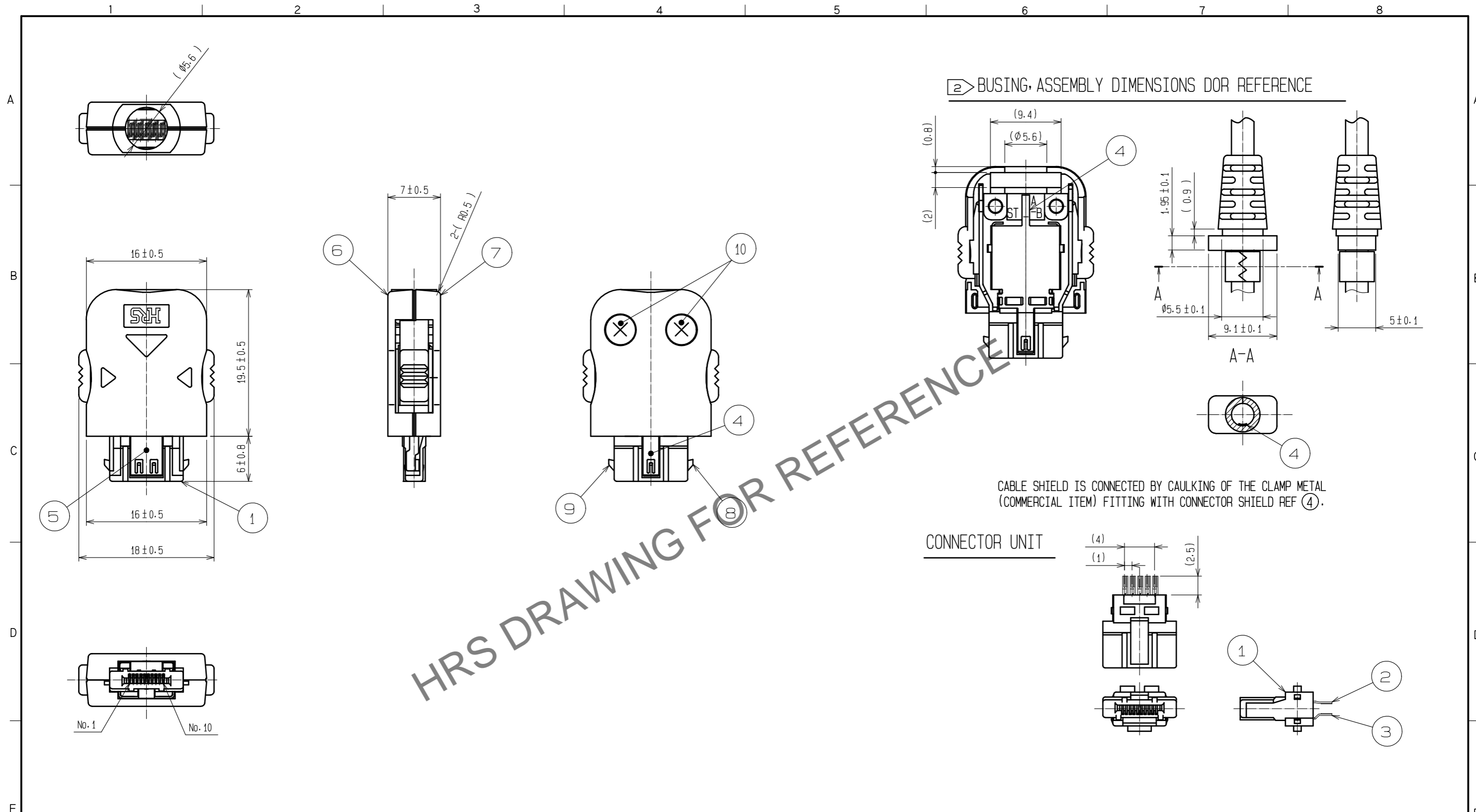

② BUSHING, ASSEMBLY DIMENSIONS FOR REFERENCE

CABLE SHIELD IS CONNECTED BY CAULKING OF THE CLAMP METAL (COMMERCIAL ITEM) FITTING WITH CONNECTOR SHIELD REF ④.

CONNECTOR UNIT

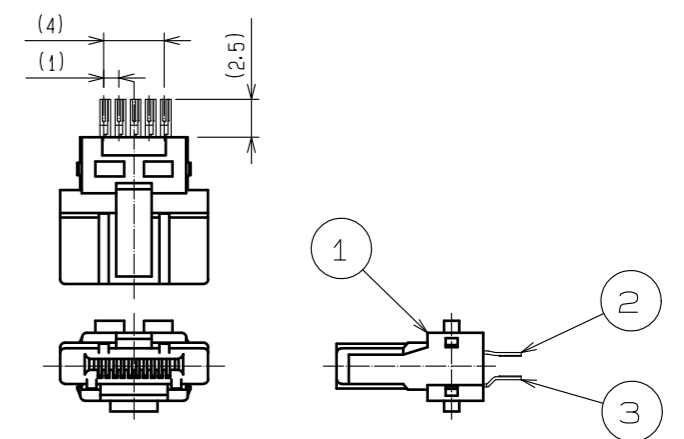

- NOTE 1 LESS THAN  $\phi 4$  mm IS PRESUMED CABLE SIZE.  
 ② CABLE SHALL BE OVERMOLDED WITH BUSHING TO FIX. USE NON-MIGRATION RESIN FOR OVERMOLDING.  
 ③ <PLATING>  
 CONTACT AREA: GOLD PLATED 0.2 $\mu$ m MIN.  
 LEAD AREA: GOLD PLATED FLASH.  
 UNDER PLATING: NICKEL PLATED 2 $\mu$ m MIN.  
 THE PRODUCT IS DELIVERED IN FOLLOWING VONDITIONS: UNIT WITH REF ② AND ③ ASSEMBLED TO REF ①, COVER WITH REF ⑧ AND ⑨ ASSEMBLED TO REF ⑥, AND REF ④, ⑤, ⑦, ⑩ DISASSEMBLED.  
 ④ REFER TO THE TECHNICAL SPECIFICATION (ETAP-E3217) FOR PACKING.

NO.	MATERIAL	FINISH	REMARKS	NO.	MATERIAL	FINISH	REMARKS
5	STAINLESS STEEL			10	STEEL		TAPPING SCREW COLOR: BLACK (TRIVALENT BLACK CHROMATE)
4	STAINLESS STEEL			9	STAINLESS STEEL		
3	COPPER ALLOY	③		8	STAINLESS STEEL		
2	COPPER ALLOY	③		7	PC		(BLACK) UL94V-0
1	PA		(BLACK) UL94V-0	6	PC		(BLACK) UL94V-0

UNITS	SCALE	COUNT	DESCRIPTION OF REVISIONS	DESIGNED	CHECKED	DATE
mm	2 : 1	1	DIS-E-00009892	KN. ICHIKAWA	KG. OKITA	20220624

APPROVED	DATE	DRAWING NO.
NM. NISHIMATSU	20151027	EDC-124278-30-00
CHECKED	DATE	PART NO.
KN. ICHIKAWA	20151027	ST40X-10S-CVR(30)
DESIGNED	DATE	CODE NO.
TS. ITO	20151027	CL0241-0029-4-30
DRAWN	DATE	
AK. AKIYAMA	20151027	