

Jul.1.2024 Copyright 2024 HIROSE ELECTRIC CO., LTD. All Rights Reserved.
 In case of consideration for using Automotive equipment / device which demand high reliability, kindly contact our sales window correspondents.

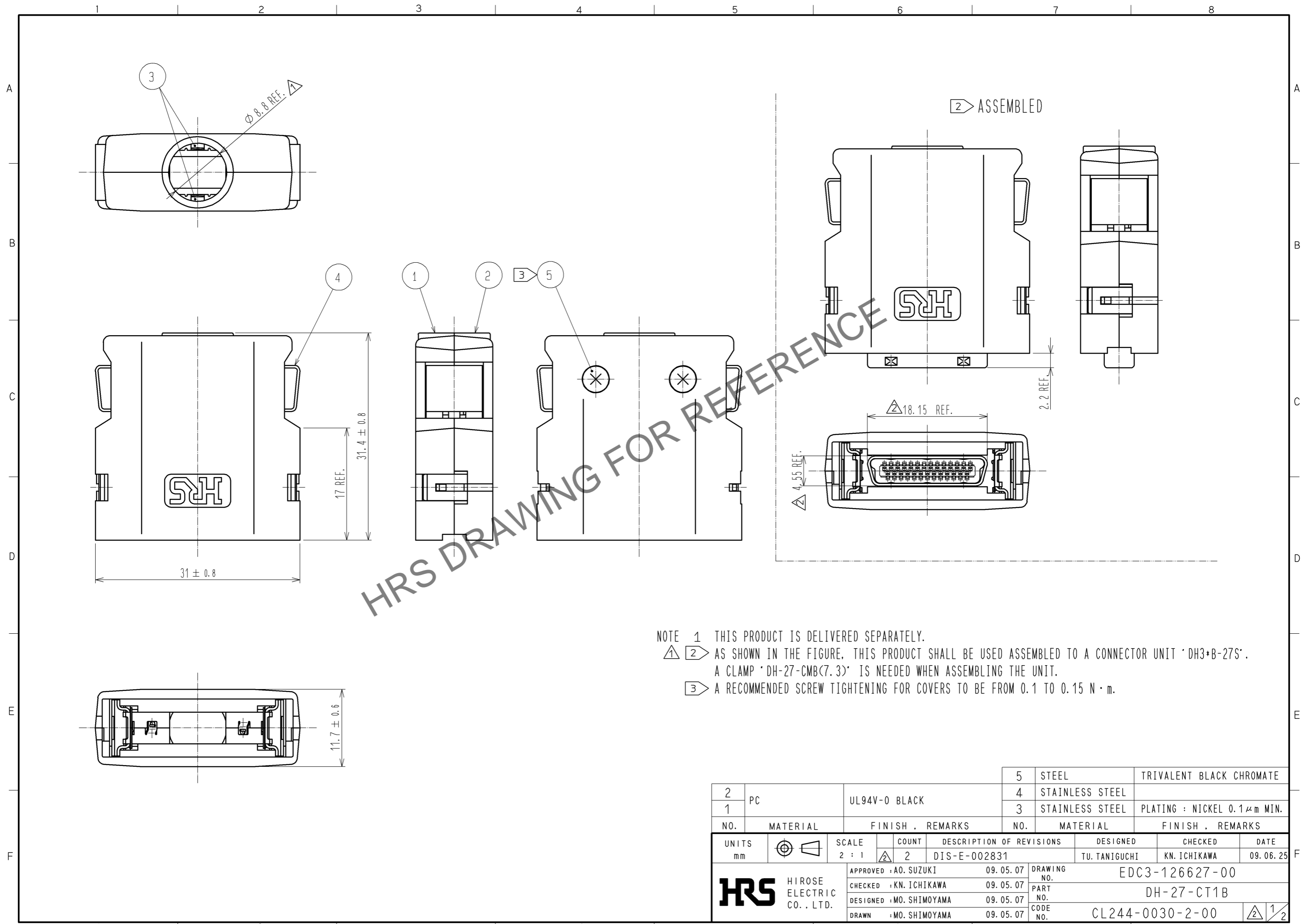

NOTE 1 THIS PRODUCT IS DELIVERED SEPARATELY.
 2 AS SHOWN IN THE FIGURE, THIS PRODUCT SHALL BE USED ASSEMBLED TO A CONNECTOR UNIT 'DH3*B-27S'.
 A CLAMP 'DH-27-CMB(7.3)' IS NEEDED WHEN ASSEMBLING THE UNIT.
 3 A RECOMMENDED SCREW TIGHTENING FOR COVERS TO BE FROM 0.1 TO 0.15 N · m.

2	PC	UL94V-0 BLACK	5	STEEL	TRIVALENT BLACK CHROMATE
1			4	STAINLESS STEEL	
			3	STAINLESS STEEL	PLATING : NICKEL 0.1 μm MIN.
NO.	MATERIAL	FINISH . REMARKS	NO.	MATERIAL	FINISH . REMARKS
UNITS mm		SCALE 2 : 1	COUNT 2	DESCRIPTION OF REVISIONS	
				DESIGNED TU. TANIGUCHI	CHECKED KN. ICHIKAWA
				DATE 09.06.25	
HRS HIROSE ELECTRIC CO., LTD.		APPROVED : A0. SUZUKI 09.05.07	DRAWING NO. EDC3-126627-00		
		CHECKED : KN. ICHIKAWA 09.05.07	PART NO. DH-27-CT1B		
		DESIGNED : MO. SHIMOYAMA 09.05.07	CODE NO. CL244-0030-2-00		
		DRAWN : MO. SHIMOYAMA 09.05.07	1/2		

Jul.1.2024 Copyright 2024 HIROSE ELECTRIC CO., LTD. All Rights Reserved.
In case of consideration for using Automotive equipment / device which demand high reliability, kindly contact our sales window correspondents.

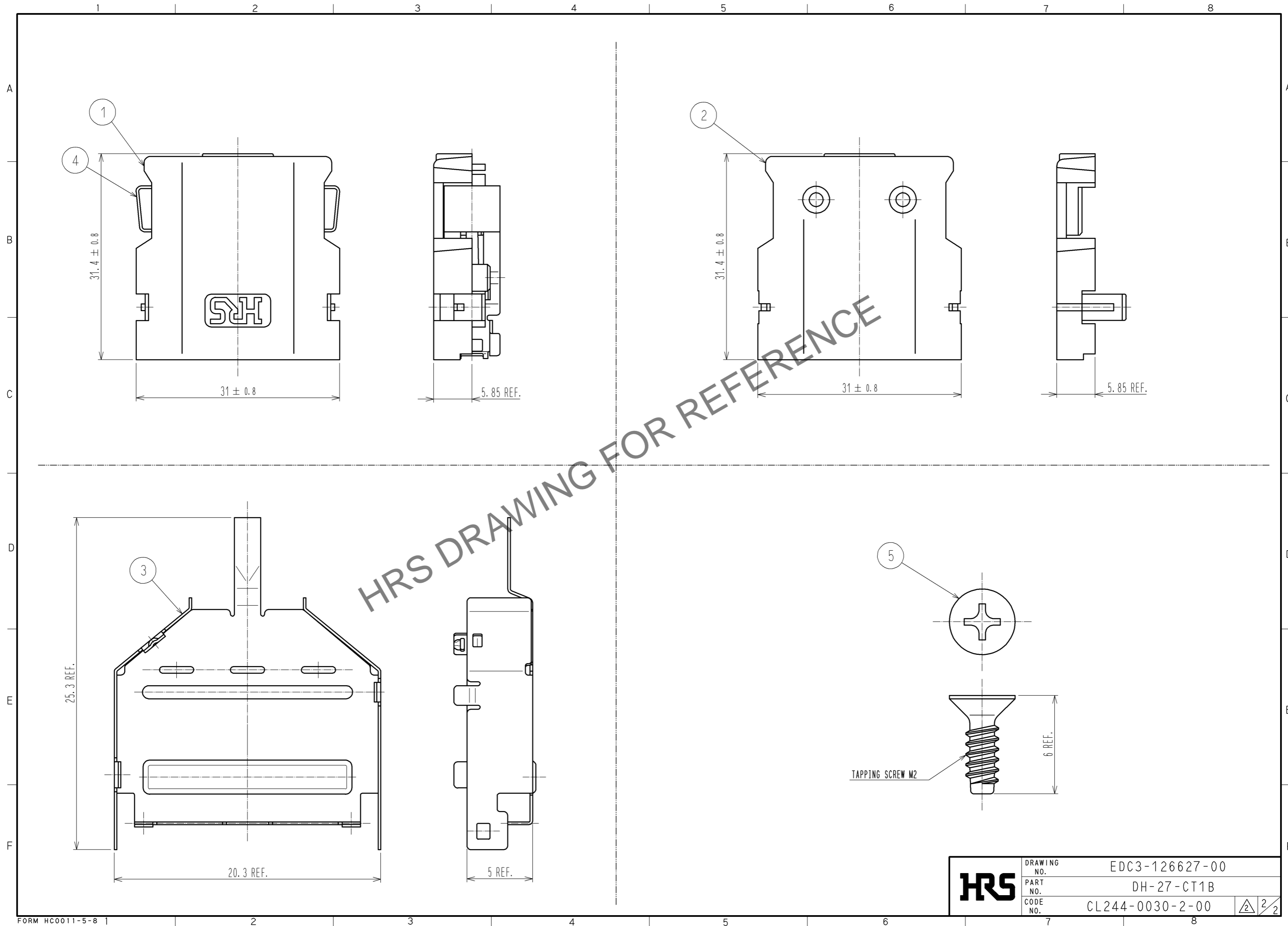

HRS	DRAWING NO.	EDC3-126627-00
	PART NO.	DH-27-CT1B
	CODE NO.	CL244-0030-2-00
		2/2