

Nov.1.2024 Copyright 2024 HIROSE ELECTRIC CO., LTD. All Rights Reserved.
 In case of consideration for using Automotive equipment / device which demand high reliability, kindly contact our sales window correspondents.

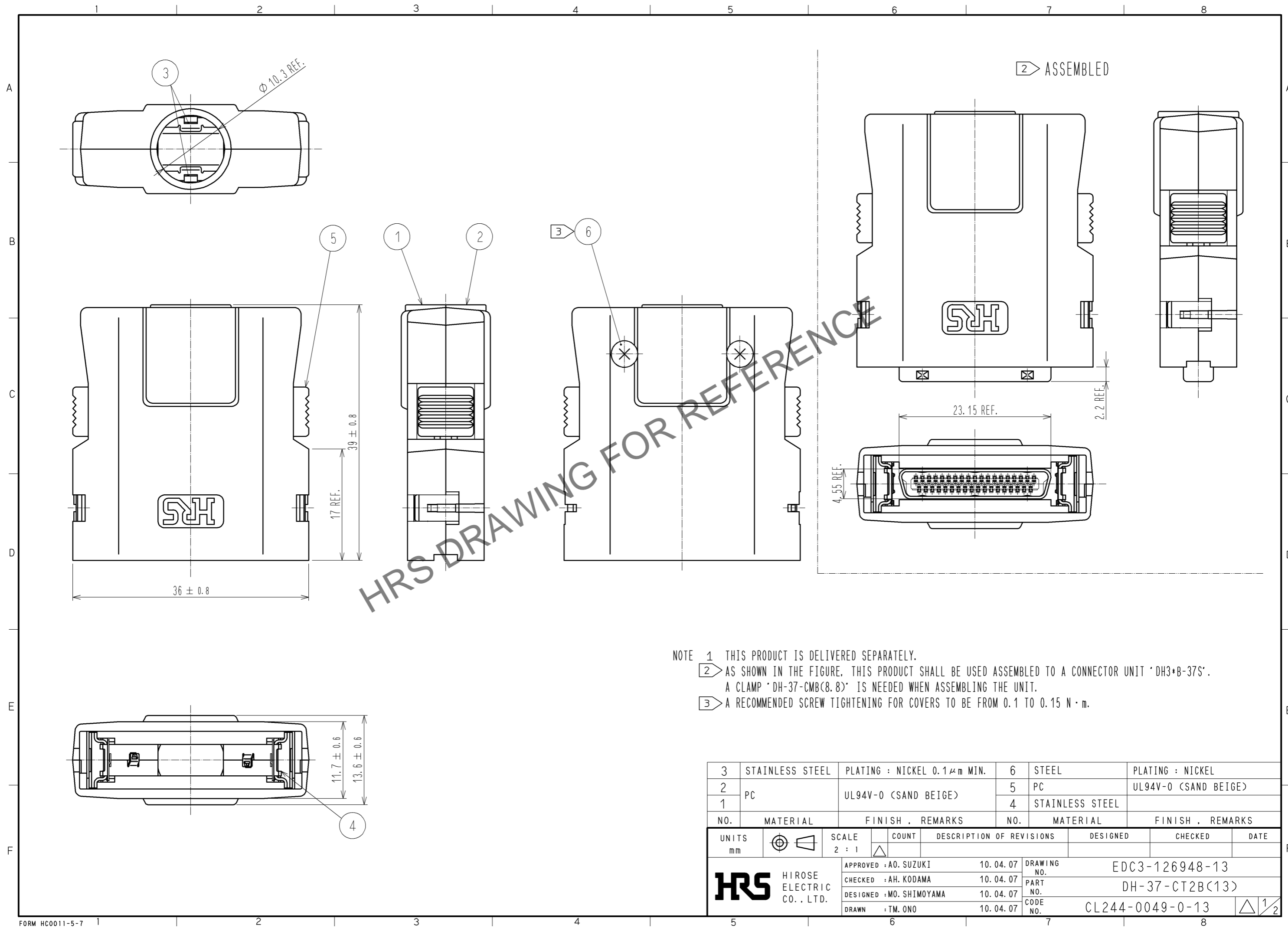

NOTE 1 THIS PRODUCT IS DELIVERED SEPARATELY.
 2 AS SHOWN IN THE FIGURE, THIS PRODUCT SHALL BE USED ASSEMBLED TO A CONNECTOR UNIT 'DH3+B-37S'.
 A CLAMP 'DH-37-CMB(8.8)' IS NEEDED WHEN ASSEMBLING THE UNIT.
 3 A RECOMMENDED SCREW TIGHTENING FOR COVERS TO BE FROM 0.1 TO 0.15 N·m.

3	STAINLESS STEEL	PLATING : NICKEL 0.1μm MIN.	6	STEEL	PLATING : NICKEL			
2	PC	UL94V-0 (SAND BEIGE)	5	PC	UL94V-0 (SAND BEIGE)			
1			4	STAINLESS STEEL				
NO.	MATERIAL	FINISH . REMARKS	NO.	MATERIAL	FINISH . REMARKS			
UNITS	mm	SCALE	2 : 1	COUNT	DESCRIPTION OF REVISIONS	DESIGNED	CHECKED	DATE
APPROVED : A0. SUZUKI		10.04.07		DRAWING NO.		EDC3-126948-13		
CHECKED : AH. KODAMA		10.04.07		PART NO.		DH-37-CT2B(13)		
DESIGNED : MO. SHIMOYAMA		10.04.07		CODE NO.		CL244-0049-0-13		
DRAWN : TM. ONO		10.04.07				1/2		

Nov.1.2024 Copyright 2024 HIROSE ELECTRIC CO., LTD. All Rights Reserved.
In case of consideration for using Automotive equipment / device which demand high reliability, kindly contact our sales window correspondents.

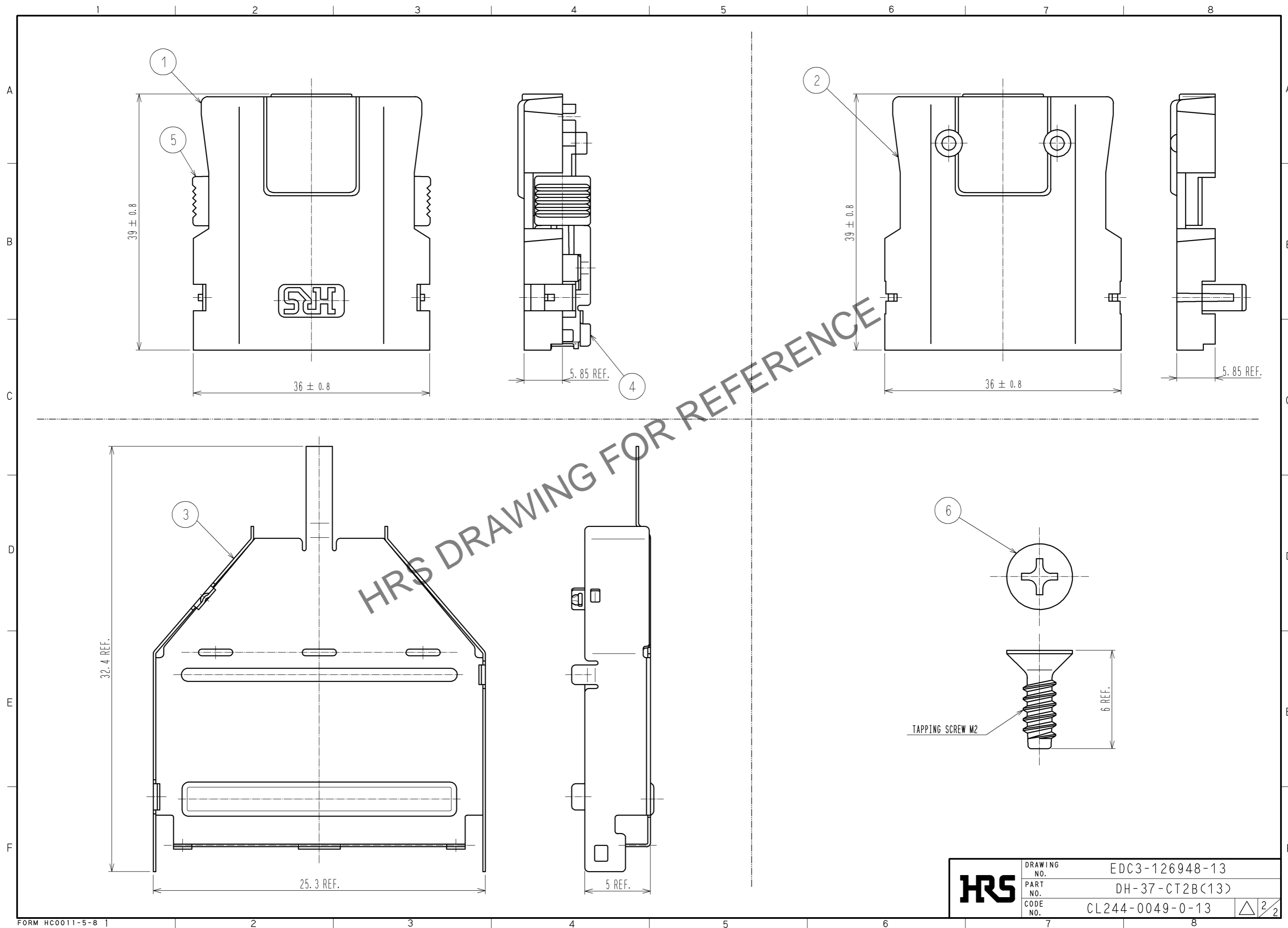

HRS	DRAWING NO.	EDC3-126948-13
	PART NO.	DH-37-CT2B(13)
	CODE NO.	CL244-0049-0-13
		\triangle 2/2