

May.1.2024 Copyright 2024 HIROSE ELECTRIC CO., LTD. All Rights Reserved.
In case of consideration for using Automotive equipment / device which demand high reliability, kindly contact our sales window correspondents.

【 Assemble tool 】 For center contact crimping : body : MIL-DTL-M22520/7-01
 For center contact crimping : positioner : BNC75-12G/CRMD (CL902-3264-0)
 For outer conductor crimping : body : MIL-DTL-M22520/5-01
 For outer conductor crimping : die : MIL-DTL-M22520/5-55

※Other products can be used when die size is 0.324 inch HEX and width 0.4 inch.

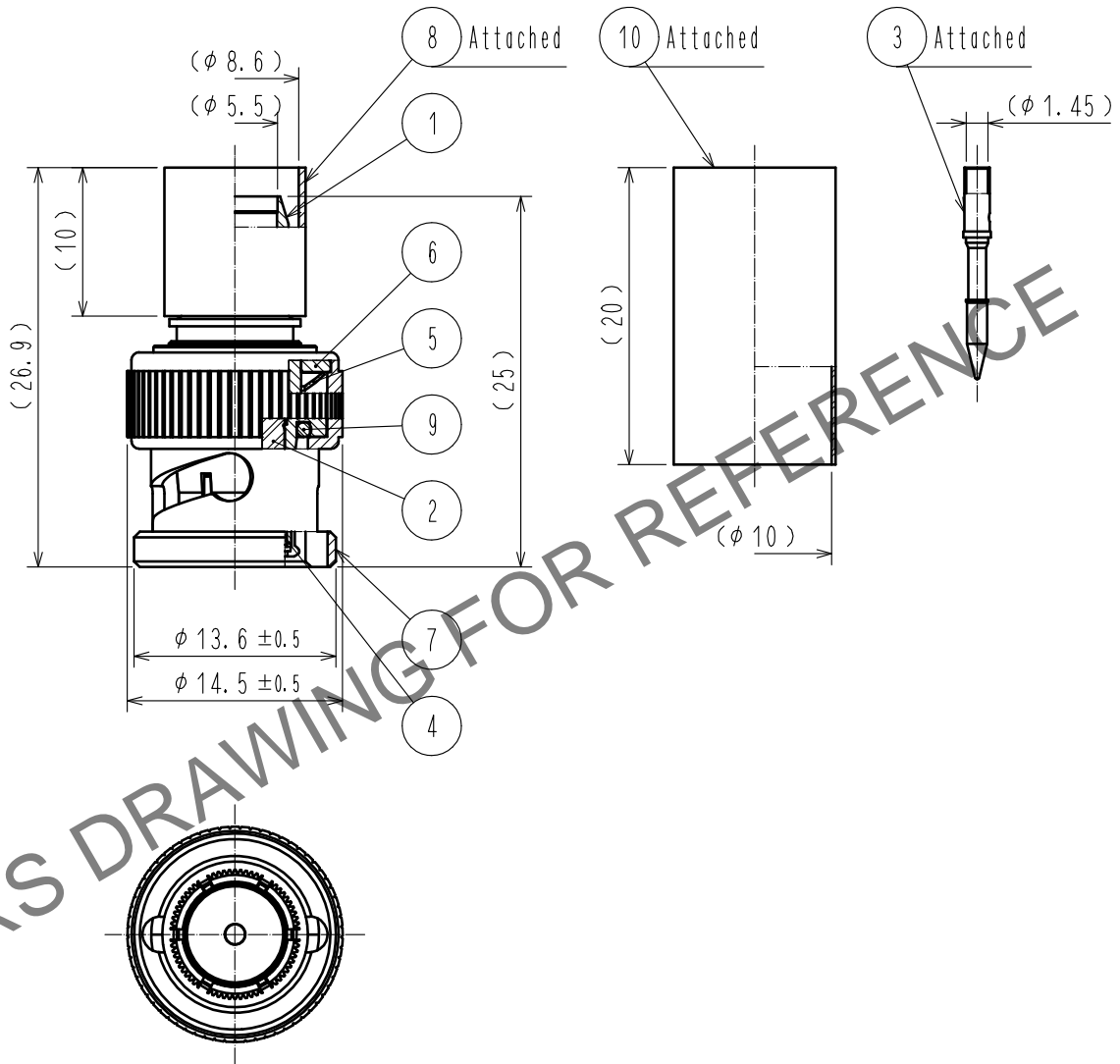

5	BERYLLIUM COPPER	SILVER PLATING	10	POLYOLEFIN	HEAT SHRINK TUBING(BLACK)
4	STAINLESS STEEL	NICKEL PLATING	9	SILICONE RUBBER	
3	BRASS	GOLD PLATING	8	COPPER ALLOY	NICKEL PLATING
2	PTFE		7	BRASS	NICKEL PLATING
1	BRASS	NICKEL PLATING	6	BRASS	NICKEL PLATING
NO.	MATERIAL	FINISH . REMARKS	NO.	MATERIAL	FINISH . REMARKS

UNITS mm		SCALE 2 : 1	COUNT 	DESCRIPTION OF REVISIONS	DESIGNED	CHECKED	DATE	
HIROSE ELECTRIC CO., LTD.		APPROVED : TO. KATAYAMA	20190520	DRAWING NO.	EDC-382240-00-01			
		CHECKED : TO. KATAYAMA	20190520	PART NO.	BNC(75)-P-5.5C-12G			
		DESIGNED : RO. YOKOYAMA	20190520	CODE NO.	CL302-0091-0-00		1	1
		DRAWN : ST. KISHI	20190520					