

Dec.1.2024 Copyright 2024 HIROSE ELECTRIC CO., LTD. All Rights Reserved.
In case of consideration for using Automotive equipment / device which demand high reliability, kindly contact our sales window correspondents.

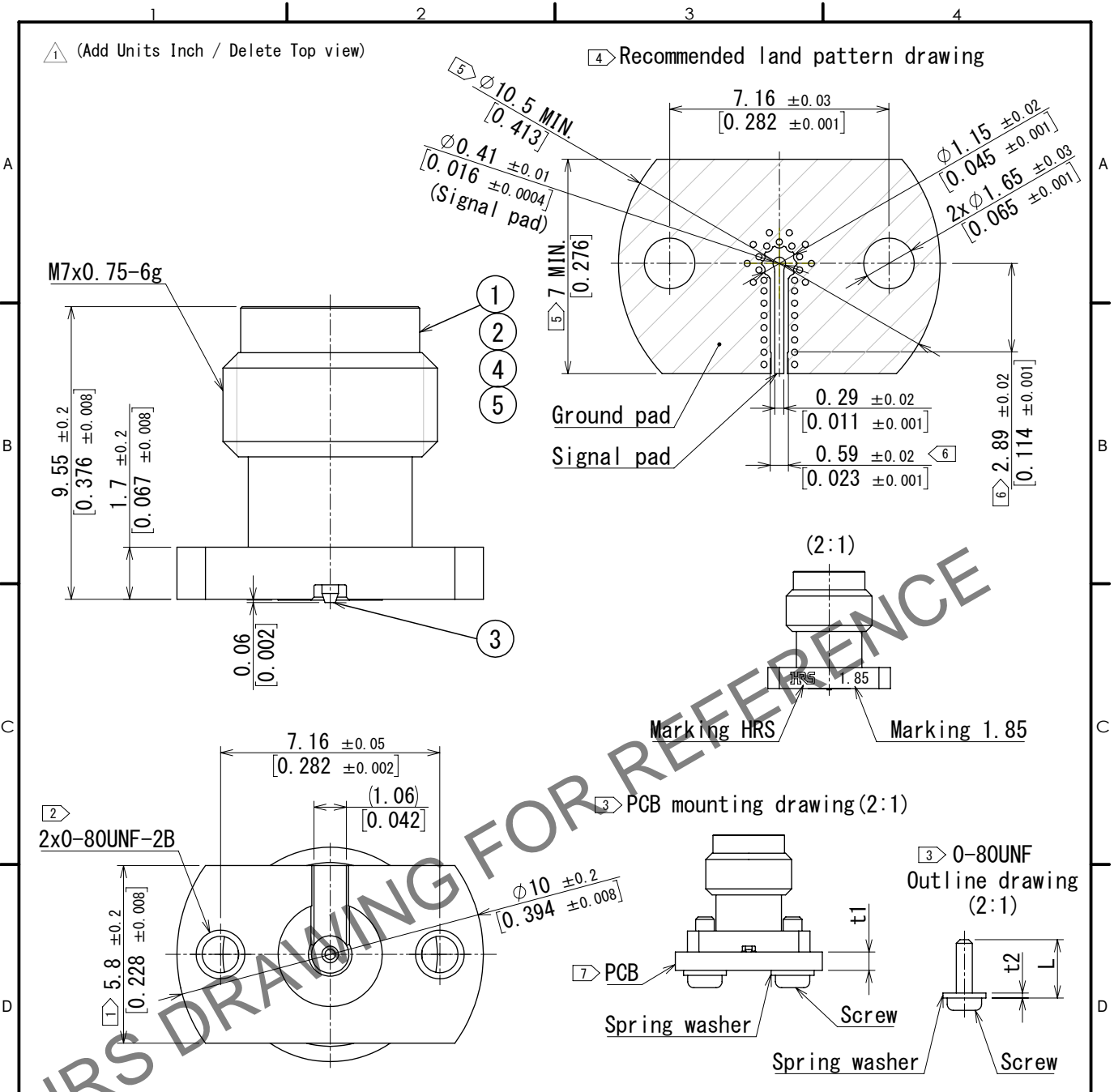

- ① Please hold the connector flange with a spanner to avoid any torque acting on the PCB when the connector is mating.
- ② 0-80UNF screws recommended tightening torque is 0.09N·m. Please tighten the screws evenly during the connector mounting to ensure stable electrical contact.
- ③ Recommended length of the screws: $L = t1(\text{PCB}) + t2(\text{spring washer}) + 2 \text{ mm} [0.08 \text{ in}]$.
- ④ PCB design is changed depending on the PCB material, thickness and stackup.
- ⑤ The solder mask prohibited area is indicated.
- ⑥ The connector is placed over this area.
- ⑦ PCB thickness $t1$ should be 0.8 mm [0.032 in] or more.
- 8. This connector is not recommended for use in actual commercial equipment.

3	BERYLLIUM COPPER	GOLD PLATING					
2	STAINLESS STEEL	PASSIVATED	5	PTFE			
1	BRASS	NICKEL PLATING	4	PEI			
NO.	MATERIAL	FINISH	REMARKS	NO.	MATERIAL	FINISH	REMARKS

UNITS mm [inch]		SCALE 5:1	COUNT 2	DESCRIPTION OF REVISIONS DIS-D-00016021	DESIGNED TS. KANEKO	CHECKED TS. NAKAGAWA	DATE 2023.06.01
HIROSE ELECTRIC CO., LTD.				APPROVED : TS. NAKAGAWA 2023.04.07 CHECKED : TS. KANEKO 2023.04.07 DESIGNED : YK. KIUCHI 2023.04.07 DRAWN : YK. KIUCHI 2023.04.07	DRAWING NO. EDC-401978-00-00 PART NO. HV-R-SR2-SA CODE NO. CL0338-0030-0-00		