

Apr.1.2024 Copyright 2024 HIROSE ELECTRIC CO., LTD. All Rights Reserved.
 In case of consideration for using Automotive equipment / device which demand high reliability, kindly contact our sales window correspondents.

| 1 | | | | | 2 | | | | | 3 | | | | | 4 | | | | |
|-------|--------------------------|--|--|--|----|------|------|-------|--------------------------|---|--|--|----|------|------|--|--|--|--|
| COUNT | DESCRIPTION OF REVISIONS | | | | BY | CHKD | DATE | COUNT | DESCRIPTION OF REVISIONS | | | | BY | CHKD | DATE | | | | |
| △ | | | | | | | | △ | | | | | | | | | | | |
| △ | | | | | | | | △ | | | | | | | | | | | |
| △ | | | | | | | | △ | | | | | | | | | | | |

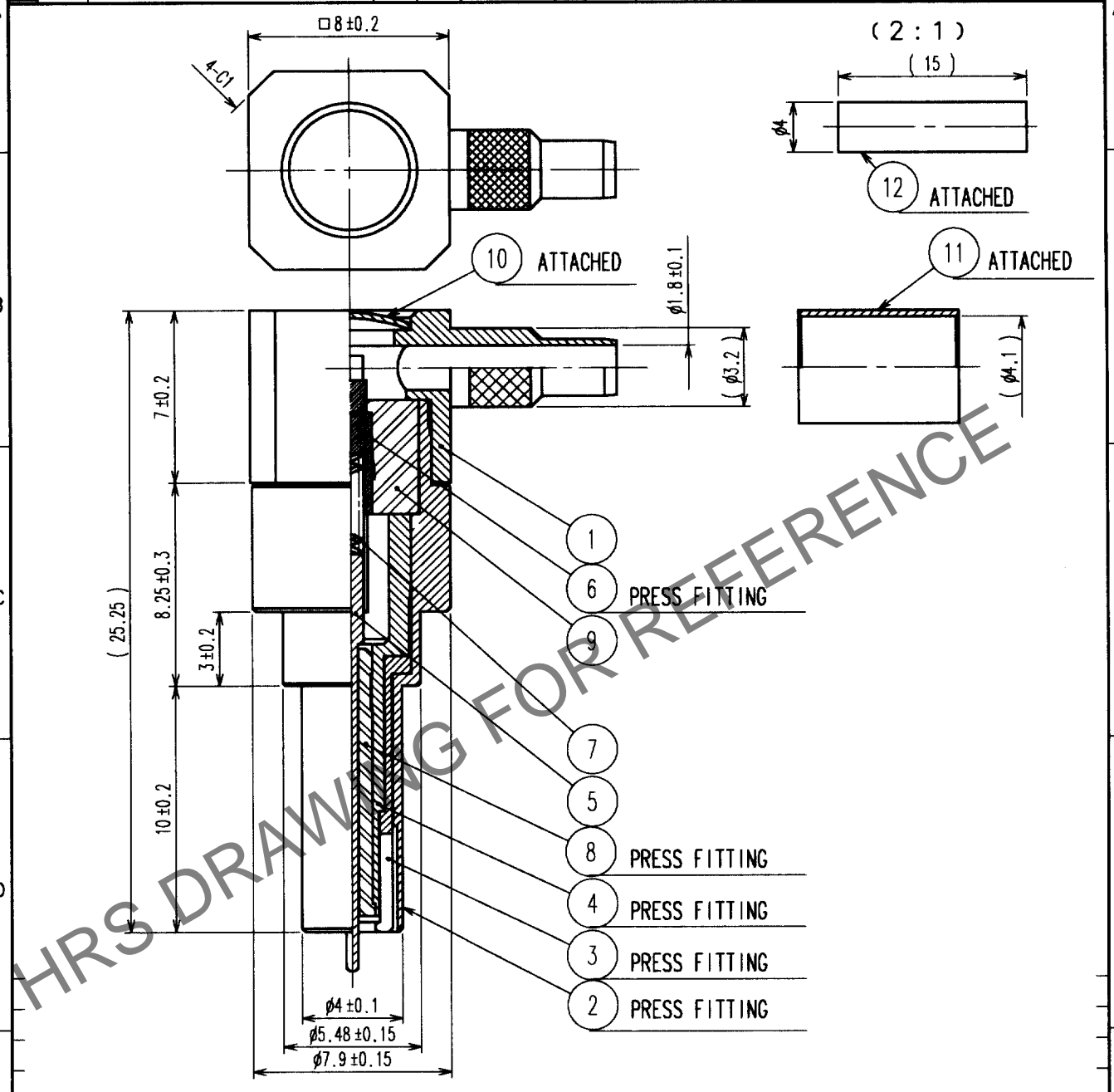

| 6 | BERYLLIUM COPPER | GOLD | 12 | POLYOLEFIN | HEAT SHRINK TUBING |
|-----|------------------|-----------------|-----|------------|--------------------|
| 5 | PHOSPHOR BRONZE | GOLD | 11 | COPPER | NICKEL |
| 4 | PHOSPHOR BRONZE | NICKEL | 10 | BRONZE | NICKEL |
| 3 | BERYLLIUM COPPER | GOLD | 9 | PTFE | |
| 2 | PHOSPHOR BRONZE | NICKEL | 8 | PTFE | |
| 1 | PHOSPHOR BRONZE | NICKEL | 7 | STAINLESS | GOLD |
| NO. | MATERIAL | FINISH, REMARKS | NO. | MATERIAL | FINISH, REMARKS |

| | | | | | |
|----------------|----------------|----------------|--------------------|------------------|----------|
| CODE NO. (OLD) | DRAWN | DESIGNED | CHECKED | APPROVED | RELEASED |
| | <i>K. Hada</i> | <i>K. Hada</i> | <i>T. Yamamoto</i> | <i>Y. Miyake</i> | |
| | 02.8.2 | 02.8.2 | 02.8.2 | 02.8.4 | |

| | | |
|-----------------------------------|---------------------------|--------------------------|
| SCALE 4 : 1 UNITS mm | DRAWING NO. | PART NO. |
| | EDC4-180289 | MS-156-C(LP)-2 |
| | HIROSE ELECTRIC CO., LTD. | CODE NO. CL358-0174-3 |

| |
|-----|
| TO |
| RFD |
| |
| |

1/1