

Jun.1.2026 Copyright 2026 HIROSE ELECTRIC CO., LTD. All Rights Reserved.  
In case of consideration for using Automotive equipment / device which demand high reliability, kindly contact our sales window correspondents.

△數 COUNT	訂正事項 DESCRIPTION OF REVISIONS	擔當 B Y	檢圖 CHKD	年月日 DATE	△數 COUNT	訂正事項 DESCRIPTION OF REVISIONS	擔當 B Y	檢圖 CHKD	年月日 DATE
△					△				
△					△				
△					△				

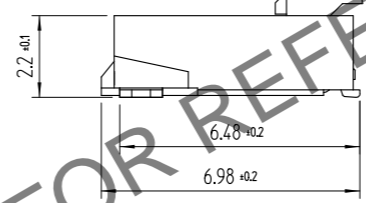
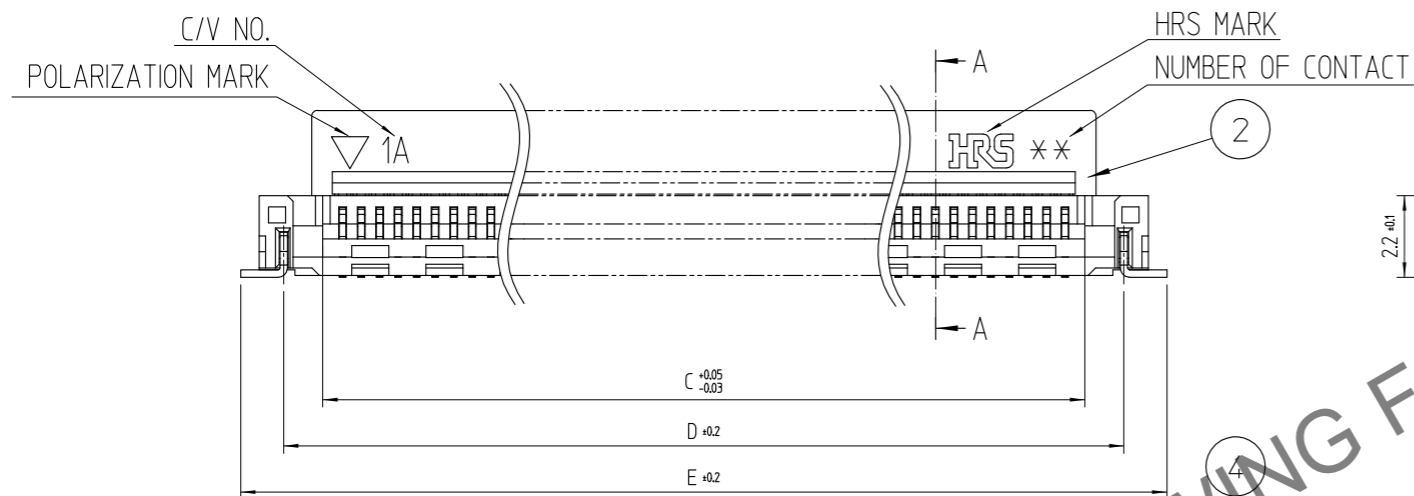
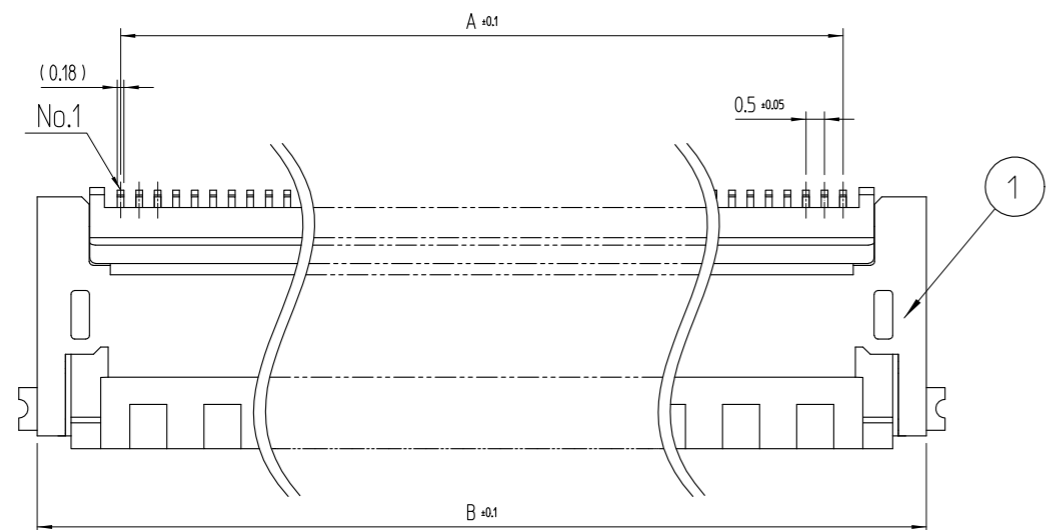

RECOMMENDED PCB LAND PATTERN (Non scale)

(RECOMMENDED METAL MASK THICKNESS : t=0.12)

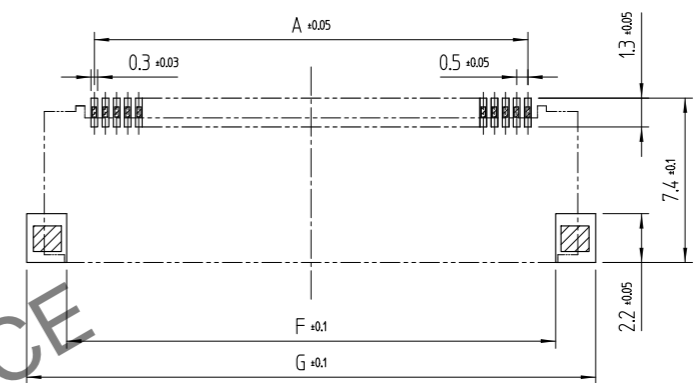

RECOMMENDED FPC/FFC (Non scale)

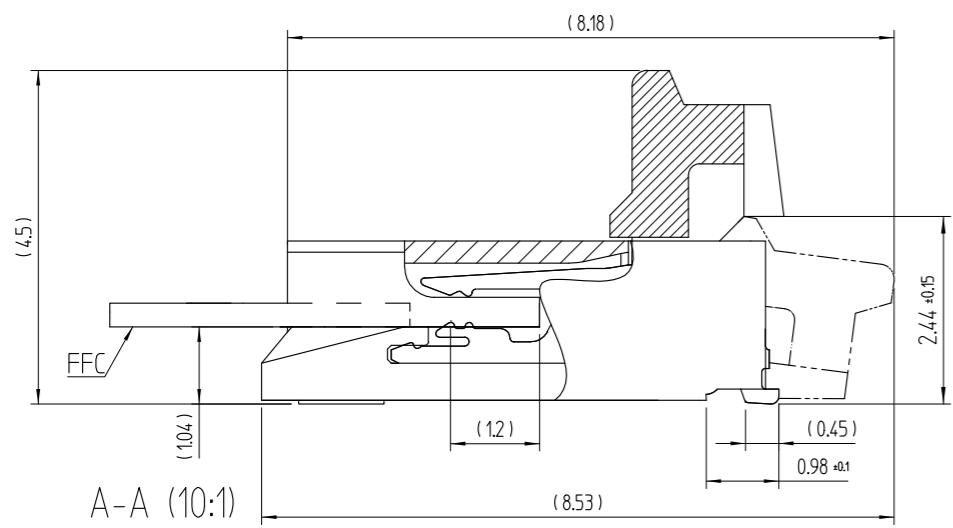
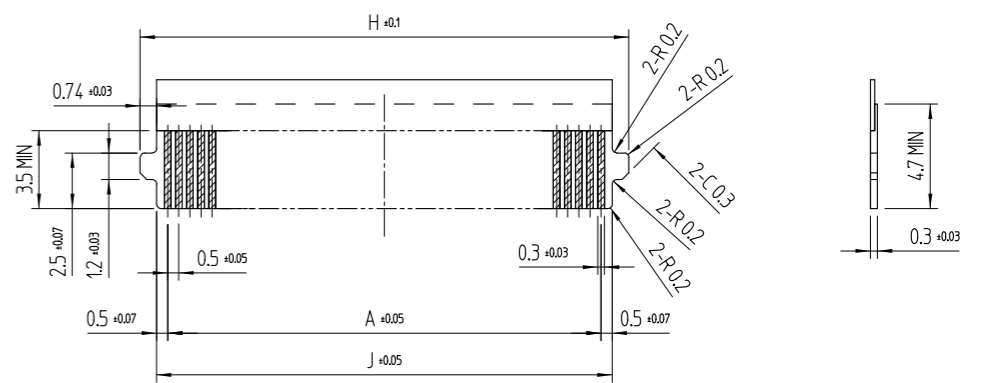

- Lead CO-PLANARITY including reinforced metal fittings shall be 0.1MAX.
- To be delivered with tape and reel packages.

2	LCP	UL94V-0, BLACK	4	COPPER ALLOY	TIN PLATING 1μm MIN, OVER NICKEL 1μm MIN
1	LCP	UL94V-0, BLACK	3	COPPER ALLOY	(CONTACT AREA) GOLD 0.03μm MIN, OVER NICKEL 1μm MIN (LEAD) GOLD 0.03μm MIN, OVER NICKEL 1μm MIN (OTHER) NICKEL PLATING 1μm MIN
NO.	MATERIAL	FINISH,REMARKS	NO.	MATERIAL	FINISH,REMARKS
CODE NO. (OLD)			DRAWN		
			DESIGNED		
			CHECKED		
			APPROVED		
			RELEASED		
SCALE 5:1		DRAWING NO. EDC3-632297	PART NO. TF46-**S-0.5SH(800)		
UNITS mm		<b>HRS</b> HIROSE KOREA CO.,LTD.	CODE NO.		
					1/5

HRS DRAWING FOR REFERENCE

Jun.1.2026 Copyright 2026 HIROSE ELECTRIC CO., LTD. All Rights Reserved.  
In case of consideration for using Automotive equipment / device which demand high reliability, kindly contact our sales window correspondents.

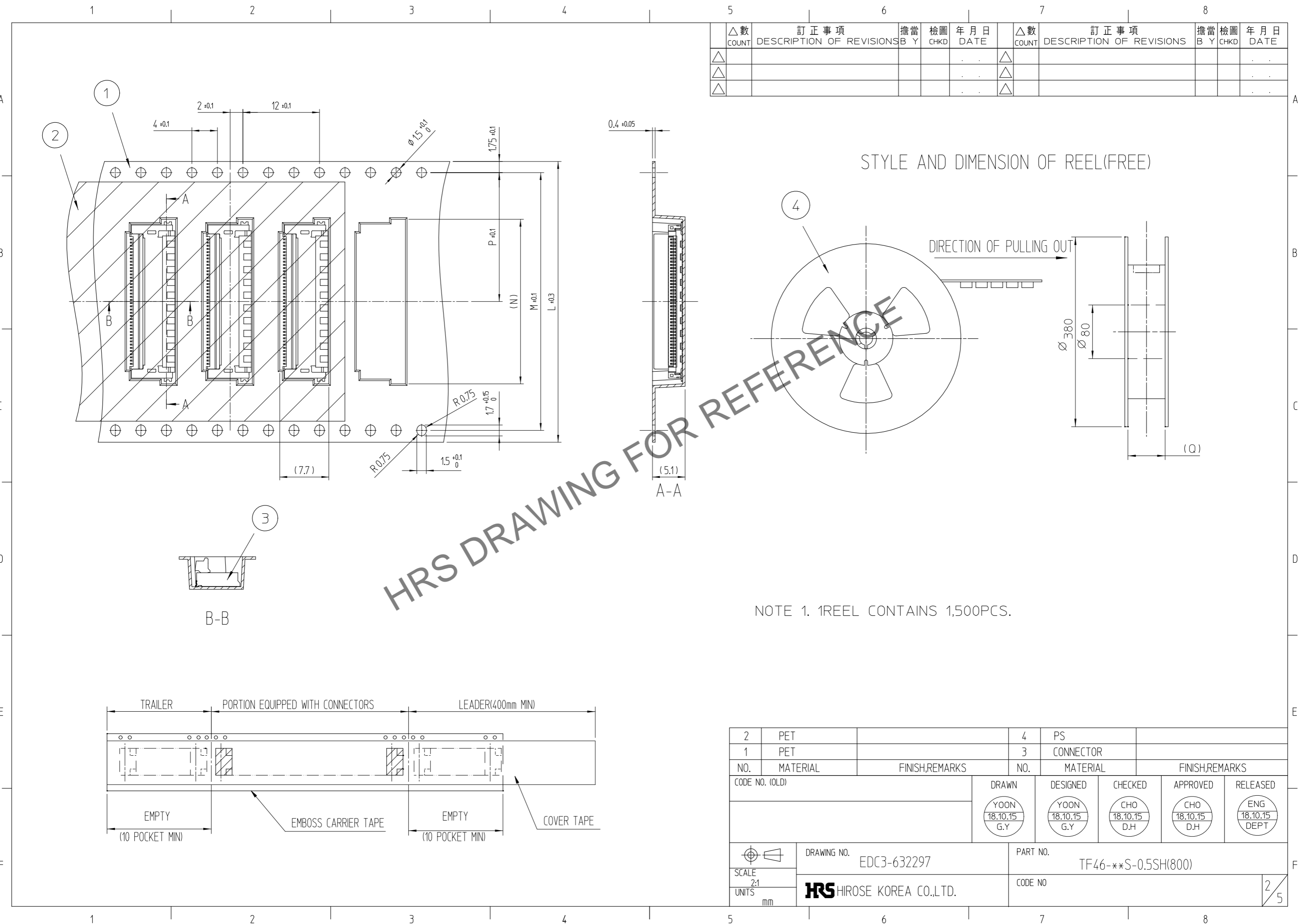

△數 COUNT	訂正事項 DESCRIPTION OF REVISIONS	擔當 B Y	檢圖 CHKD	年月日 DATE	△數 COUNT	訂正事項 DESCRIPTION OF REVISIONS	擔當 B Y	檢圖 CHKD	年月日 DATE
△					△				
△					△				
△					△				

HRS DRAWING FOR REFERENCE

NOTE 1. 1REEL CONTAINS 1,500PCS.

2	PET		4	PS	
1	PET		3	CONNECTOR	
NO.	MATERIAL	FINISH,REMARKS	NO.	MATERIAL	FINISH,REMARKS
CODE NO. (OLD)			DRAWN	DESIGNED	CHECKED
			YOUN 18.10.15 G.Y	YOUN 18.10.15 G.Y	CHO 18.10.15 D.H
			APPROVED		RELEASED
			CHO 18.10.15 D.H		ENG 18.10.15 DEPT
DRAWING NO. EDC3-632297			PART NO. TF46-**S-0.5SH(800)		
SCALE 2:1			CODE NO.		
UNITS mm			HRS HIROSE KOREA CO.,LTD.		
					2/5

Jun.1.2026 Copyright 2026 HIROSE ELECTRIC CO., LTD. All Rights Reserved.  
In case of consideration for using Automotive equipment / device which demand high reliability, kindly contact our sales window correspondents.

																△數	訂正事項			擔當	檢圖	年月日	△數	訂正事項			擔當	檢圖	年月日		
																COUNT	DESCRIPTION OF REVISIONS			B	Y	CHKD	DATE	COUNT	DESCRIPTION OF REVISIONS			B	Y	CHKD	DATE
																△							△								
																△							△								
																△							△								







  

PART NUMBER	NUMBER OF CONTACTS	DIMENSION OF CONNECTOR, FPC, FFC, PCB LAND, METAL MASK										DIMENSION OF PACKING				
		A	B	C	D	E	F	G	H	J	L	M	N	P	Q	
TF46-40S-0.5SH(800)	40S	19.5	24	20.57	22.68	25	22	25.6	21.98	20.5	44	40.4	25.8	20.2	44.5	
TF46-60S-0.5SH(800)	60S	29.5	34	30.57	32.68	35	32	35.6	31.98	30.5	56	52.4	35.8	26.2	56.5	

HRS DRAWING FOR REFERENCE

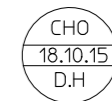
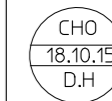
NO.		MATERIAL		FINISH,REMARKS		NO.		MATERIAL		FINISH,REMARKS					
CODE NO. (OLD)						DRAWN		DESIGNED		CHECKED		APPROVED		RELEASED	
						 YOON 18.10.15 G.Y.		 YOON 18.10.15 G.Y.		 CHO 18.10.15 D.H.		 CHO 18.10.15 D.H.		 ENG 18.10.15 DEPT	
		DRAWING NO. EDC3-632297						PART NO. TF46-**S-0.5SH(800)							
SCALE 1:1		 HIROSE KOREA CO.,LTD.						CODE NO.						3/5	
UNITS mm															

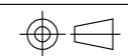
This connector features small, thin and back flip design, requiring delicate and careful handling.  
Read through the instructions shown below and handle the connector properly.

## [Operation and Precautions]

### 1. Initial condition

Actuator does not have to be operated before inserting FPC as the connector is delivered with the actuator opened. [See Fig. 1]

[Caution]

- Do not close the actuator before inserting FPC
- Closing the actuator without FPC could make the contact gap smaller, which could increase the FPC insertion force. [See Fig. 2]

[Fig. 1]

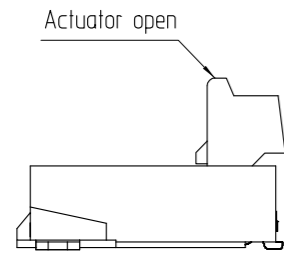

- Open when delivered -

[Fig. 2]

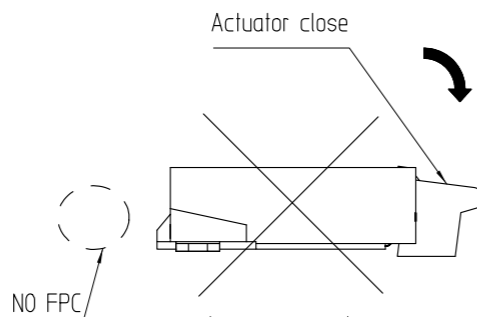

- Improper operation -

### 2. How to insert FPC

Insert the FPC into the connector opening horizontally to the board plane.  
Insert it properly to the very end.

[Caution]

- Insert the FPC with the actuator opened. [See Fig. 3, Fig. 4]
- Twisting the FPC to up and down, right and left or an angle could cause contact deformation and contact failure.

[Fig. 3]

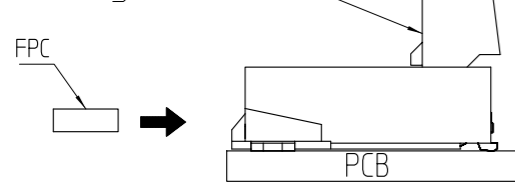

- Proper FPC insertion -

[Fig. 4]

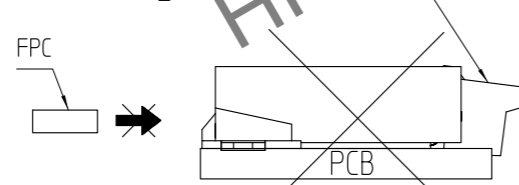

- Improper FPC insertion -

### 3. How to lock

Apply load to rotate the actuator by 97.2 degree after inserting the FPC. [See Fig. 5]

[Fig. 5]

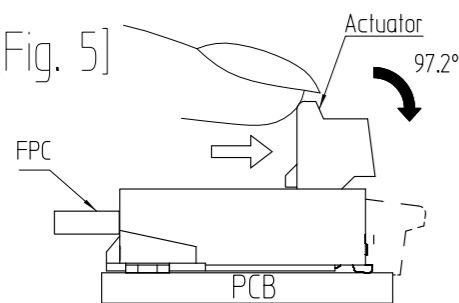

- Proper operation -

[Fig. 6]

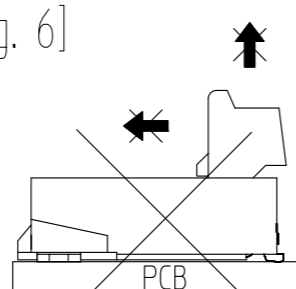

- Improper operation -

[Caution]

- The actuator rotates around the rotational axis. [See Fig. 7]
- Do not rotate the actuator to the counter direction.
- Do not pitch or pick the actuator to lift. Otherwise, it may break. [See Fig. 6]
- Apply load to the mid-point on the actuator to rotate it. [See Fig. 8]
- Do not apply excess force to the housing during the operation.

[Prohibited acts]

Do not operate the side end of the actuator, or it may twist the actuator and cause half mating.

- Please operate both ends at the same time when you cannot operate the vicinity of the center part.

[Actuator movable range] (Side view)

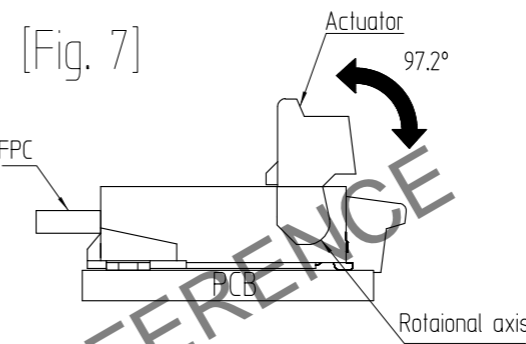

4. How to remove FPC (How to unlock)

Slowly flip up the actuator to release the lock and remove the FPC

[Caution]

- The actuator is opened up to the movable limit, 97.2 degree.
- Do not open the actuator beyond the specified degree or apply excess force to the actuator. [See Fig. 9]
- To open the actuator operate at the mid-point of the actuator. [See Fig. 8]
- Please note that the connector is back flip style connector, and the opening for FPC insertion and the actuator face the opposite direction. Do not try to lift the actuator at the FPC insertion opening side. [See Fig. 10]

[Prohibited acts]

Do not lift up the side end of the actuator, or it may twist the actuator and cause breakage.

- Please operate both ends at the same time when you cannot operate the vicinity of the center part.

[Prohibited acts]

Do not pull out the FPC with the actuator locked.  
When FPC is pulled out with the actuator locked, it cause the contact deformation and contact failure.

[Actuator operation area (lock and release)] (Top view)

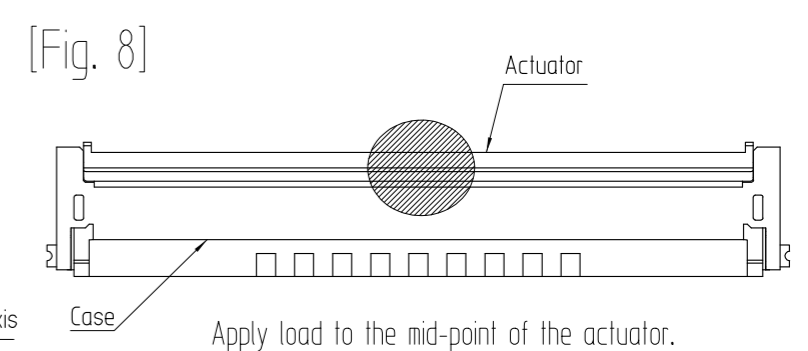

[Fig. 9]

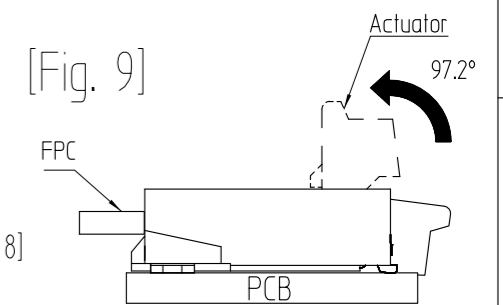

- Proper operation -

[Fig. 10]

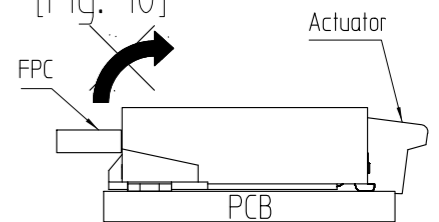

- Improper operation -

INSTRUCTION MANUAL <1>

DRAWING NO. EDC3-632297	PART NO. TF46-**S-0.5SH(800)
<b>HRS</b> HIROSE KOREA CO.,LTD.	CODE NO. 4/5

This connector features small, thin and back flip design, requiring delicate and careful handling. Read through the instructions shown below and handle the connector properly.

### [ Instructions for mounting on the board ]

#### 1. Warp of board

Minimize warp of the board as much as possible.

Lead co-planarity including reinforced metal fittings is 0.1 mm or less.

Too much warp of the board may result in a soldering failure.

#### 2. Load to connector

Do not apply mechanical stress to the connector before mounting on the board.

Otherwise, the connector may be broken.

Do not insert the FPC or operate the connector before mounting.

#### 3. Load to board

- Splitting a large board into several pieces

- Screwing the board

Avoid the handling described above so that no force is applied on the board during the assembly process

Otherwise, the connector may become defective.

#### 4. Reflow temperature profile

Apply reflow temperature profile within the specified conditions.

In individual applications, the actual temperature may vary, depending on solder paste type, volume/thickness and board size/thickness.

Consult your solder paste and equipment manufacturer for specific recommendations.

#### 5.Amount of bend of board

The bend of a 100mm wide board should be 1 mm or less. [See Fig. 11]

[Fig. 11] The bend of board could apply stress on the connector and it may become defective

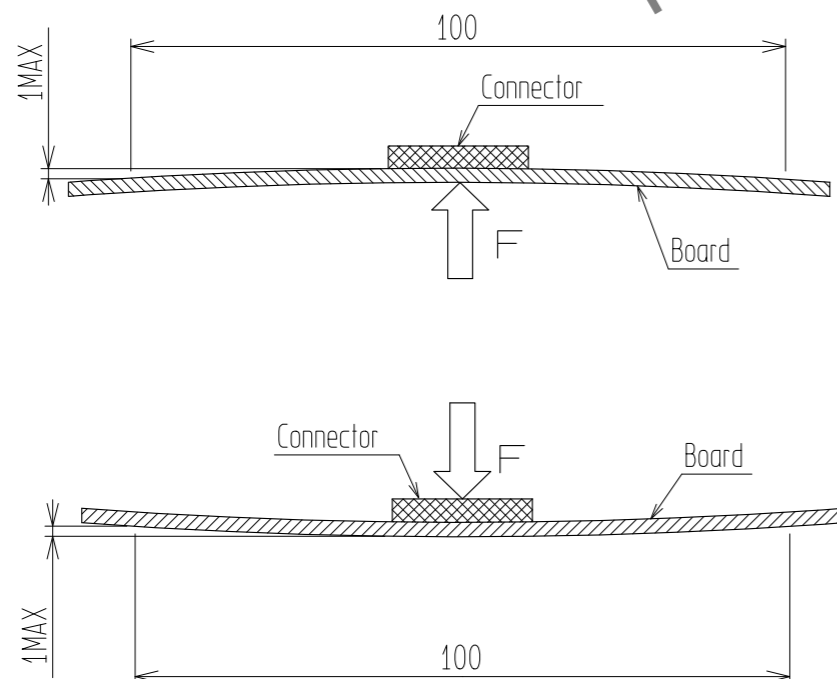

### [ Precautions for design ]

1. During FPC wiring, ensure that stress is not applied directly to the connector

Do not bend the FPC excessively near the connector during use, or it may cause contact failure or FPC breakage.

Stabilizing the FPC is recommended.

2. Keep a sufficient FPC insertion space in the stage of the layout in order to avoid incorrect FPC insertion

Appropriate FPC length and component layout are recommended for assembly ease.

Too short FPC length makes assembly difficulty.

3. Follow the recommended PCB layout, FPC design and the metal mask opening design.

4. Make adjustments with the FPC manufacturer for FPC bending performance and wire breakage.

5. Keep spaces for the actuator movement and its operation for PCB design and component layout.

### [ Other instructions ]

1. Instructions on manual soldering

Follow the instructions shown below when soldering the connector manually during repair work, etc.

#### [ Prohibited acts ]

1. Do not perform manual soldering with the FPC inserted into the connector.

2. Do not heat the connector excessively.

Be very careful not to let the soldering iron contact any parts other than connector leads.

Otherwise, the connector may be deformed or melt.

3. Do not apply excessive solder (or flux).

If excessive solder (or flux) is applied on the terminals, solder or flux may adhere to the contacts or rotating parts of the actuator, resulting in poor contact or a rotation failure of the actuator.

Supplying excessive solder to the metal fitting may hinder actuator rotation.

resulting in breakage of the connector.

INSTRUCTION MANUAL <2>

DRAWING NO. EDC3-632297	PART NO. TF46-**S-0.5SH(800)
<b>HRS</b> HIROSE KOREA CO.,LTD.	CODE NO. 5/5