

In case of consideration for using Automotive equipment / device which demand high reliability, kindly contact our sales window

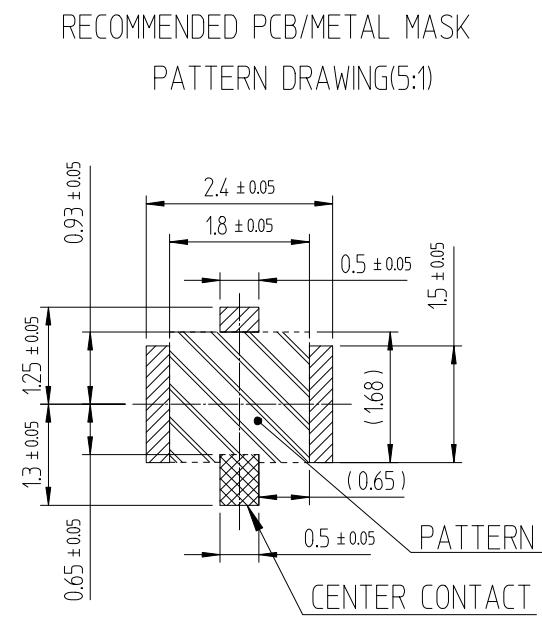

△数 COUNT	訂正事項 DESCRIPTION OF REVISIONS	擔當 B	檢圖 CHKD	年月日 DATE	△数 COUNT	訂正事項 DESCRIPTION OF REVISIONS	擔當 B	檢圖 CHKD	年月日 DATE
△				..	△				..
△				..	△				..
△				..	△				..

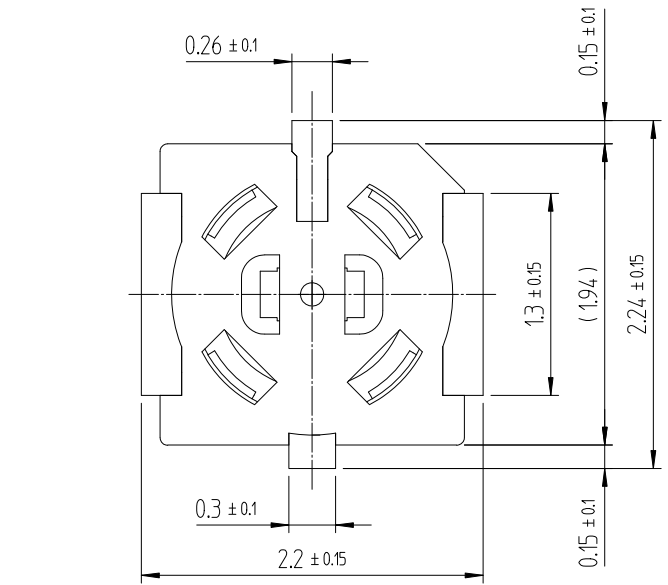
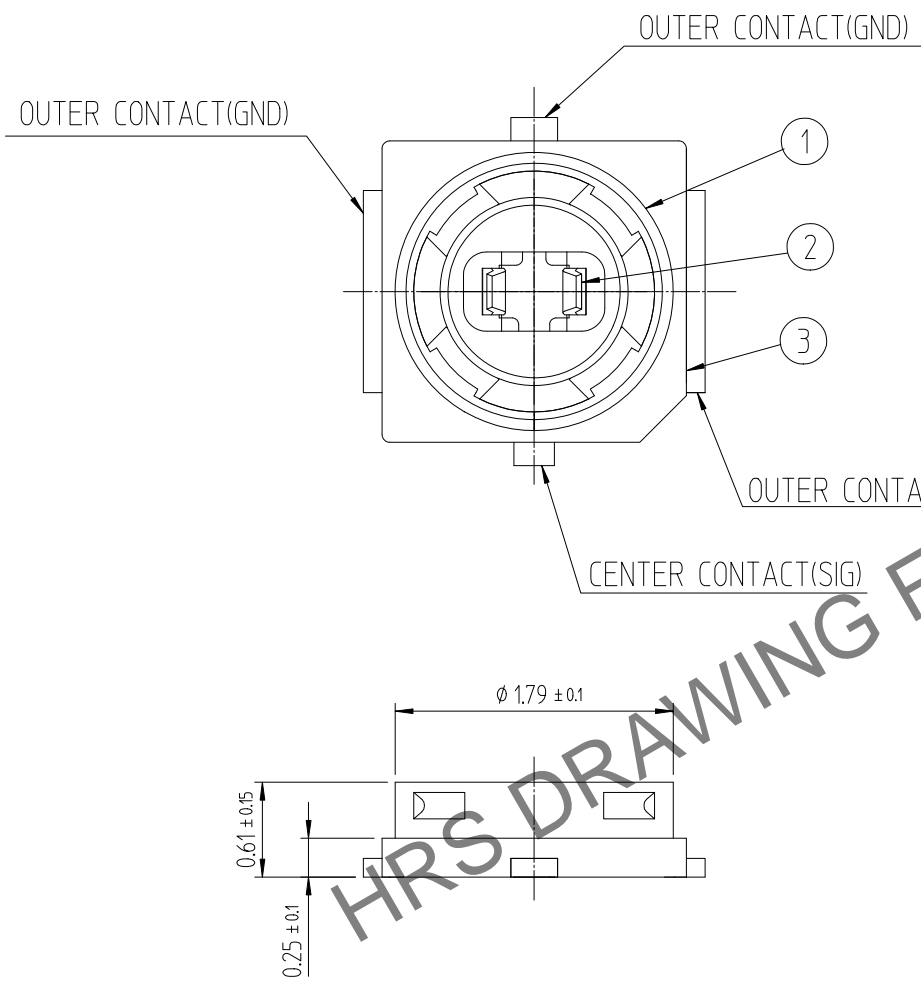
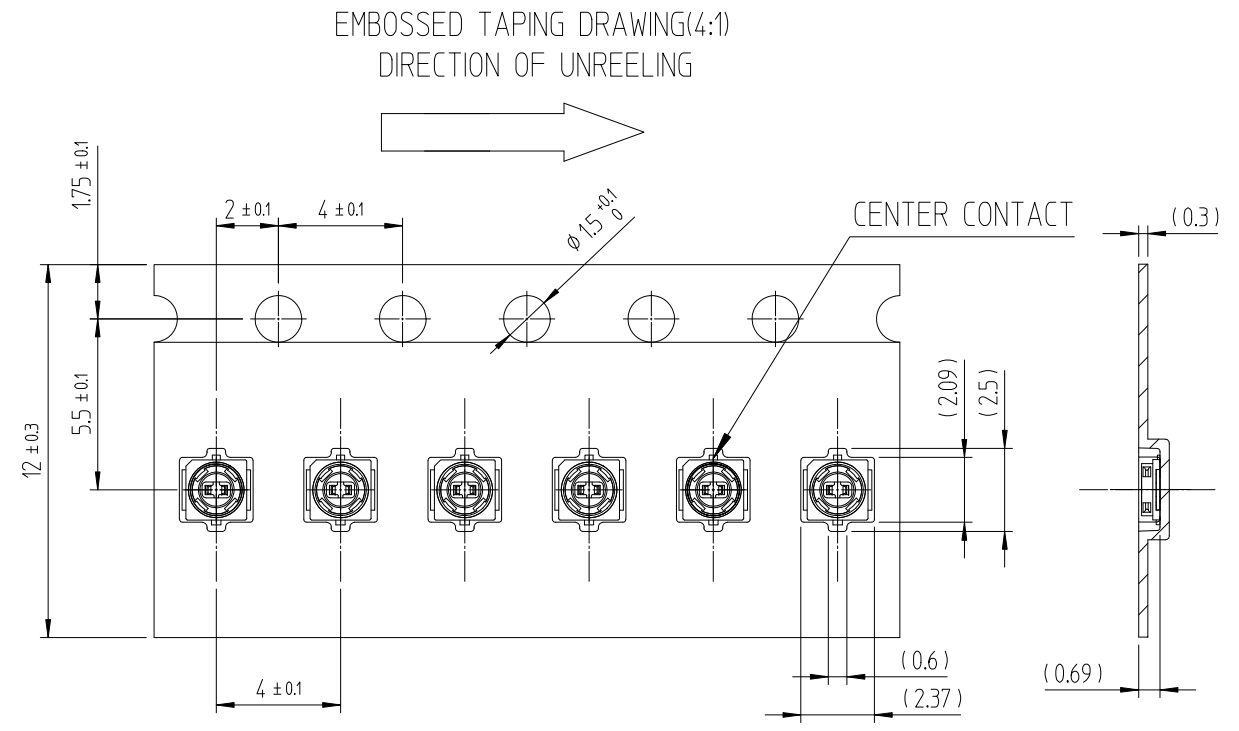

REEL DRAWING (SCALE FREE)

RECOMMENDED REFLOW TEMPERATURE PROFILE

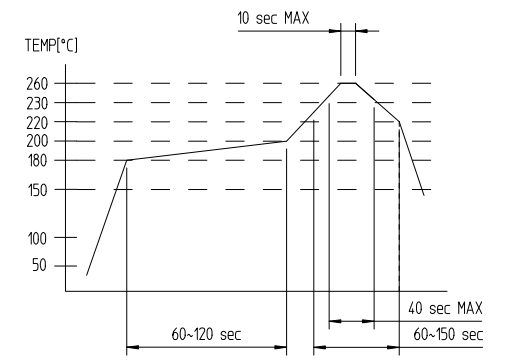
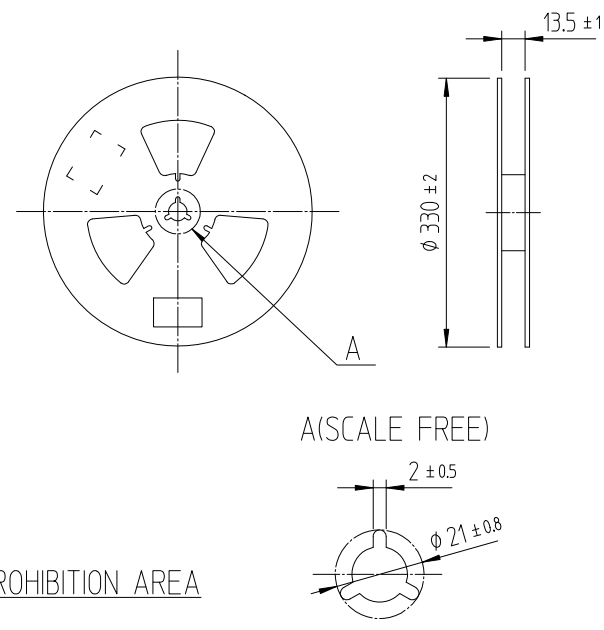

NOTE  
MOUNTING TEMPERATURE PROFILE VARIES ACCORDING  
TO BOARD SIZE, SOLDER TYPE APPLIED AND SOLDER THICKNESS  
- METAL MASK THICKNESS : 0.1mm

RoHS COMPLIANT, Halogen Free

- NOTES :
- The quantity of K.FL2-PR-SMT09 is 10000 connectors per reel.
  - Lead co-planarity shall be 0.1max.
  - For the possibility of breakage or deformation do not mate this connector with partner, K.FL2-R-SMT-1 before mounting on pc board.
- 4 Please contact us in case you will make different settings from our recommendation.

1	PHOSPHOR BRONZE	UNDER PLATING: NICKEL OVER PLATING: GOLD	3	LCP	<BLACK>, UL94V-0
2	PHOSPHOR BRONZE	UNDER PLATING: NICKEL OVER PLATING: GOLD	2	PHOSPHOR BRONZE	UNDER PLATING: NICKEL OVER PLATING: GOLD
NO. MATERIAL		FINISH,REMARKS		FINISH,REMARKS	
CODE NO. (OLD)			DRAWN	DESIGNED	CHECKED
			W.Y.AHN 19.01.25	W.Y.AHN 19.01.25	H.S.KIM 19.01.25
			APPROVED	RELEASED	ENG 19.01.25 DEPT
			H.S.KIM 19.01.25		
DRAWING NO. EDC3-632121-80			PART NO. K.FL2-PR-SMT09 (800)		
SCALE 20:1			CODE NO CL6345-0056-0-800		
UNITS mm			HRS HIROSE KOREA CO.,LTD.		
					1/2

□ MOUNTING PRECAUTIONS

a. FPC MOUNTING

FPC must have suitable stiffener to prevent peeling of the solder joints during mating/unmating.  
We recommend the FPC to be supported with the reinforcement.

b. MULTI-CONNECTOR PLACEMENT

When mounting on a solid PCB on both sides do not place more than one connector on each side.  
When mounting one side on a rigid PCB and other on the flexible printed circuit several connectors can be mounted on the rigid side. The FPC must have slats between each of the connectors to allow alignment with each corresponding connector.

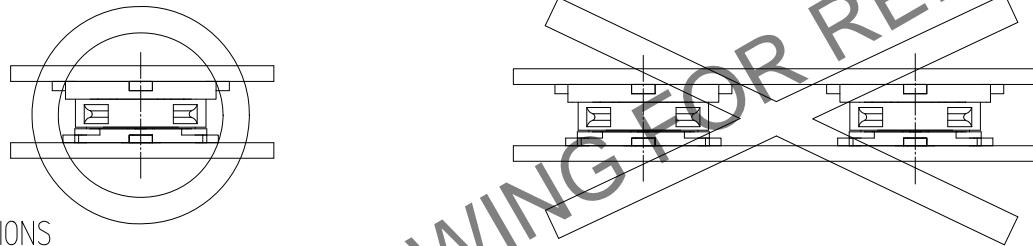

□ MATING PRECAUTIONS

Connectors must be mated by hand only. Application of excessive forces may damage the connectors.

● MATING PROCEDURES

1) Align mount plug (K.FL2-PR-SMT09) and receptacle (K.FL2-R-SMT-1) by slight touch as shown on fig. 1.

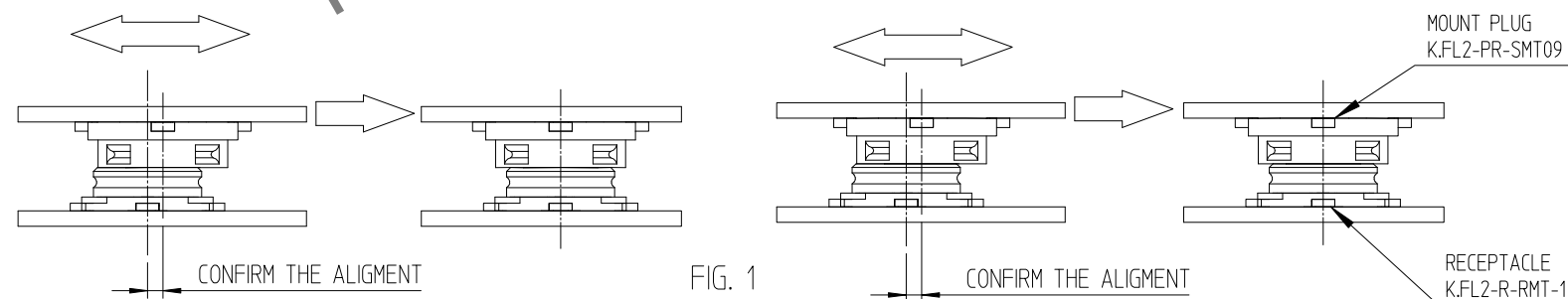

2) Confirm the alignment by applying slight even pressure to the mount plug (K.FL2-PR-SMT09) partially inserting it in the mount receptacle (K.FL2-R-SMT-1), as shown in fig. 2. The plug should not move sideways or be slanted.

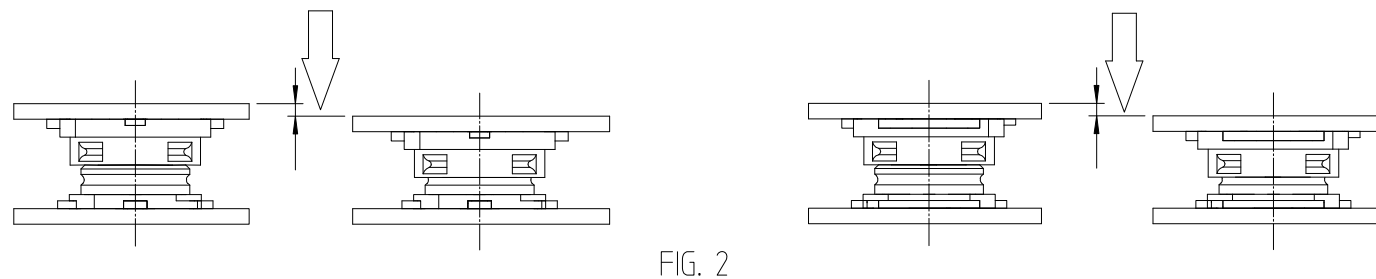

3) Push-down on the mount plug (K.FL2-PR-SMT09) until it is fully inserted, confirming it with a tactile 'CLICK'

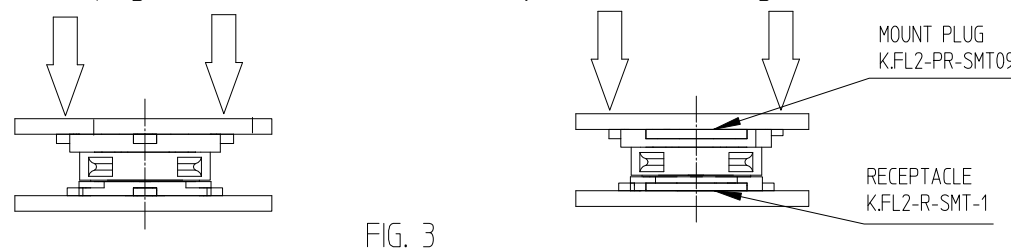

4) When mating was not possible. Please use it after confirming that a plug receptacle female contact by the transformation or the mold part does not have transformation before just using a plug receptacle.

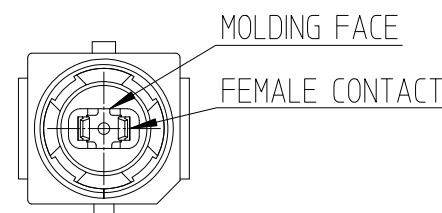

□ UNMATING PRECAUTIONS

Unmate by applying even vertical force to the mount plug (K.FL2-PR-SMT09) as shown on fig. 4.  
Do not rock or lift by one side only. FPC must have suitable stiffener.

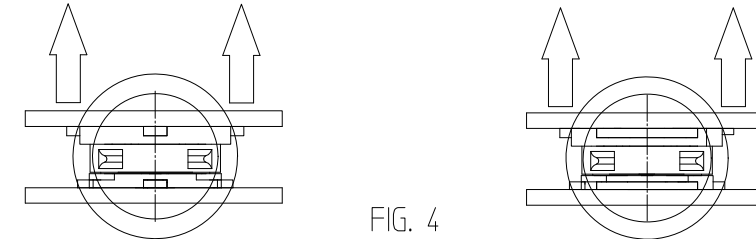

If encountering some resistance during the unmating start lifting from side as shown on fig. 5.  
Do not attempt unmating by lifting it from any of the other side.

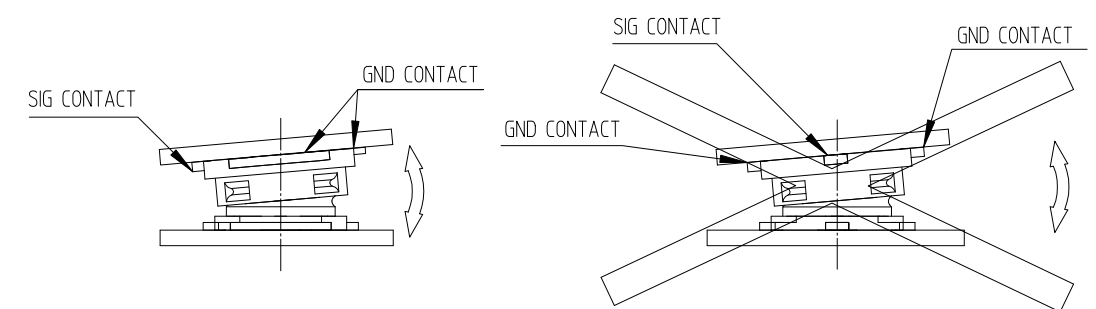

□ SUGGESTIONS TO PREVENT ACCIDENTAL UNMATING

In environments where the connectors may encounter severe shock, vibration or FPC's bend spring-back it is advisable to provide additional support when connectors are fully mated.  
E.G. : device chassis or compressive cushion.

 SCALE 10:1 UNITS mm	DRAWING NO.	EDC3-632121-80	PART NO.	K.FL2-PR-SMT09(800)
	HIROSE KOREA CO.,LTD.		CODE NO.	CL6345-0056-0-800
				2/2