

Dec.1.2024 Copyright 2024 HIROSE ELECTRIC CO., LTD. All Rights Reserved.  
In case of consideration for using Automotive equipment / device which demand high reliability, kindly contact our sales window correspondents.

COUNT	DESCRIPTION OF REVISIONS	B	Y	CHKD	DATE	COUNT	DESCRIPTION OF REVISIONS	B	Y	CHKD	DATE
△						△					
△						△					
△						△					

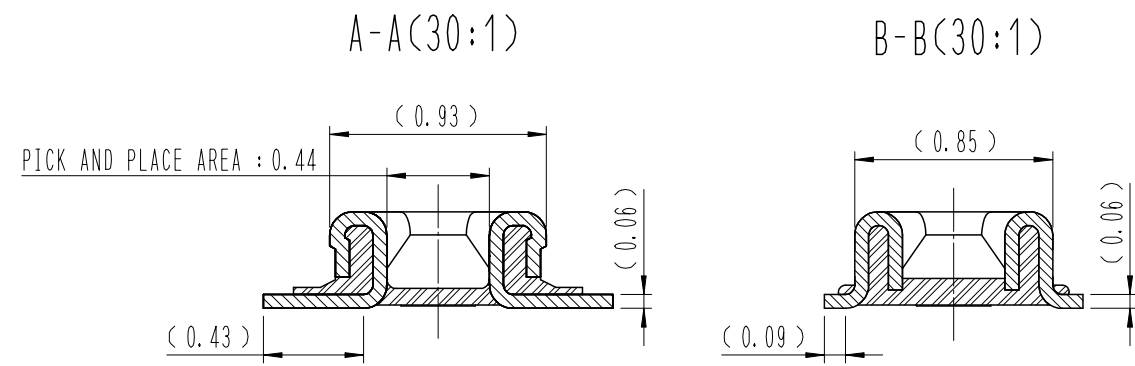

ENGAGEMENT FIGURE (30:1)

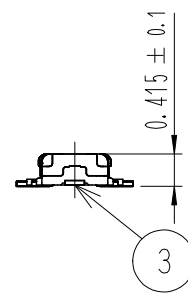
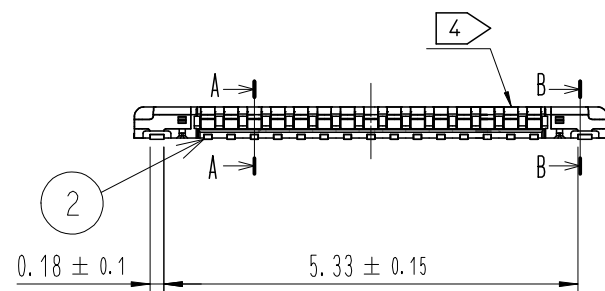
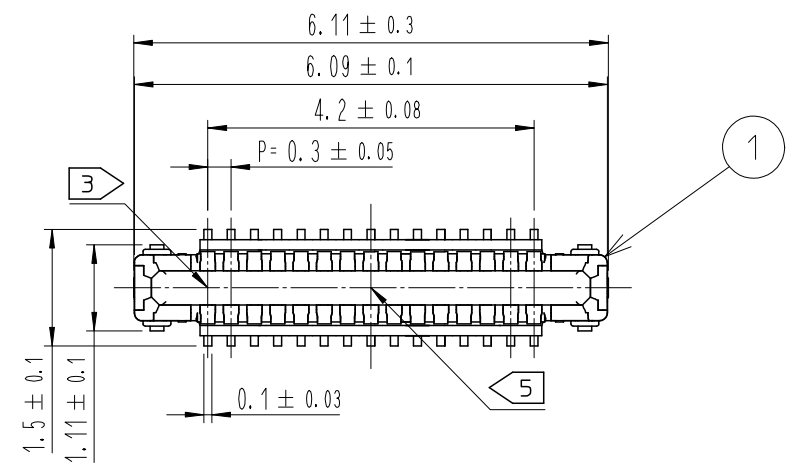
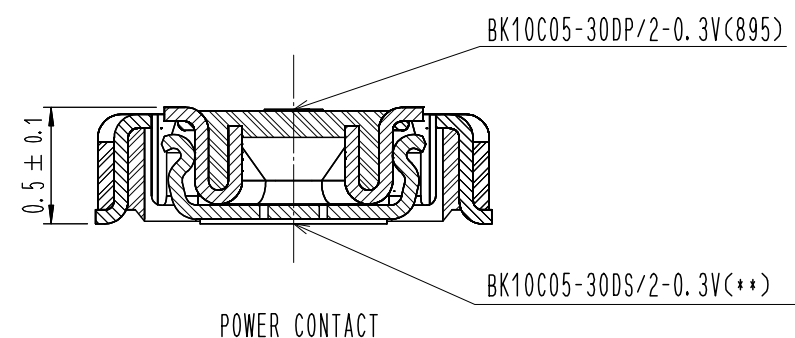
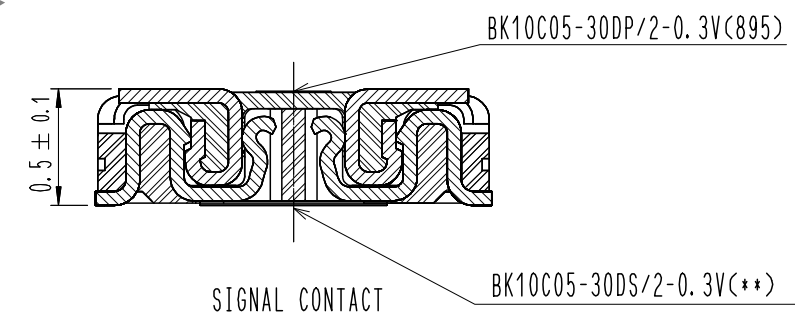

DRAWING FOR REFERENCE  
This is subject to change without notice

- NOTE
- 1 . ALL LEAD CO-PLANARITY SHALL BE 0.08mm MAX.
  - 2 CONTACT PLATING SPECIFICATIONS  
CONTACT AREA : GOLD 0.05 μm MIN  
SMT LEAD : GOLD 0.05 μm MIN  
UNDERPLATING : NICKEL 1 μm MIN  
( SURFACE : SEALING )
  - 3 CAV NO. ARE INDICATED IN APPROX POSITION SHOWN.
  - 4 A PART OF THE WALL COULD BE NOTCHED
  - 5 DENT EXISTS IN THE INDICATED AREA FOR MANUFACTURING CONVENIENCE.

4	PS	CLEAR (EMBOSSED CARRIER TAPE)			
3	COPPER ALLOY	2			
2	COPPER ALLOY	2	6	PS	BLACK (PLASTIC REEL)
1	LCP	UL94 V-0. BLACK	5	POLYESTER	CLEAR (COVER TAPE)
NO.	MATERIAL	FINISH , REMARKS	NO.	MATERIAL	FINISH , REMARKS

REMARKS		DRAWN	DESIGNED	CHECKED	APPROVED	RELEASED
		S. H. PARK	S. H. PARK	H. W. JO	H. W. JO	22.03.09
		22.03.09	22.03.09	22.03.09	22.03.09	

CODE NO. (OLD)		DRAWING NO.	PART NO.	
	SCALE	EDC3-633170-95	BK10C05-30DP/2-0.3V(895)	
	10:1	<b>HRS</b> HIROSE KOREA CO., LTD.	CODE NO	CL 6666-0043-4-895
	UNITS			
	mm			1/3

Dec.1.2024 Copyright 2024 HIROSE ELECTRIC CO., LTD. All Rights Reserved.  
In case of consideration for using Automotive equipment / device which demand high reliability, kindly contact our sales window correspondents.

7 RECOMMENDED PCB LAYOUT

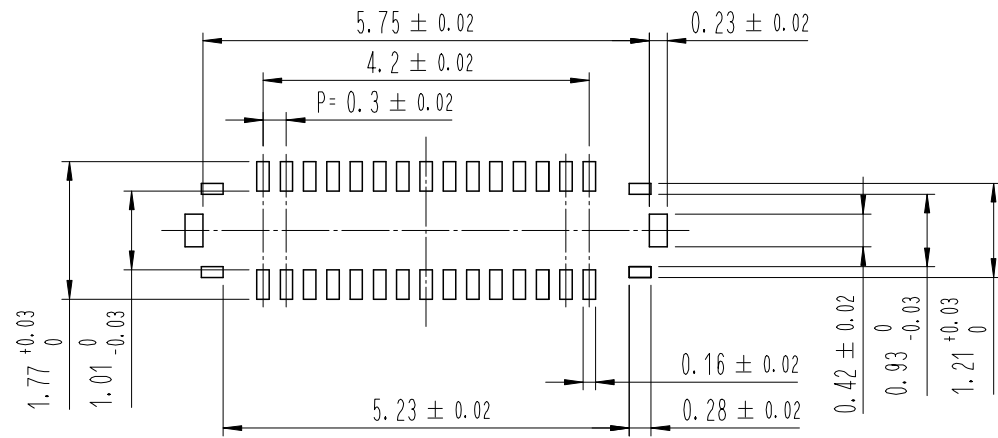

RECOMMENDED METAL MASK DIMENSIONS

MATAL MASK THICKNESS : 80 μm

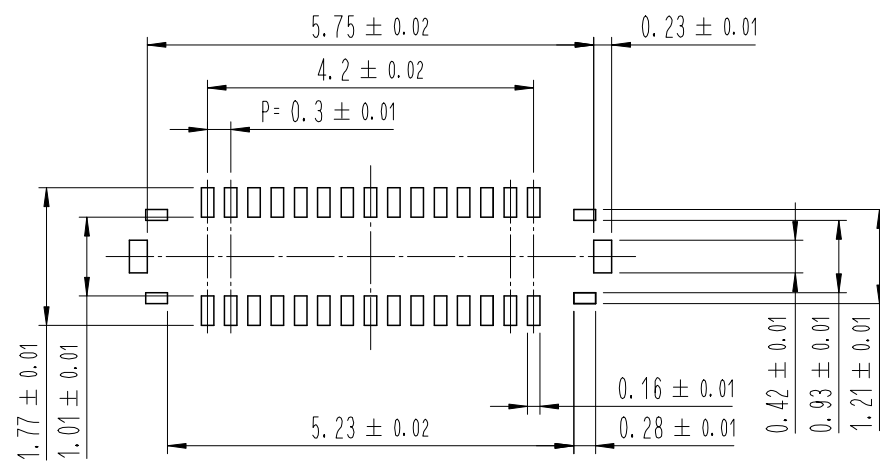

6 RECOMMENDED REFLOW TEMPERATURE PROFILE USING LEAD-FREE SOLDER PASTE.

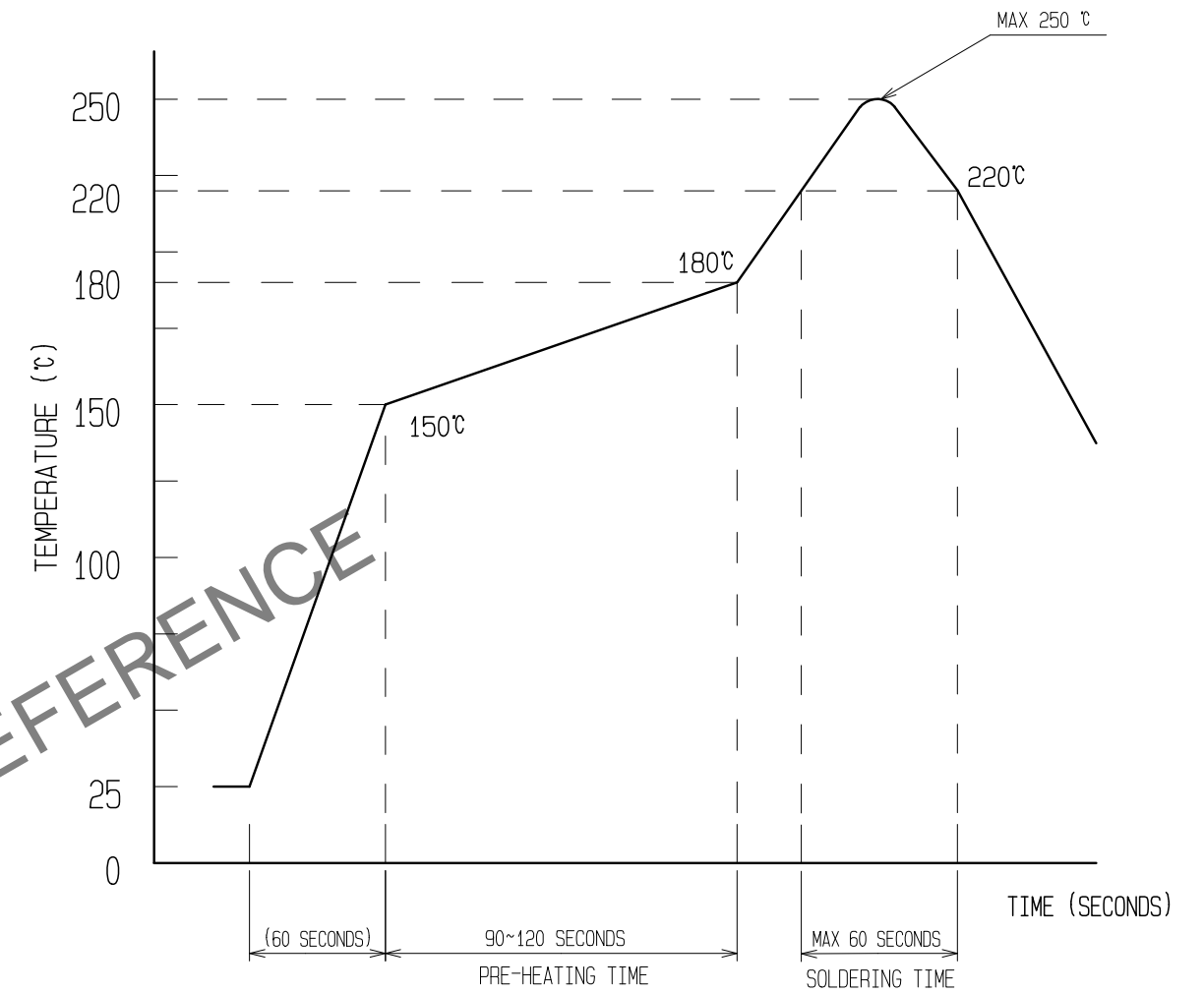

- REFLOW METHOD : N<sub>2</sub> REFLOW  
 NUMBER OF REFLOW CYCLES : 2 CYCLES MAX.  
 1) REFLOW TIME  
 DURATION ABOVE 220°C, 60 SEC MAX.  
 (PEAK TEMPERATURE : 250°C MAX)  
 2) PRE-HEAT TIME  
 PRE-HEAT TEMPERATURE(MIN): 150°C  
 PRE-HEAT TEMPERATURE(MAX): 180°C  
 PRE-HEAT TIME: 90-120 SEC.

6 THIS TEMPERATURE PROFILE IS PER THE CONDITIONS SHOWN ABOVE. ADDITIONAL FACTORS SUCH AS SOLDER PASTE TYPE, PCB SIZE AND OTHER MOUNTED COMPONENTS COULD AFFECT THE PROFILE. THEREFORE, A THOROUGH EVALUATION OF MOUNTING CONDITION IS REQUIRED PRIOR TO PRODUCTION. TEMPERATURE IS MEASURED AT CONTACT LEAD.

- 7 PLEASE CONTACT US IN CASE YOU WILL MAKE DIFFERENT SETTINGS FROM OUR RECOMMENDATION.  
 8 . THIS PRODUCT SATISFIES HALOGEN FREE REQUIREMENTS DEFINED AS 900ppm MAXIMUM CHLORINE, 900ppm MAXIMUM BROMINE, AND 1500ppm MAXIMUM TOTAL OF CHLORINE AND BROMINE.  
 9 . THIS PRODUCT COMPLY WITH RoHS.

HRS DRAWING FOR REFERENCE

 SCALE 10:1 UNITS mm	DRAWING NO.	EDC3-633170-95	PART NO.	BK10C05-30DP/2-0.3V(895)
	HIROSE KOREA CO., LTD.		CODE NO.	CL 6666-0043-4-895
				2/3

Dec.1.2024 Copyright 2024 HIROSE ELECTRIC CO., LTD. All Rights Reserved.  
In case of consideration for using Automotive equipment / device which demand high reliability, kindly contact our sales window correspondents.

# EMBOSSED CARRIER TAPE PACKAGING (5:1)

# STYLE AND DIMENSION OF REEL (FREE)

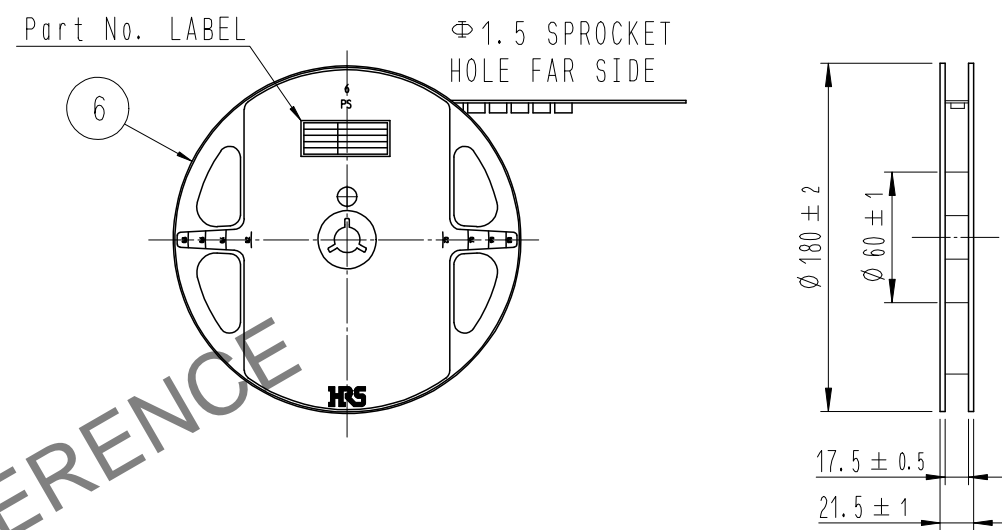
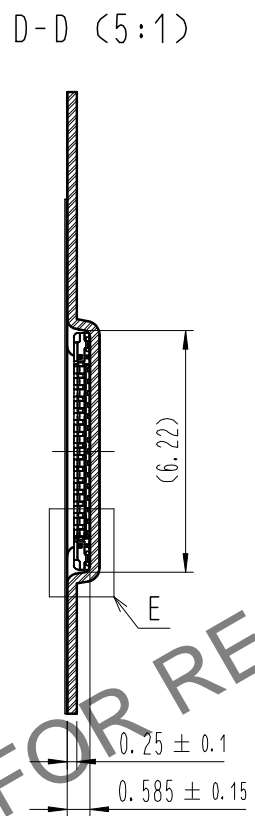
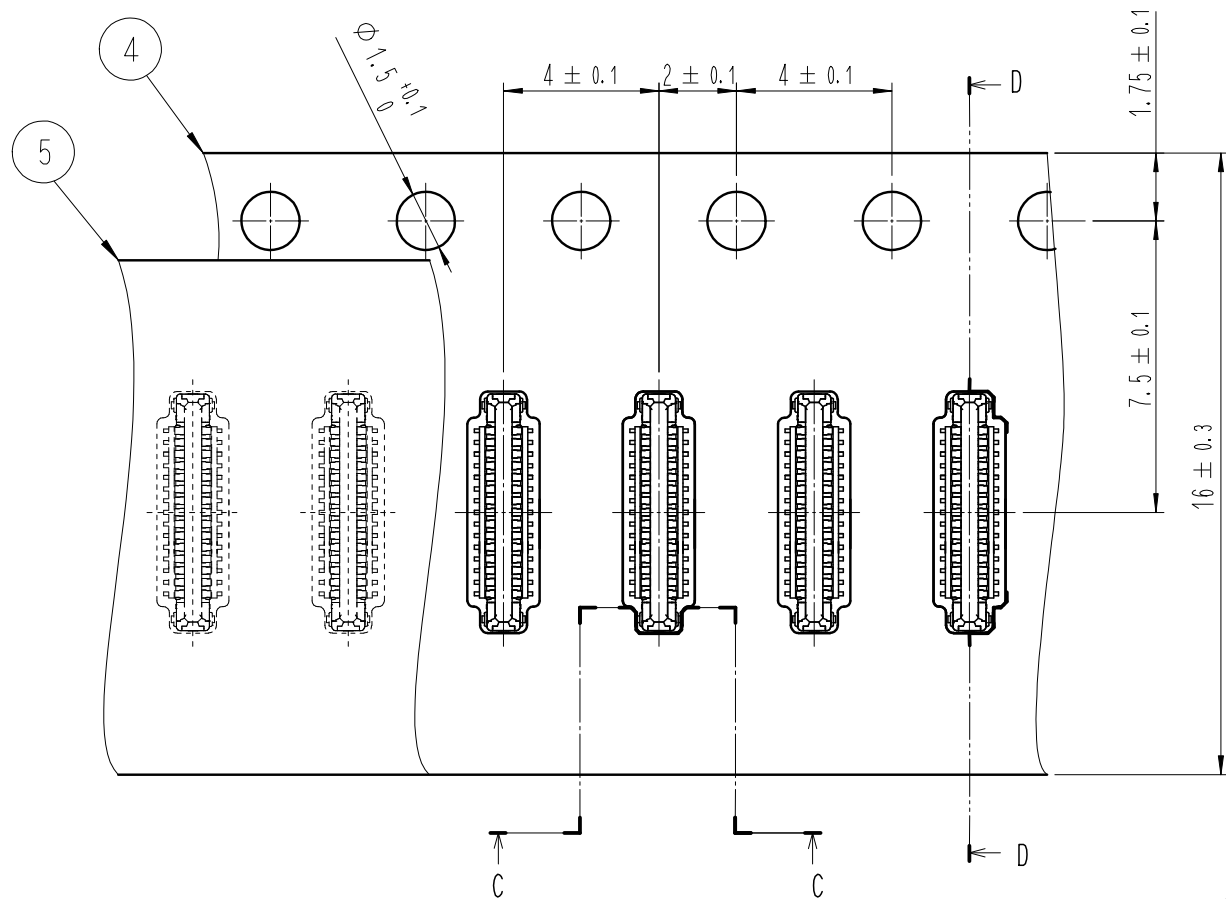

C-C (5:1)

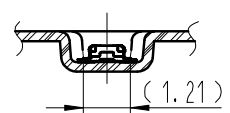

DIRECTION OF UNREELING

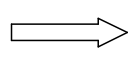

E (10:1)

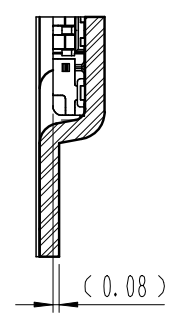

## DETAIL OF PART No. LABEL

SUPPLIER	HIROSE ELECTRIC CO., LTD.
QUANTITY	1,000
PART NO.	BK10C05-30DP/2-0.3V(895)
CODE NO.	CL 6666-0043-4-895
DATE OF MANUFACTURED	生産月日 年 月 日
箱番	** ** *
品名	BK10C05-30DP/2-0.3V(895)
納入数量	1,000個
納入者	HIROSE KOREA

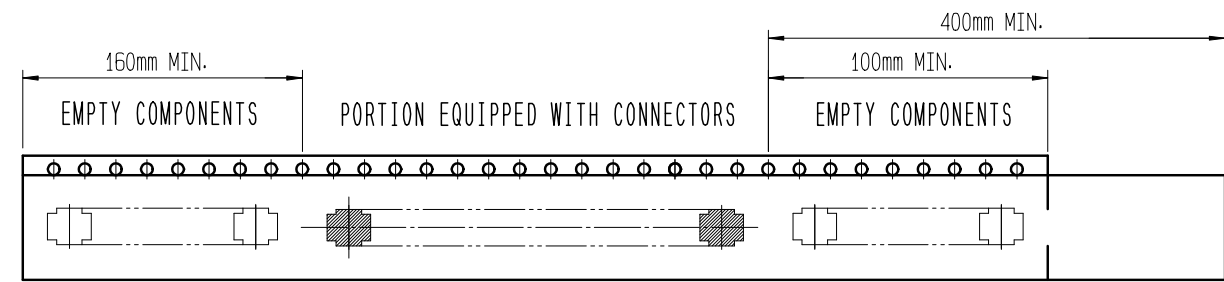

TAPING(FREE)

- 10 . PER REEL 1,000 CONNECTORS.
- 11 . THE DIMENSIONS IN PARENTHESES ARE FOR REFERENCE.
- 12 > REFER TO JIS C 0806, IEC-60286-3 (PACKAGING OF COMPONENTS FOR AUTOMATIC HANDLING)

	DRAWING NO.	EDC3-633170-95	PART NO.	BK10C05-30DP/2-0.3V(895)	
	SCALE	10:1	CODE NO.	CL 6666-0043-4-895	3/3
UNITS	HRS HIROSE KOREA CO., LTD.				