

Mar.1.2026 Copyright 2026 HIROSE ELECTRIC CO., LTD. All Rights Reserved.  
In case of consideration for using Automotive equipment / device which demand high reliability, kindly contact our sales window correspondents.

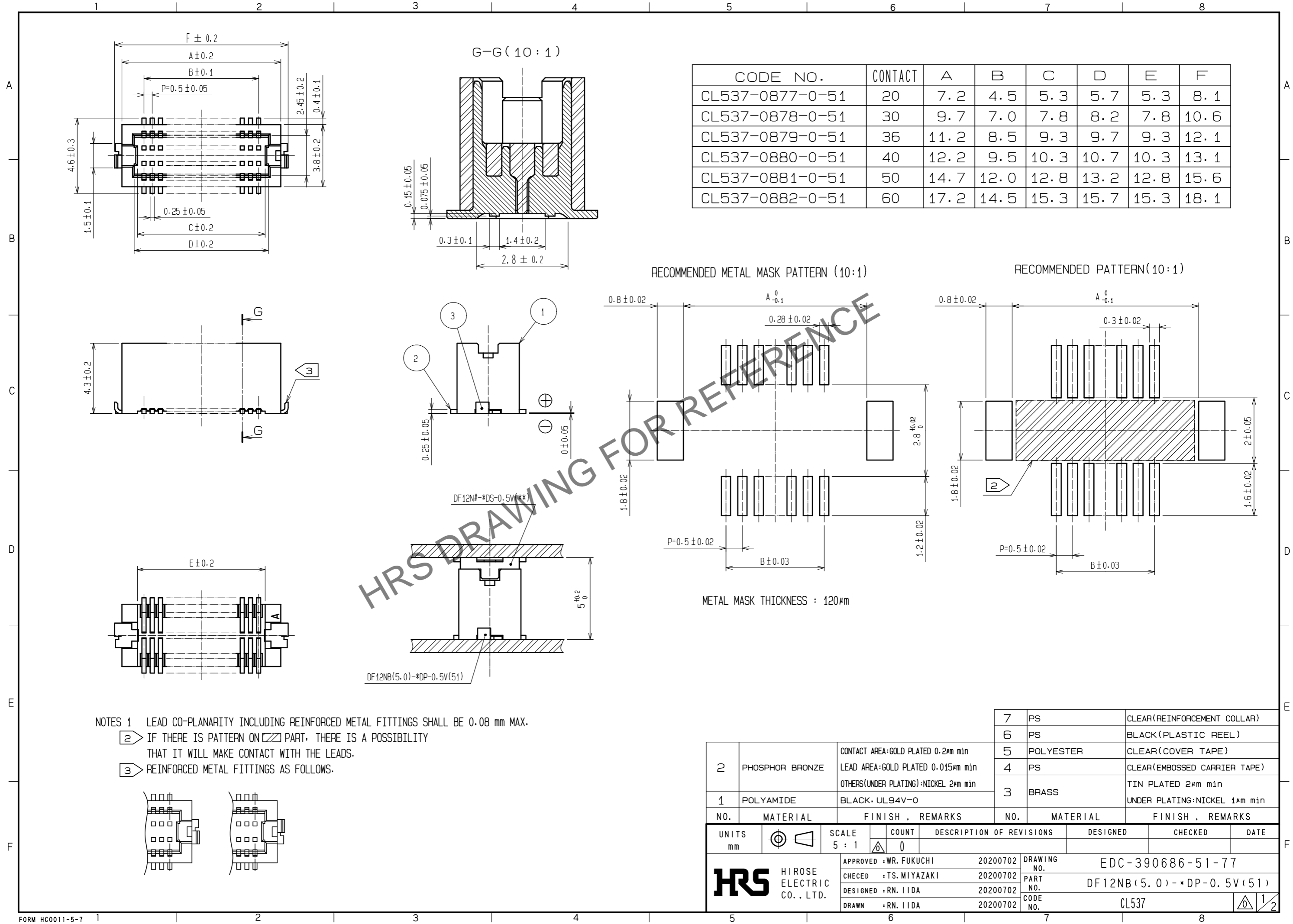

CODE NO.	CONTACT	A	B	C	D	E	F
CL537-0877-0-51	20	7.2	4.5	5.3	5.7	5.3	8.1
CL537-0878-0-51	30	9.7	7.0	7.8	8.2	7.8	10.6
CL537-0879-0-51	36	11.2	8.5	9.3	9.7	9.3	12.1
CL537-0880-0-51	40	12.2	9.5	10.3	10.7	10.3	13.1
CL537-0881-0-51	50	14.7	12.0	12.8	13.2	12.8	15.6
CL537-0882-0-51	60	17.2	14.5	15.3	15.7	15.3	18.1

RECOMMENDED METAL MASK PATTERN (10:1)

RECOMMENDED PATTERN(10:1)

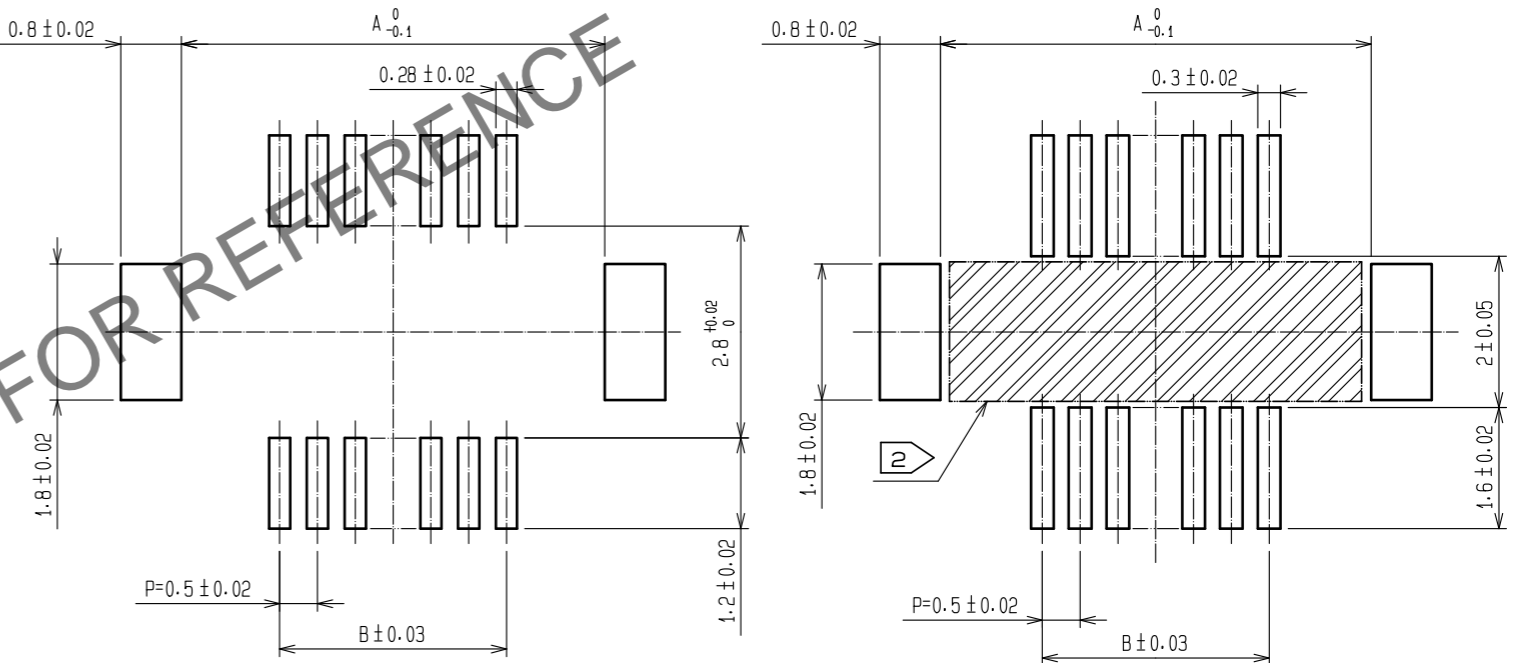

- NOTES 1 LEAD CO-PLANARITY INCLUDING REINFORCED METAL FITTINGS SHALL BE 0.08 mm MAX.  
 2 IF THERE IS PATTERN ON PART, THERE IS A POSSIBILITY THAT IT WILL MAKE CONTACT WITH THE LEADS.  
 3 REINFORCED METAL FITTINGS AS FOLLOWS.

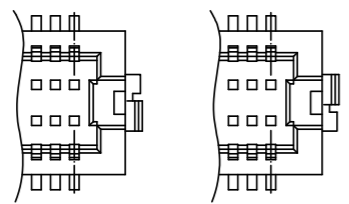

NO.	MATERIAL	FINISH . REMARKS	NO.	MATERIAL	FINISH . REMARKS
2	PHOSPHOR BRONZE	CONTACT AREA:GOLD PLATED 0.2μm min LEAD AREA:GOLD PLATED 0.015μm min OTHERS(UNDER PLATING):NICKEL 2μm min	7	PS	CLEAR(REINFORCEMENT COLLAR)
1	POLYAMIDE	BLACK, UL94V-0	6	PS	BLACK(PLASTIC REEL)
			5	POLYESTER	CLEAR(COVER TAPE)
			4	PS	CLEAR(EMBOSSED CARRIER TAPE)
			3	BRASS	TIN PLATED 2μm min UNDER PLATING:NICKEL 1μm min

  

UNITS	SCALE	COUNT	DESCRIPTION OF REVISIONS	DESIGNED	CHECKED	DATE
mm	5 : 1	0				

  

<b>HRS</b> HIROSE ELECTRIC CO., LTD.	APPROVED : WR. FUKUCHI	20200702	DRAWING NO.	EDC-390686-51-77
	CHECED : TS. MIYAZAKI	20200702	PART NO.	DF12NB(5.0)- *DP-0.5V(51)
	DESIGNED : RN. IIDA	20200702	CODE NO.	CL537
	DRAWN : RN. IIDA	20200702		

Mar.1.2026 Copyright 2026 HIROSE ELECTRIC CO., LTD. All Rights Reserved.  
 In case of consideration for using Automotive equipment / device which demand high reliability, kindly contact our sales window correspondents.

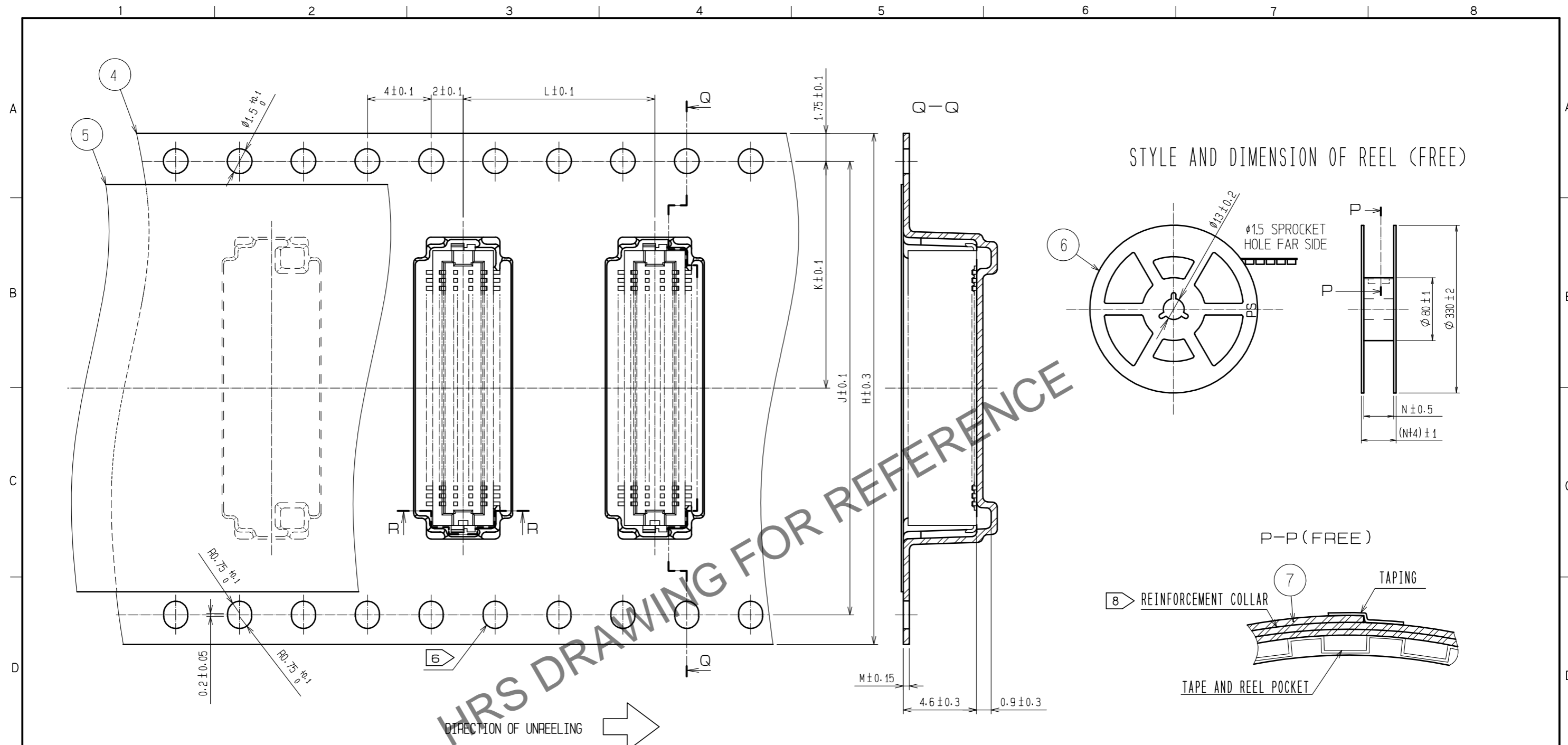

STYLE AND DIMENSION OF REEL (FREE)

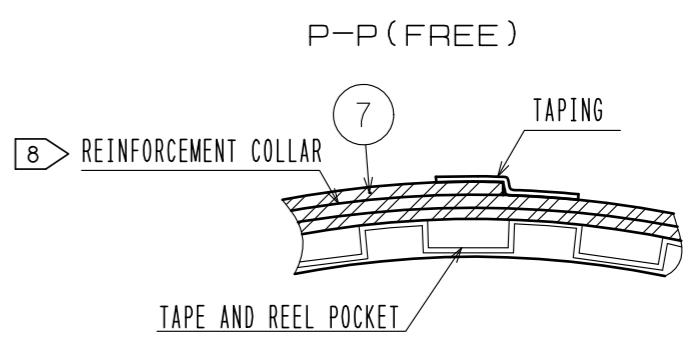
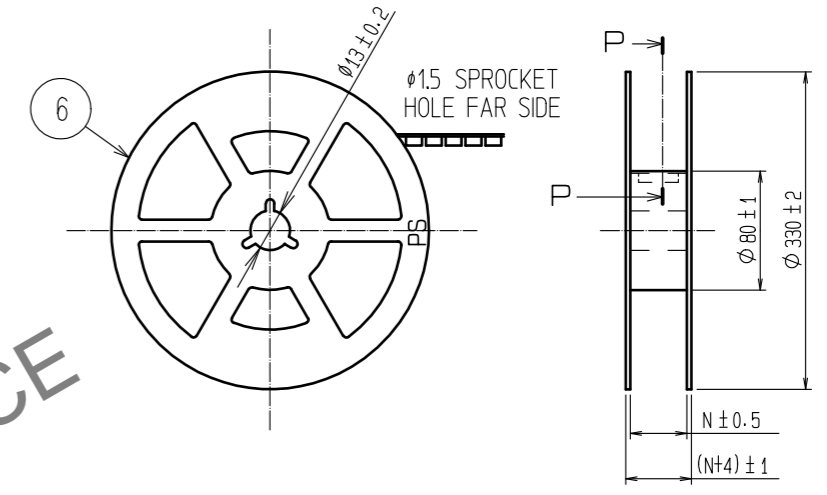

HRS DRAWING FOR REFERENCE

CODE No.	CONTACT	H	J	K	L	M	N
CL537-0877-0-51	20	16	-	7.5	12	0.38	17.5
CL537-0878-0-51	30	24	-	11.5	12	0.38	25.5
CL537-0879-0-51	36	24	-	11.5	12	0.38	25.5
CL537-0880-0-51	40	24	-	11.5	12	0.38	25.5
CL537-0881-0-51	50	24	-	11.5	8	0.30	25.5
CL537-0882-0-51	60	32	28.4	14.2	12	0.30	33.5

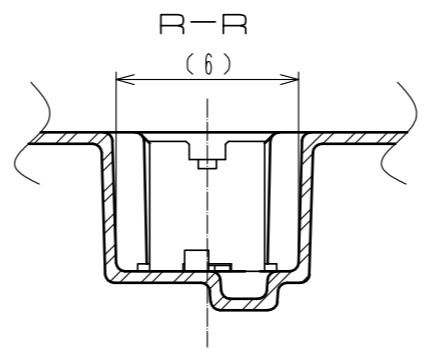

- NOTES
- 4 1 REEL 1000 CONNECTORS.
  - 5 AT THE BEGINNING OF THE REEL, 30 COMPONENTS SHALL BE EMPTY.  
AT THE END OF THE REEL, 20 COMPONENTS SHALL BE EMPTY.
  - 6 WHEN THE TAPE WIDTH IS 32 mm, SPROCKET HOLES SHALL BE SET ON BOTH SIDE OF REEL AS SHOWN ON THIS DRAWING.
  - 7 PEEL FORCE REFERS TO JIS C 0806. (IEC 60286-3)
  - 8 AFTER PACKING, ROLL 2 METERS OF THE REINFORCEMENT COLLAR TO OUTER CIRCUMFERENCE OF TAPE AND REEL POCKET, AND TAPE DOWN AT THE END THE COLLAR.

<b>HRS</b>	DRAWING NO.	EDC-390686-51-77	
	PART NO.	DF12NB(5.0)-*DP-0.5V(51)	
	CODE NO.	CL537	2/2