

Jan.1.2025 Copyright 2025 HIROSE ELECTRIC CO., LTD. All Rights Reserved.
 In case of consideration for using Automotive equipment / device which demand high reliability, kindly contact our sales window correspondents.

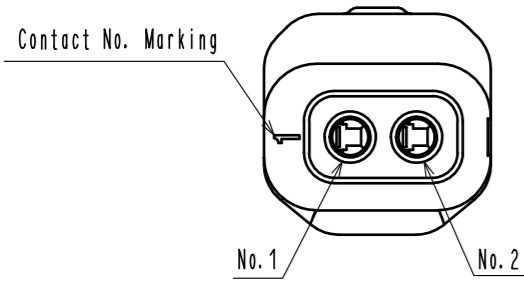
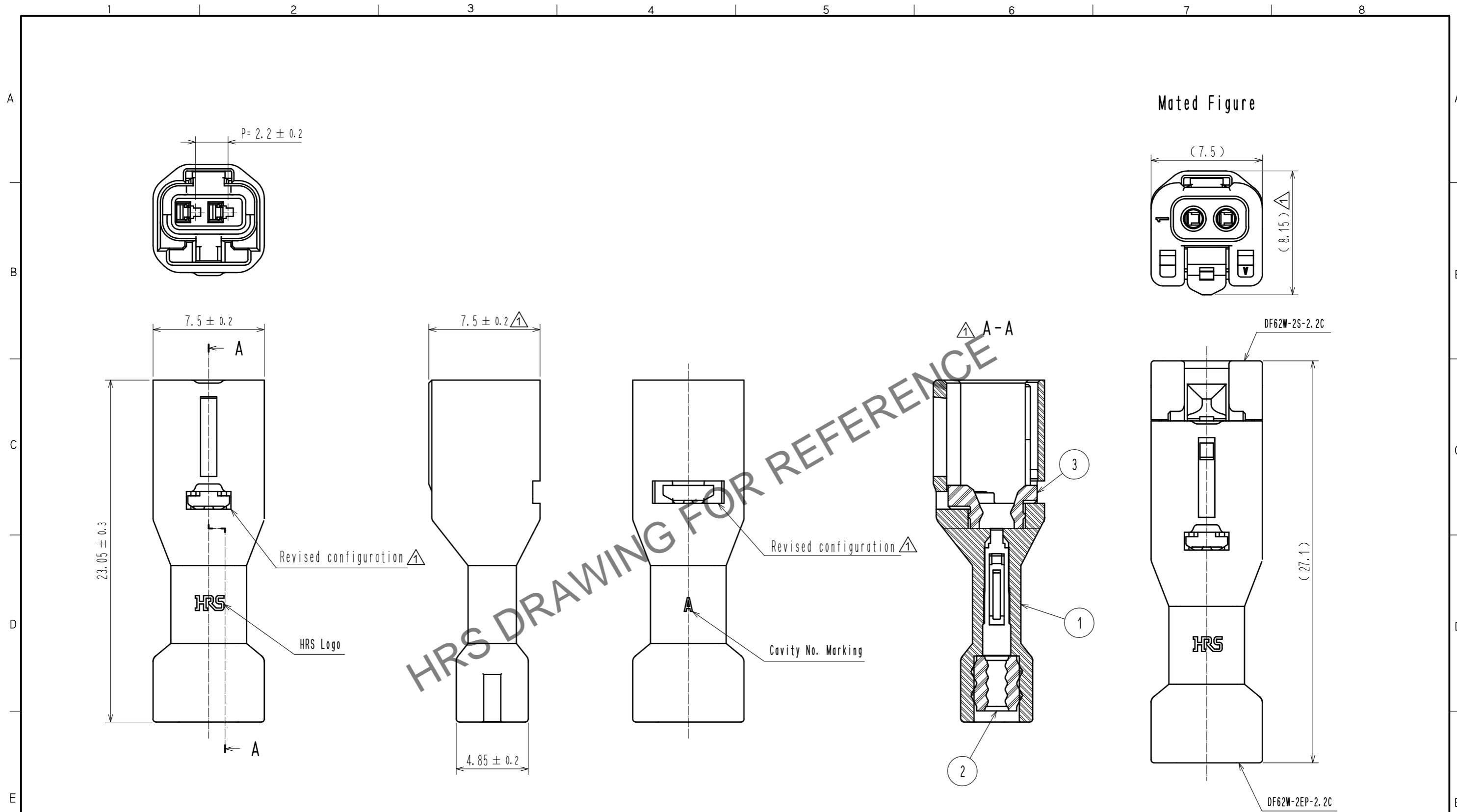

- Notes.**
1. 100 pcs. / bag
 2. The dimensions in parenthesis are reference dimensions.
 3. Always refer to the manuals below for operation of this product.
 For Cable assembly / Cable assembly procedure ATAD-H0760
 For Mating/Unmating / Operation manual ATAD-H0761

NO.	MATERIAL	FINISH . REMARKS	NO.	MATERIAL	FINISH . REMARKS
1	PBT	UL94V-0 (Black)	3	Silicone rubber	Bengala
			2	Silicone rubber	Bengala

UNITS	SCALE	COUNT	DESCRIPTION OF REVISIONS	DESIGNED	CHECKED	DATE
mm	4 : 1	6	DIS-H-00000241	TS.MIYAKI	TS.FUKUSHIMA	15.03.17

APPROVED	: KI. AKIYAMA	14.01.09	DRAWING NO.	EDC3-353518-00
CHECKED	: MN. KENJO	14.01.09	PART NO.	DF62W-2EP-2.2C
DESIGNED	: TO. HORII	14.01.08	CODE NO.	CL544-1003-0-00
DRAWN	: TO. HORII	14.01.08		