

Jul.1.2024 Copyright 2024 HIROSE ELECTRIC CO., LTD. All Rights Reserved.  
 In case of consideration for using Automotive equipment / device which demand high reliability, kindly contact our sales window correspondents.

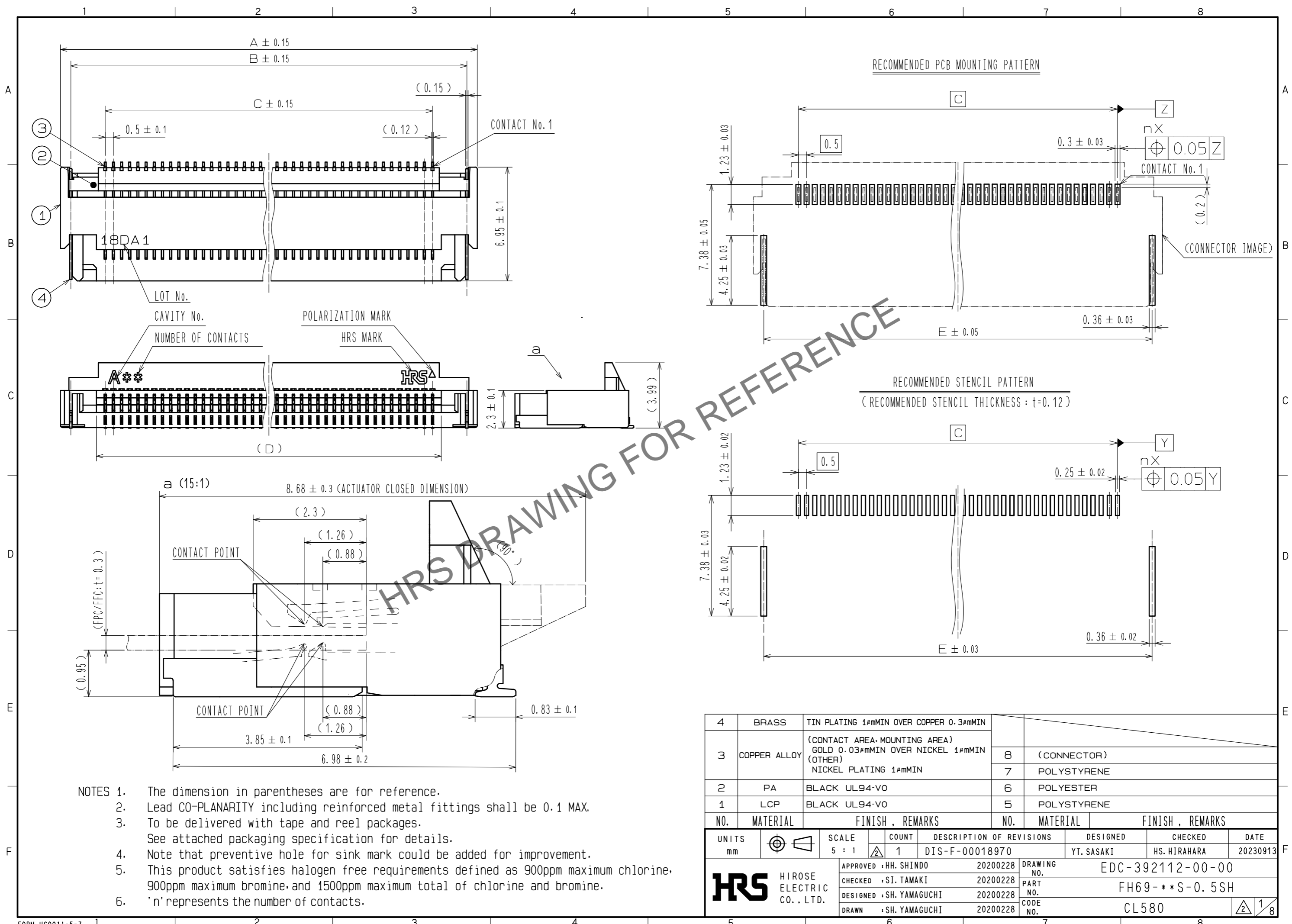

- NOTES
- The dimension in parentheses are for reference.
  - Lead CO-PLANARITY including reinforced metal fittings shall be 0.1 MAX.
  - To be delivered with tape and reel packages.  
See attached packaging specification for details.
  - Note that preventive hole for sink mark could be added for improvement.
  - This product satisfies halogen free requirements defined as 900ppm maximum chlorine, 900ppm maximum bromine, and 1500ppm maximum total of chlorine and bromine.
  - 'n' represents the number of contacts.

4	BRASS	TIN PLATING 1#mMIN OVER COPPER 0.3#mMIN										
3	COPPER ALLOY	(CONTACT AREA, MOUNTING AREA) GOLD 0.03#mMIN OVER NICKEL 1#mMIN (OTHER) NICKEL PLATING 1#mMIN	8	(CONNECTOR)								
2	PA	BLACK UL94-V0	7	POLYSTYRENE								
1	LCP	BLACK UL94-V0	6	POLYESTER								
			5	POLYSTYRENE								
NO.	MATERIAL	FINISH, REMARKS	NO.	MATERIAL	FINISH, REMARKS							
UNITS	mm	SCALE	5 : 1	COUNT	1	DESCRIPTION OF REVISIONS	DESIGNED	Y.T. SASAKI	CHECKED	HS. HIRAHARA	DATE	20230913
APPROVED		: HH. SHINDO		20200228		DRAWING NO.		EDC-392112-00-00				
CHECKED		: SI. TAMAKI		20200228		PART NO.		FH69-***S-0.5SH				
DESIGNED		: SH. YAMAGUCHI		20200228		CODE NO.		CL580				
DRAWN		: SH. YAMAGUCHI		20200228								

Jul.1.2024 Copyright 2024 HIROSE ELECTRIC CO., LTD. All Rights Reserved.  
 In case of consideration for using Automotive equipment / device which demand high reliability, kindly contact our sales window correspondents.

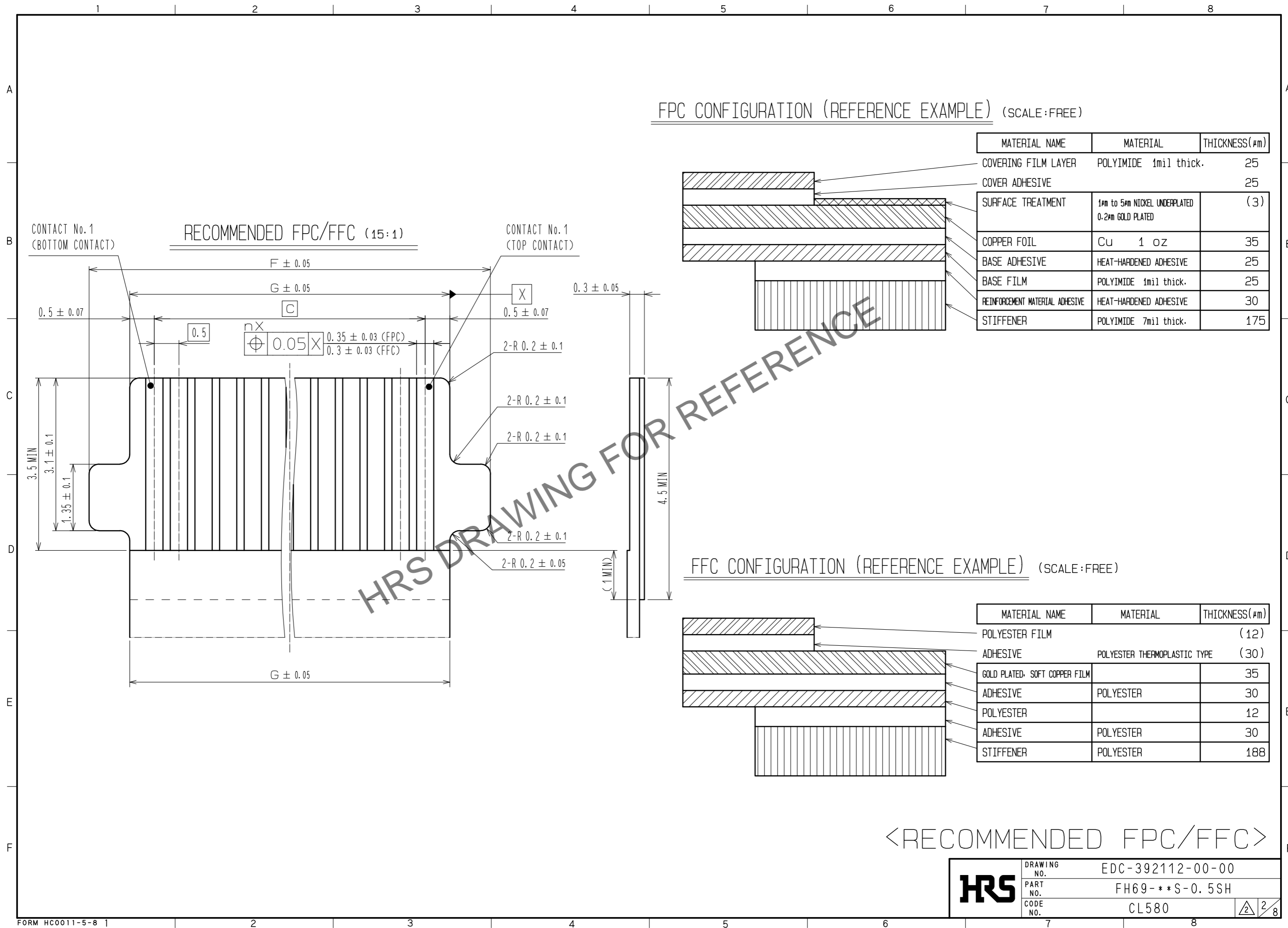

<RECOMMENDED FPC/FFC>

<b>HRS</b>	DRAWING NO.	EDC-392112-00-00
	PART NO.	FH69-**S-0.5SH
	CODE NO.	CL580
		2/8

Jul.1.2024 Copyright 2024 HIROSE ELECTRIC CO., LTD. All Rights Reserved.  
 In case of consideration for using Automotive equipment / device which demand high reliability, kindly contact our sales window correspondents.

# EMBOSED CARRIER TAPE DIMENSION (2:1)

# REEL DIMENSION (FREE)

■ TAPE WIDTH: 24mm MAX

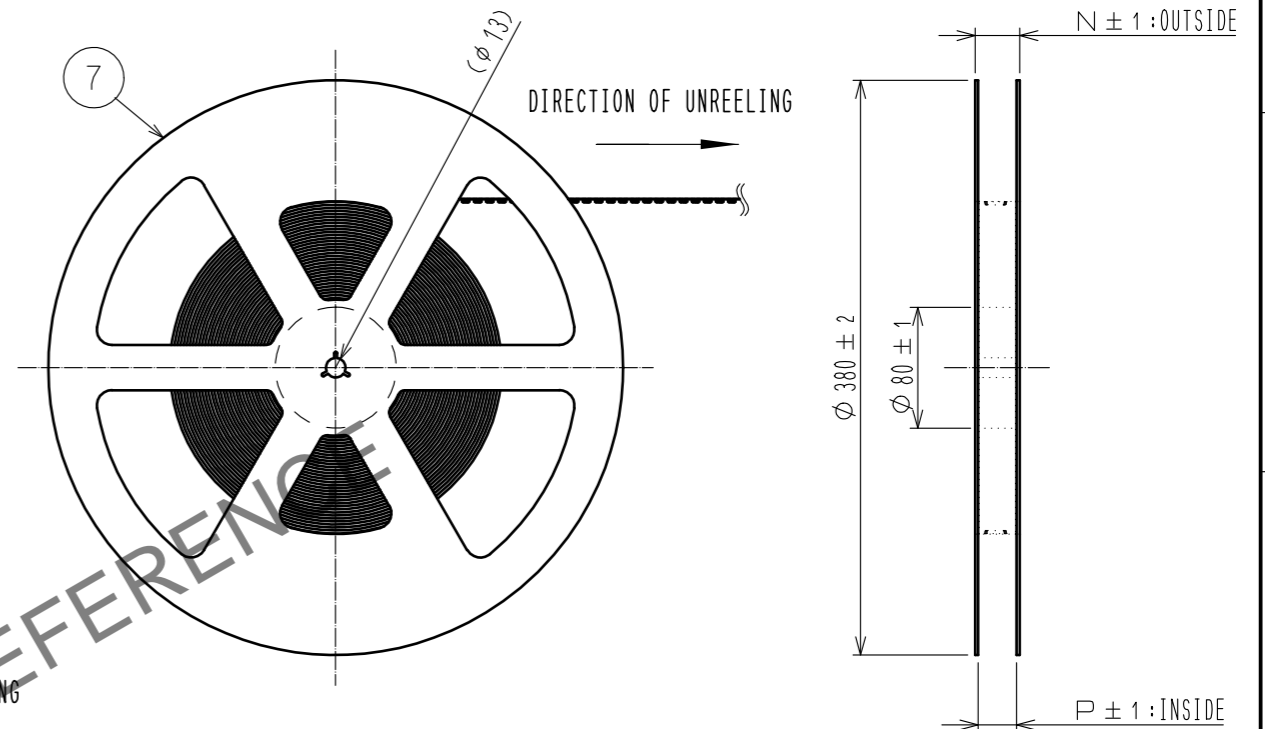
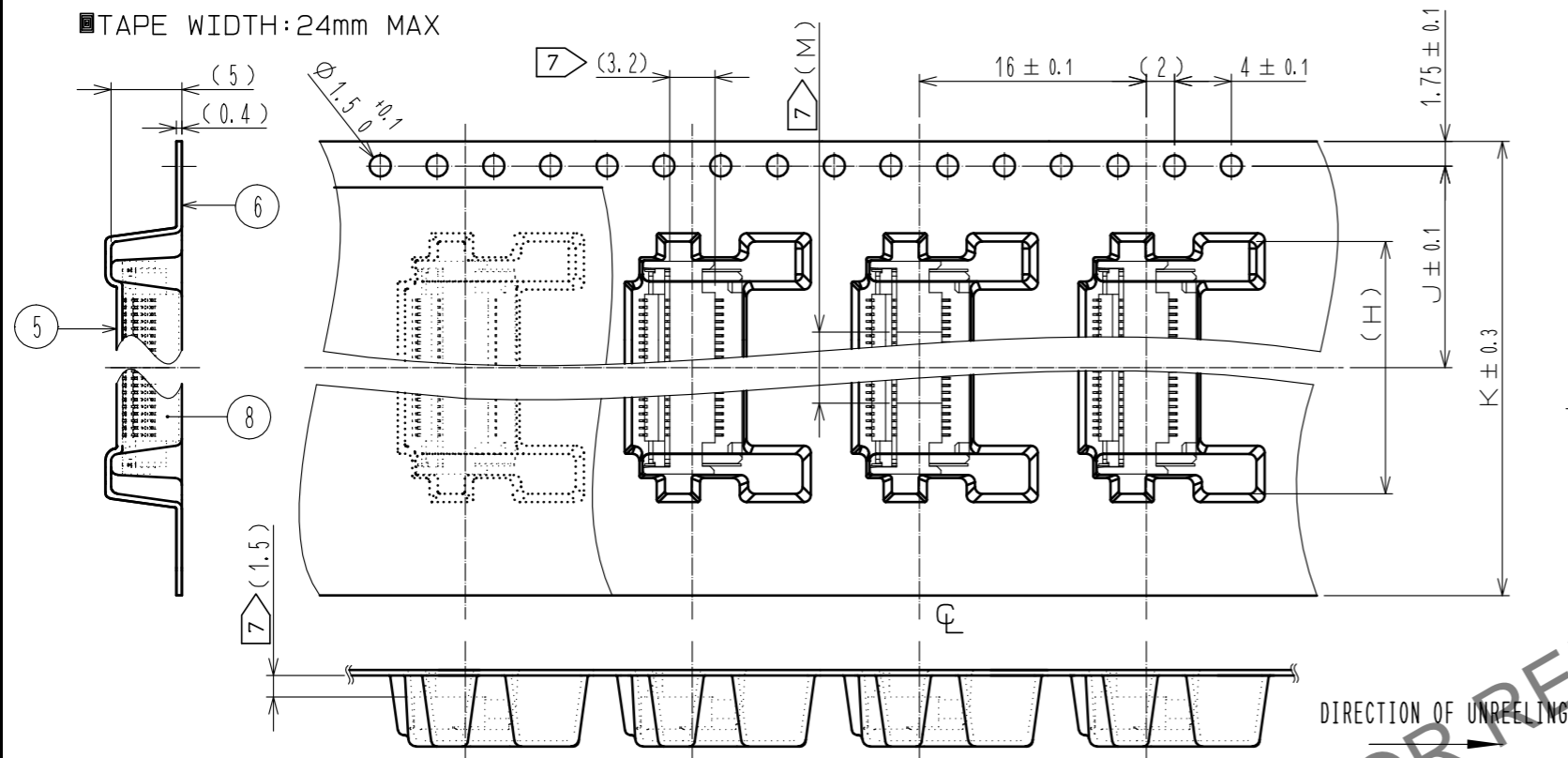

■ TAPE WIDTH: 32mm MIN

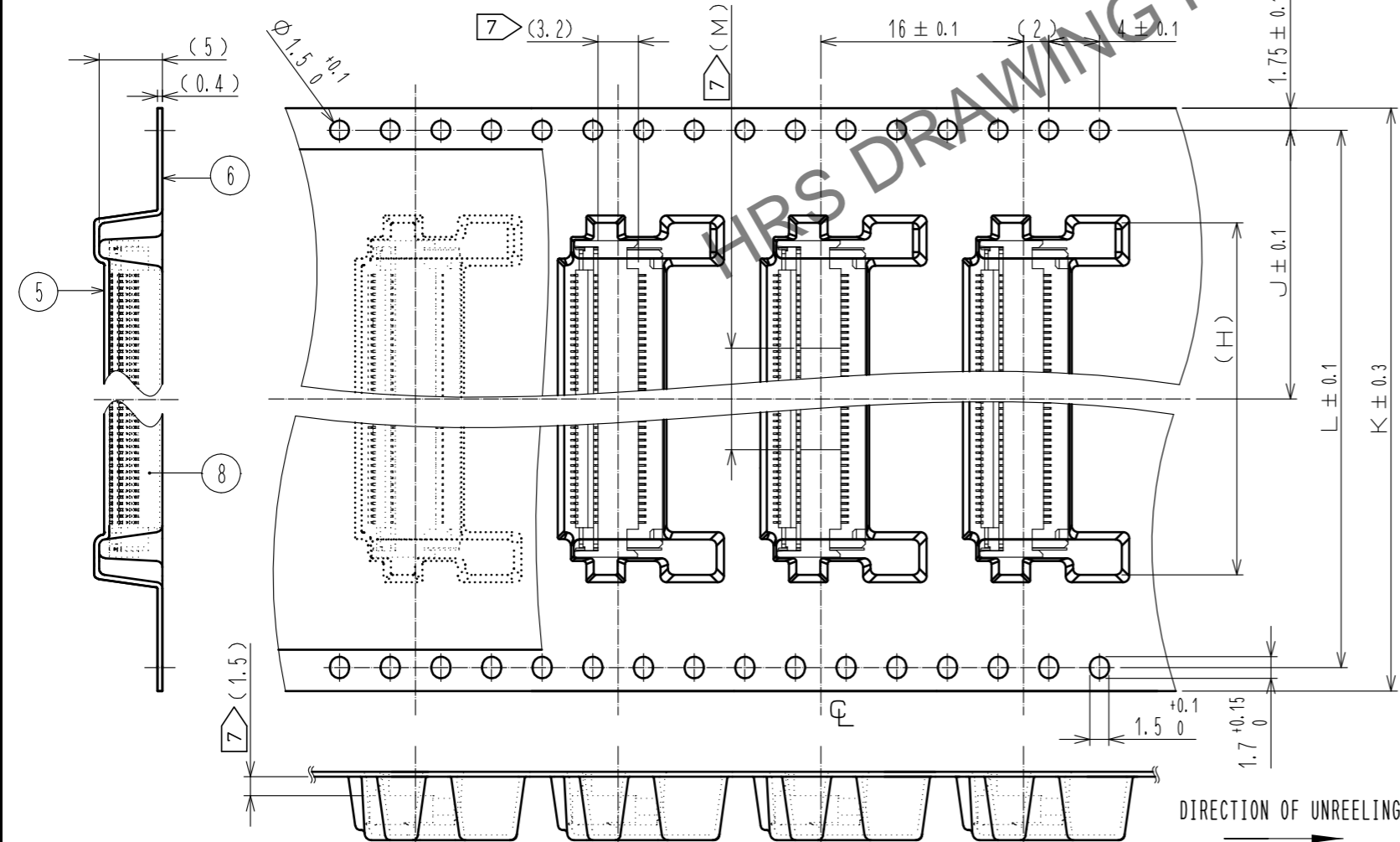

# LEADER, TRAILER DIMENSION (FREE)

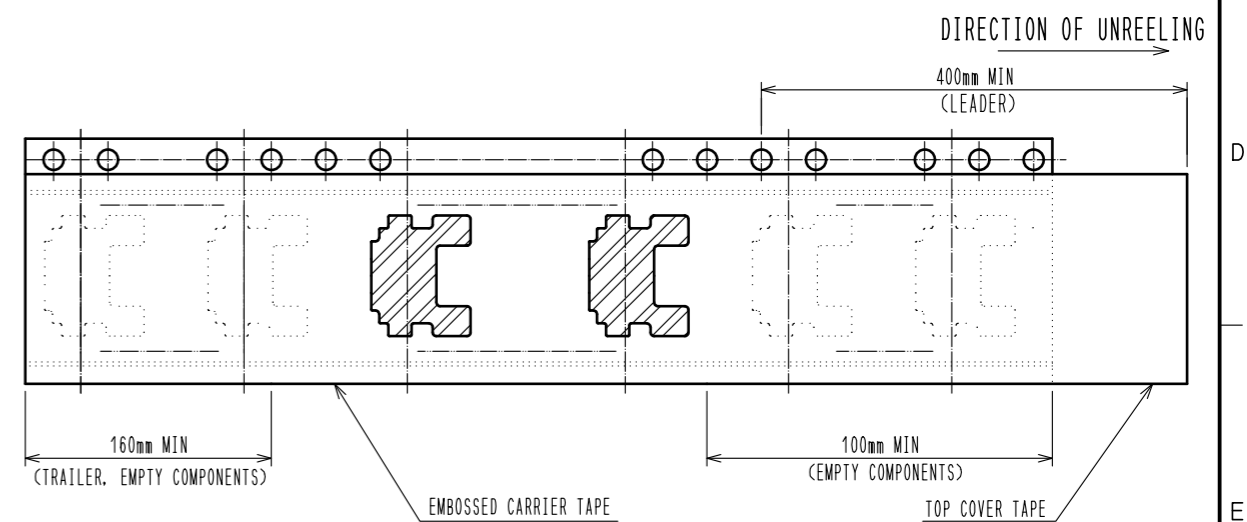

- NOTES
- 7 The indicated dimension indicates the pick-up area or pick-up position for automatic mounting.
  - 8. 1 reel : 1000 connectors.
  - 9. Refer to JIS C 0806 and IEC 60286-3. (Packaging of components for automatic mounting.)

# <PACKING SPECIFICATION>

<b>HRS</b>	DRAWING NO.	EDC-392112-00-00
	PART NO.	FH69-**-S-0.5SH
	CODE NO.	CL580
		3/8

Jul.1.2024 Copyright 2024 HIROSE ELECTRIC CO., LTD. All Rights Reserved.  
 In case of consideration for using Automotive equipment / device which demand high reliability, kindly contact our sales window correspondents.

PART NUMBER	CODE NUMBER	NUMBER OF CONTACT	DIMENSION OF CONNECTOR, PCB MOUNTING PATTERN, AND FFC/FPC								DIMENSION OF DRAWING FOR PACKING					
			A	B	C	D	E	F	G	H	J	K	L	M	N	P
FH69-10S-0.5SH	CL580-5003-0-00	10	9.98	8.7	4.5	5.57	8.73	7.15	5.5	12.66	11.5	24	-	5.0	29.4	25.4
FH69-20S-0.5SH	—	20	14.98	13.7	9.5	10.57	13.73	12.15	10.5	17.66	14.2	32	28.4	8.0	37.4	33.4
FH69-30S-0.5SH	CL580-5004-0-00	30	19.98	18.7	14.5	15.57	18.73	17.15	15.5	22.66	20.2	44	40.4	8.0	49.4	45.4
FH69-40S-0.5SH	CL580-5006-0-00	40	24.98	23.7	19.5	20.57	23.73	22.15	20.5	27.66	20.2	44	40.4	8.0	49.4	45.4
FH69-50S-0.5SH	CL580-5008-0-00	50	29.98	28.7	24.5	25.57	28.73	27.15	25.5	32.66	26.2	56	52.4	8.0	61.4	57.4
FH69-60S-0.5SH	CL580-5007-0-00	60	34.98	33.7	29.5	30.57	33.73	32.15	30.5	37.66	26.2	56	52.4	8.0	61.4	57.4

※THE PRODUCTS WITHOUT CODE NUMBER ARE CURRENTLY UNDER PLANNING.  
 PLEASE CONTACT HIROSE FOR DETAILED INFORMATION ABOUT PRODUCT VARIATION.

<DIMENSION TABLE>

<b>HRS</b>	DRAWING NO.	EDC-392112-00-00
	PART NO.	FH69-***S-0.5SH
	CODE NO.	CL580

△ 4/8

In case of consideration for using Automotive equipment / device which demand high reliability, kindly contact our sales window correspondents.

To prevent connector/FPC breakage and contact failure (mating failure, FPC pattern breakage, etc), read through the instructions shown below and handle the connector properly. Although this instruction manual is applicable to usage with FPC/FFC.

[Connector Part Nomenclature]

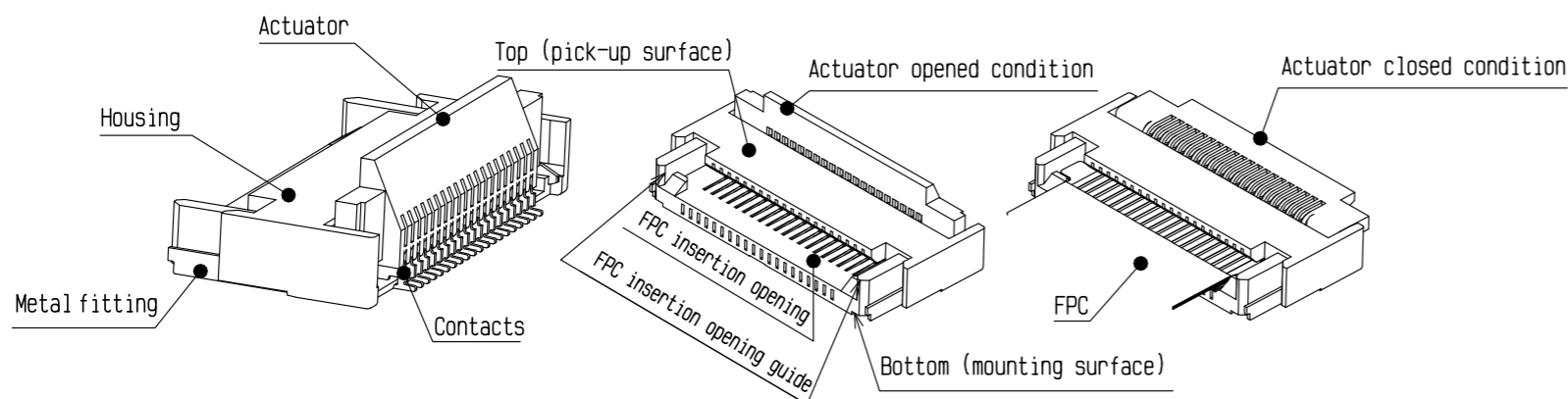

[Operation and cautions]

1. Initial condition

Actuator does not have to be operated before inserting FPC, as the connector is delivered with the actuator opened.

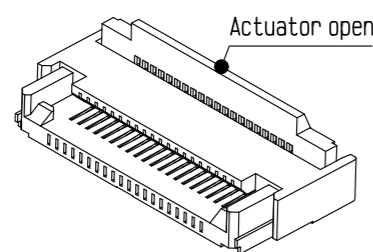

- When delivered -

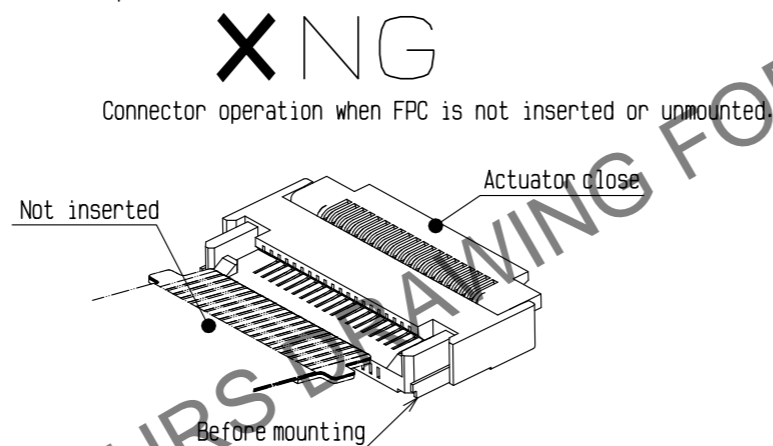

2. How to insert and remove FPC

- When inserting the FPC, insert the FPC at about 10 degree angle to the PCB mounting surface. Also, please position both ends of the FPC by insertion opening guide and then insert it straightly.
- When removing the FPC, please pull it out diagonally upward so that the both end tab of FPC get over the housing boss.

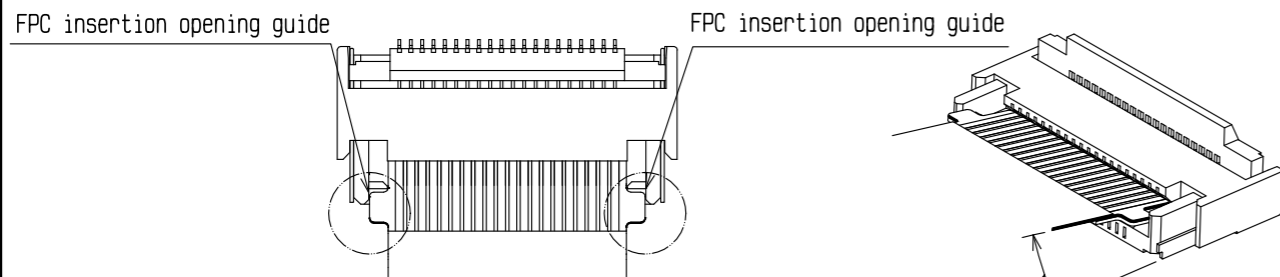

Insertion: 10°  
Removal: Angle of the FPC tabs must get over the housing.

**X NG**

Insertion and removal with actuator close

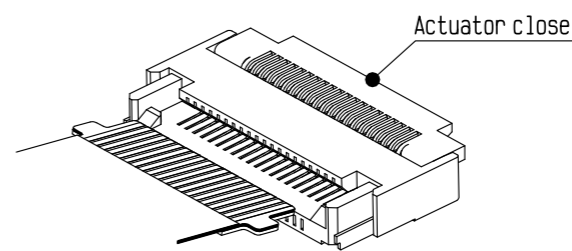

**X NG**

Insertion and removal during wrenching up, down, left and right.

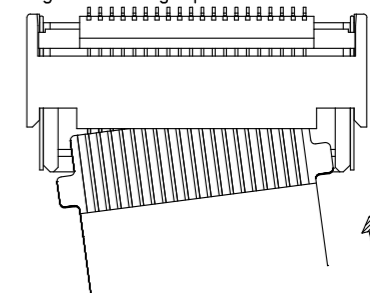

**X NG**

Insertion and removal excessive angles from PCB surface

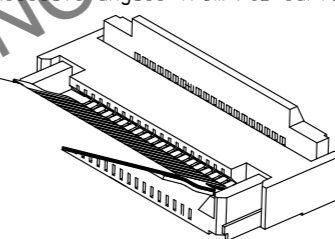

**X NG**

Insertion and removal horizontal angle from PCB surface

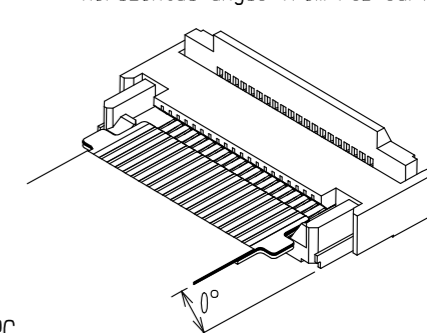

3. FPC insertion check and mating confirmation of the FPC  
Guide for positioning FPC guide the FPC tabs to the correct position. Make sure that the FPC tabs are located in correct position as shown in the figure below after FPC insertion and mating.

**OK**

FPC(Proper position)

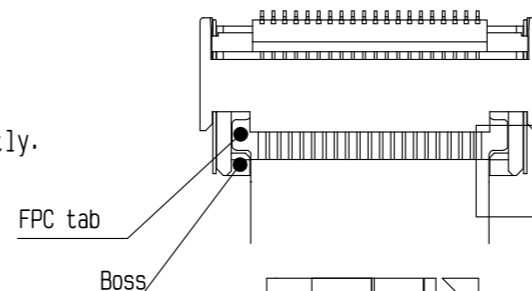

**X NG**

FPC(shallow Position)

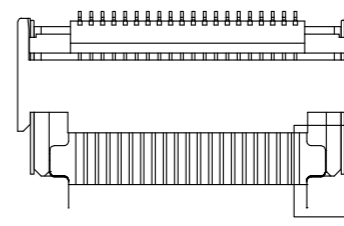

**X NG**

FPC(Slanted)

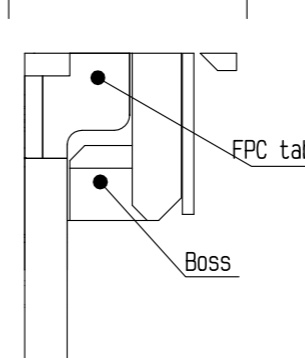
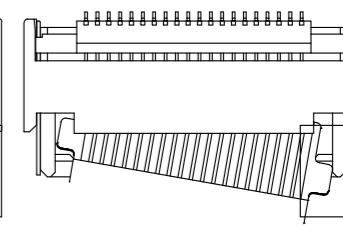

FPC tab rides on boss

<INSTRUCTION MANUAL (1)>

<b>HRS</b>	DRAWING NO.	EDC-392112-00-00	5/8
	PART NO.	FH69-***S-0.5SH	
	CODE NO.	CL580	

Jul.1.2024 Copyright 2024 HIROSE ELECTRIC CO., LTD. All Rights Reserved.  
 In case of consideration for using Automotive equipment / device which demand high reliability, kindly contact our sales window correspondents.

4. How to lock and unlock

The actuator rotates around the rotational axis.

Lock : Apply load to rotate the actuator by 90 degree after inserting the FPC.

Unlock : Slowly flip up the Actuator lock

OK

How to lock

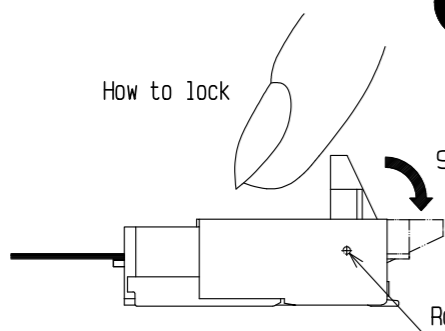

90°

How to unlock

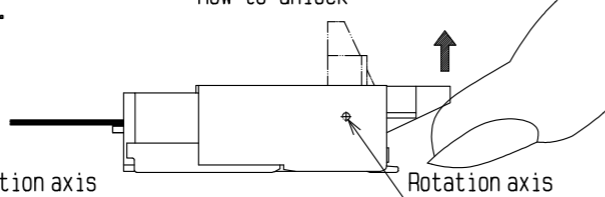

Rotation axis

Rotation axis

OK

Operate the center of the actuator

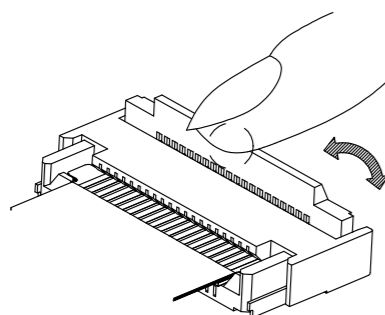

X NG

Operate near both-ends of the actuator at the same timing moment.  
 (Around 3 PIN from the end)

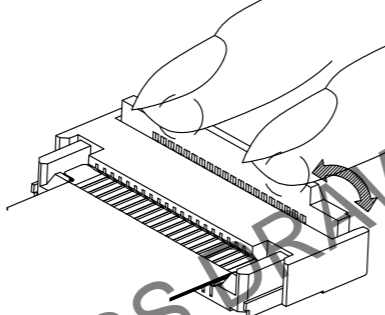

X NG

Operate at one end of the actuator

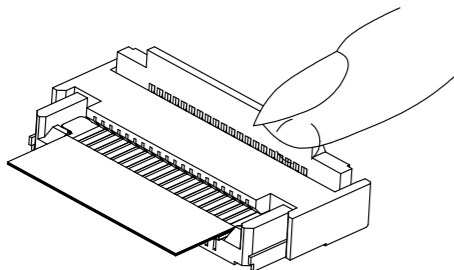

Force from reverse direction to actuator.

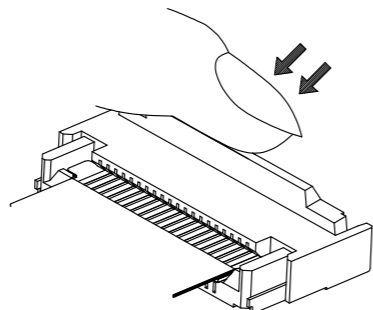

X NG

Push horizontally to lock

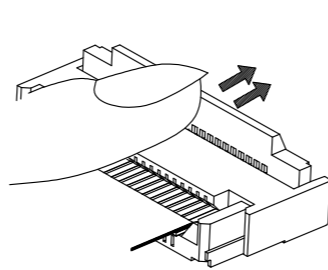

X NG

Push vertical to lock

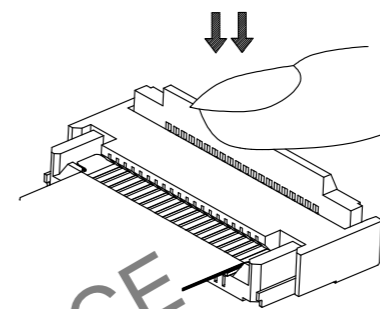

X NG

Pick the actuator to lift

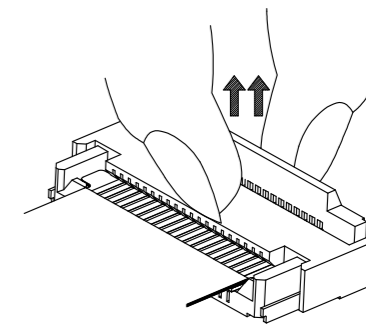

X NG

Operate with a sharp tool

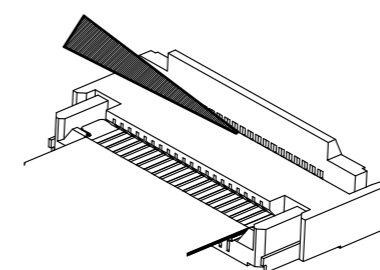

X NG

Operation to push the actuator into connector

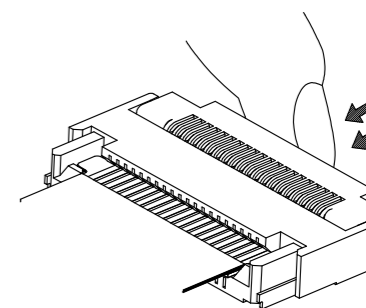

X NG

Excessive force to housing

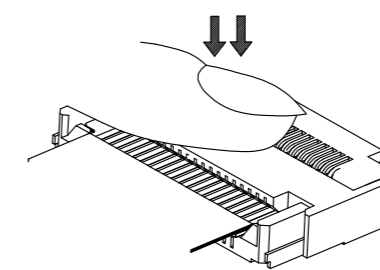

X NG

Operation from FPC insertion opening side

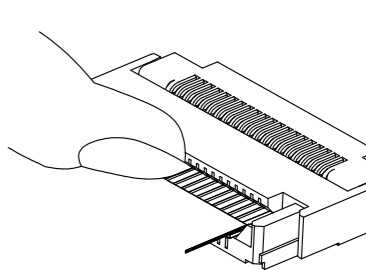

<INSTRUCTION MANUAL (2)>

<b>HRS</b>	DRAWING NO.	EDC-392112-00-00
	PART NO.	FH69-**S-0.5SH
	CODE NO.	CL580
	6/8	

Jul.1.2024 Copyright 2024 HIROSE ELECTRIC CO., LTD. All Rights Reserved.  
In case of consideration for using Automotive equipment / device which demand high reliability, kindly contact our sales window correspondents.

[Instructions for PCB layout]

Please design a PCB layout not to apply load to connector and FPC.

[Cautions]

- If the FPC has to be curled/bended in your cabling design, please keep enough degree of freedom in your design to keep the FPC tension free. In this regard, the stiffener is parallel to the PCB.
- Do not mount other components underneath the FPC stiffener which may interfere with the connection.
- Please consult with the FPC manufacturer about FPC bending performance and wire breakage strength while making design.
- Keep enough space for the rotation of the actuator during PCB and component layout design.
- Please consult with our sales representative if you are using FPC with different configuration from our recommendation.

OK

No load applied to stiffener

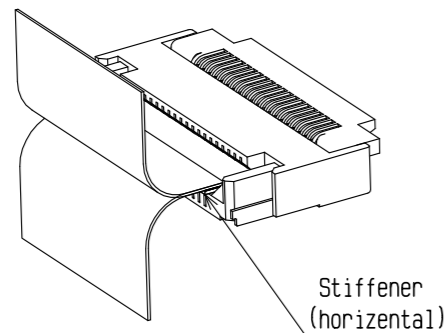

Stiffener (horizontal)

NG

Load applied to stiffener

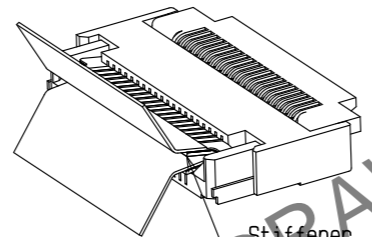

Stiffener (Diagonally)

NG

Load applied to FPC

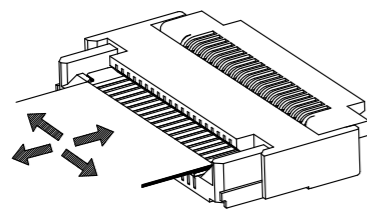

NG

Housing or parts interfering with the FPC

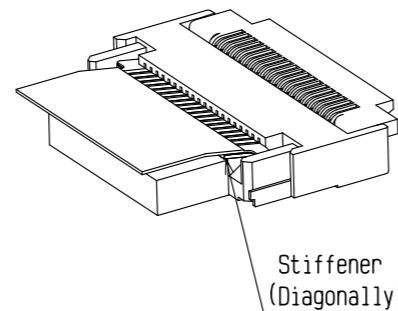

Stiffener (Diagonally)

[Instructions for mounting on the PCB]

- Refer to recommended layouts for PCB, stencil pattern and FPC dimension. Please inspect the size of solder fillet and flux climbing height of the mounted connector while using different land/stencil pattern from our recommendation.
- Please verify your solder resist/silk screening design carefully before implementing the design.
- Apply reflow temperature profile within the specified conditions. For specific applications, the recommended temperature may vary depending on type/volume/thickness of solder paste and size/thickness of PCB. Please consult with your solder paste and equipment manufacturer for specific recommendations.
- Please try to minimize the warpage of the PCB. Soldering failure could still occur due to the PCB warpage even if the coplanarity of the connector is under 0.1mm.
- If the connector is mounting on FPC, please make sure to put a stiffener on the backside of the FPC. Recommended stiffener: Glass epoxy material with thickness of 0.3mm MIN.
- Do not apply 0.5N or greater external force on the connector when unreeling or handling the connector before mounting. Excessive mechanical stress may damage the connector before mounting.

[Instructions for PCB handling after mounting the connector]

The warpage of PCB may apply excessive stress on the connector and damage the connector.

- Splitting a large PCB into several pieces
  - Installing mounting screw on PCB
- During the assembly processes described above, care shall be taken so as not to give any stresses of deflection or twisting to the PCB.
- The warpage of a 100mm wide PCB should remain within 0.5mm.

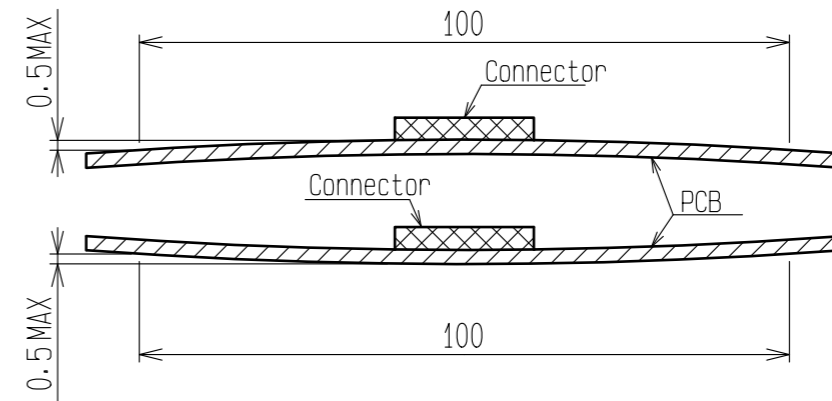

[Instructions of hand soldering]

- Do not perform hand soldering with the FPC inserted into the connector.
- Do not apply excessive heat. And soldering iron must not touch connector except terminal leads area.
- Do not supply excessive solder (flux).

<INSTRUCTION MANUAL (3)>

<b>HRS</b>	DRAWING NO.	EDC-392112-00-00
	PART NO.	FH69-**S-0.5SH
	CODE NO.	CL580
		7/8

Jul.1.2024 Copyright 2024 HIROSE ELECTRIC CO., LTD. All Rights Reserved.  
In case of consideration for using Automotive equipment / device which demand high reliability, kindly contact our sales window correspondents.

[Recommended reflow temperature profile]

The temperatures mentioned above refer to the PCB surface temperature near the connector leads.  
For specific applications, the recommended temperature may vary depending on type/volume/thickness of solder paste and size/thickness of PCB.  
Please consult with your solder paste and equipment manufacturer for specific recommendations.

- Reflow method:IR reflow
- Number of reflow cycles:2 cycles MAX.

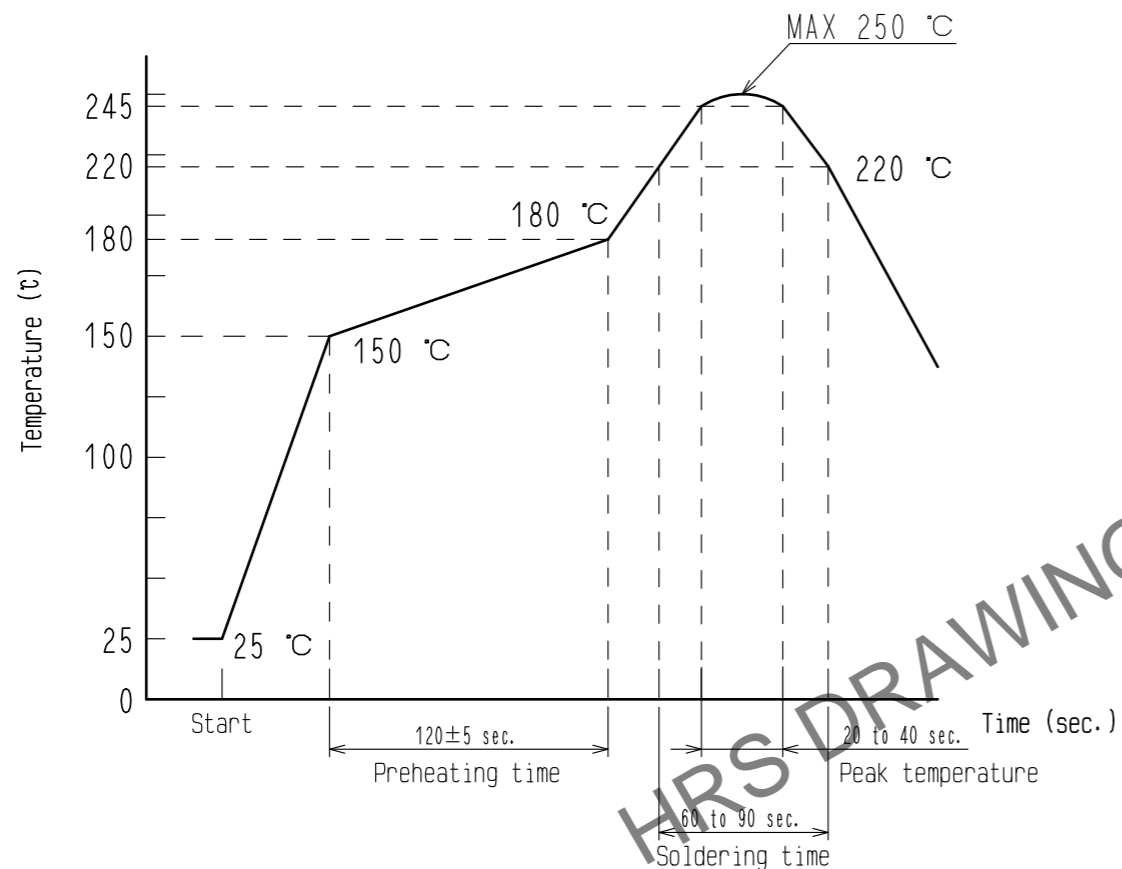

HRS DRAWING FOR REFERENCE

<INSTRUCTION MANUAL (4)>

<b>HRS</b>	DRAWING NO.	EDC-392112-00-00
	PART NO.	FH69-**S-0.5SH
	CODE NO.	CL580

2/8