

Jan.1.2025 Copyright 2025 HIROSE ELECTRIC CO., LTD. All Rights Reserved.  
In case of consideration for using Automotive equipment / device which demand high reliability, kindly contact our sales window correspondents.

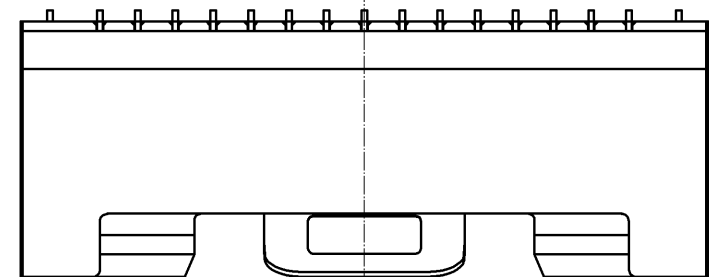

A (10:1)

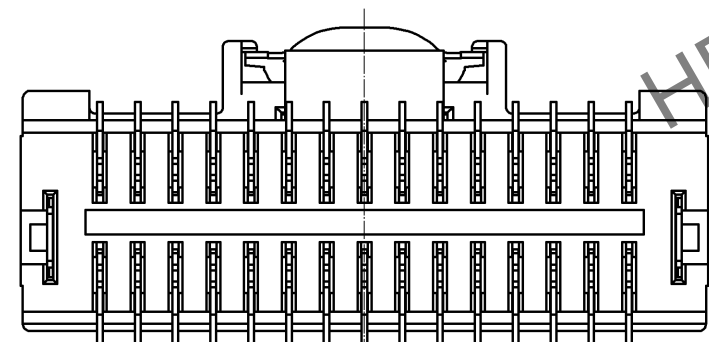
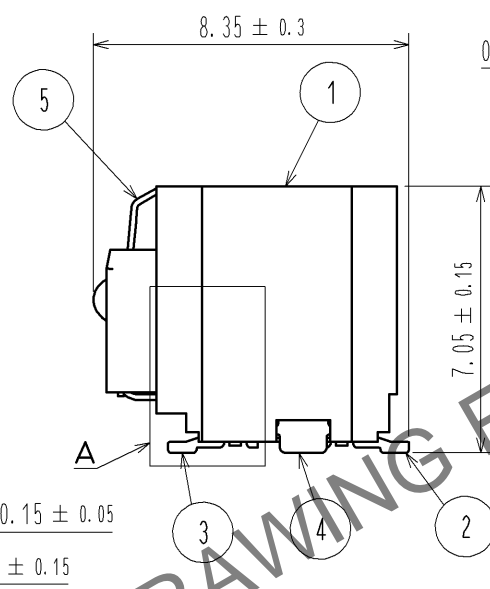
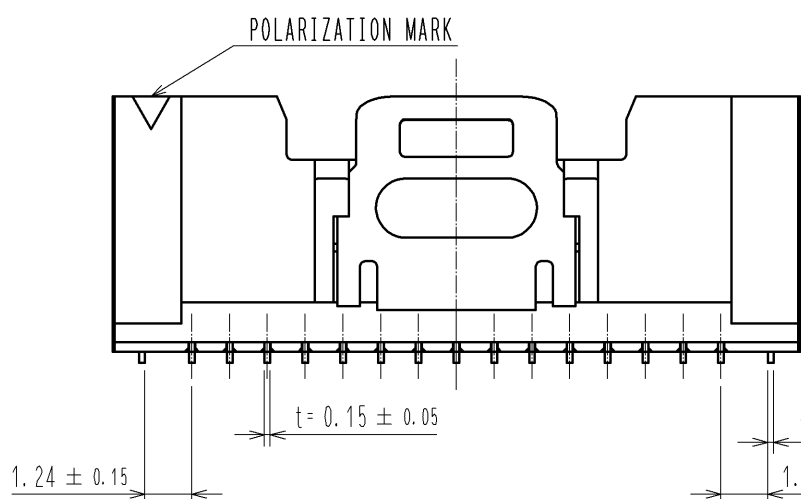
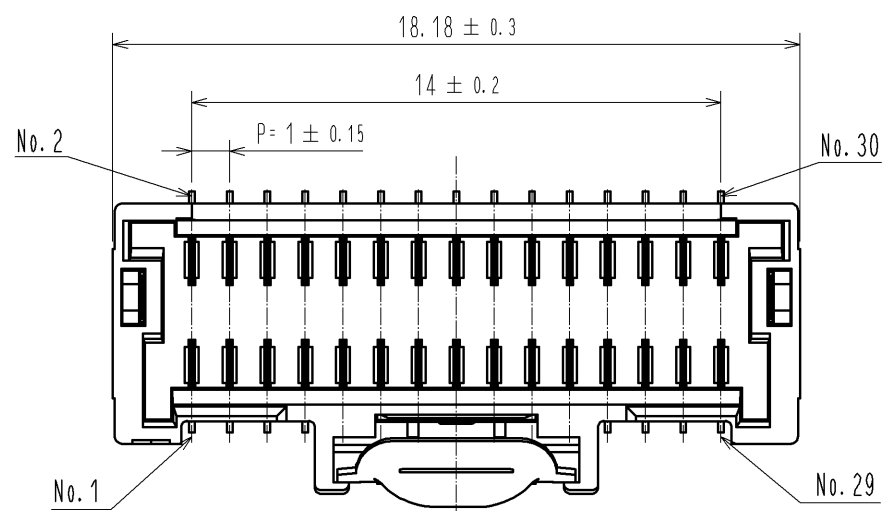
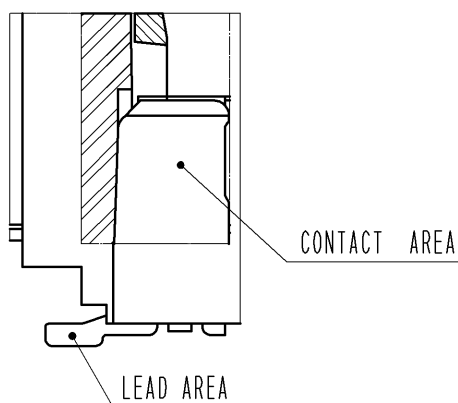

RECOMMENDED PCB LAYOUT (MOUNTING SURFACE SIDE) (FREE)

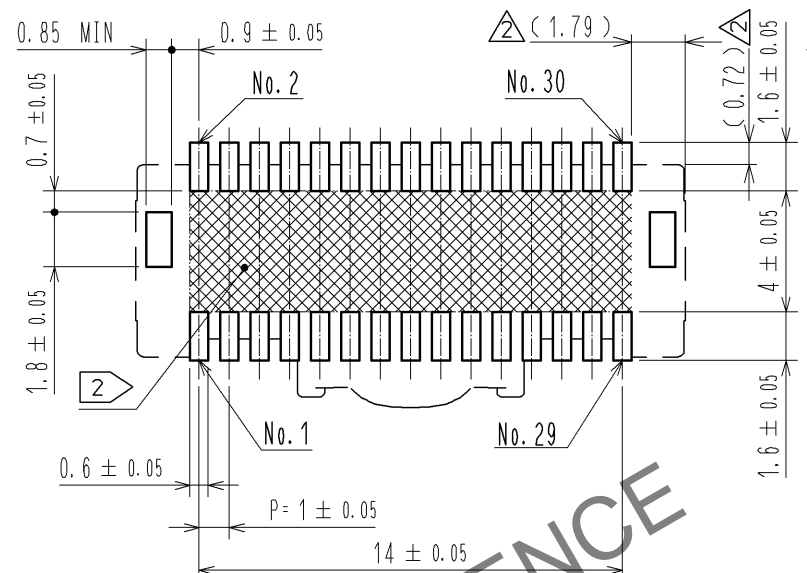

RECOMMENDED METAL MASK (FREE) THICKNESS : 0.1mm

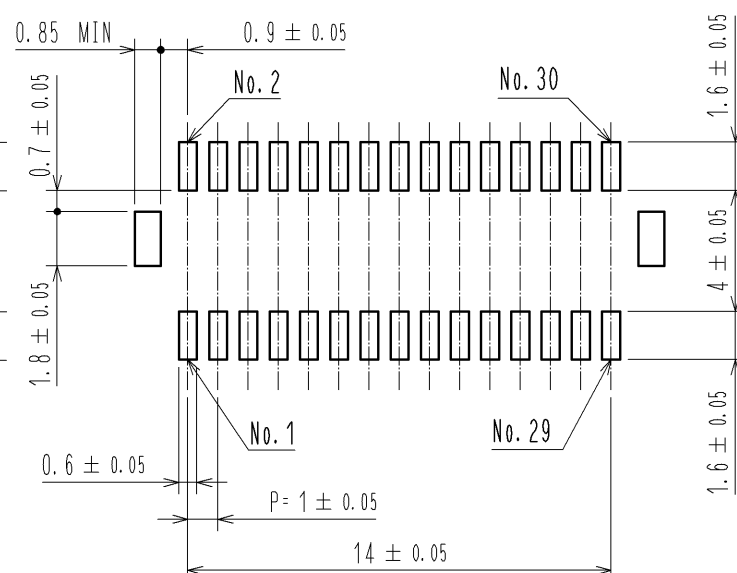

MATING FIGURE (5:1)

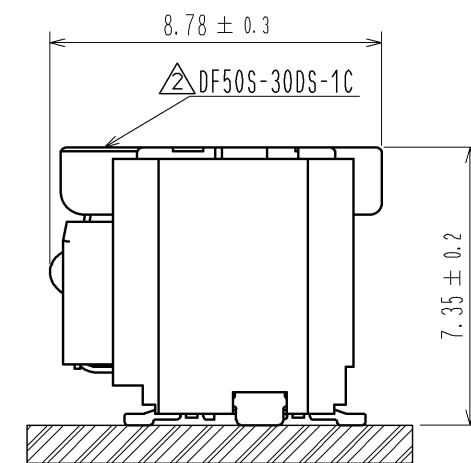
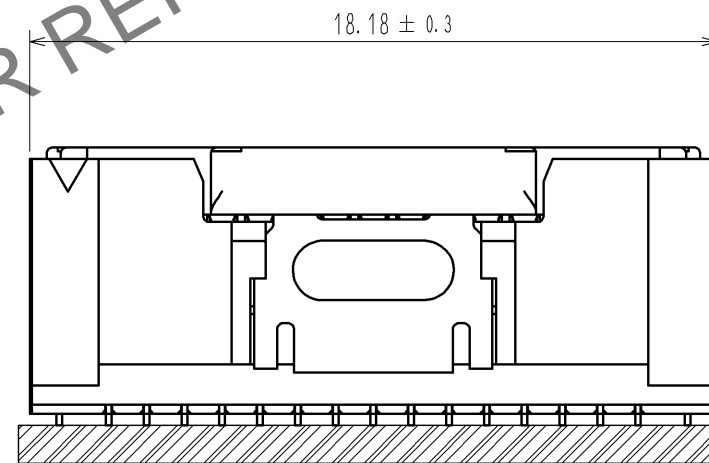

- NOTES 1. LEAD CO-PLANARITY SHALL BE 0.1mm MAX  
 2. Hatched area indicated must be free of conductive traces or the conductive traces must be covered by resist film.  
 3. PLEASE CONSULT HIROSE WHEN THE PRODUCT IS MOUNTED TO FPC.

3	BRASS	CONTACT AREA : Au PLATING 0.05μm MIN LEAD AREA : Au PLATING 0.05μm MIN UNDER PLATING : Ni PLATING 1μm MIN	8	PS	REEL , BLACK
2	BRASS	CONTACT AREA : Au PLATING 0.05μm MIN LEAD AREA : Au PLATING 0.05μm MIN UNDER PLATING : Ni PLATING 1μm MIN	7	POLYESTER	CLEAR
1	LCP	BLACK , UL94V-0	6	PS	CLEAR
			5	STAINLESS STEEL	—
			4	BRASS	CONTACT AREA : Sn PLATING 1μm MIN UNDER PLATING : Ni PLATING 0.5μm MIN
NO.	MATERIAL	FINISH , REMARKS	NO.	MATERIAL	FINISH , REMARKS

UNITS mm		SCALE FREE	COUNT 5	DESCRIPTION OF REVISIONS DIS-H-007735	DESIGNED MI. SAKIMURA	CHECKED TS. KUMAZAWA	DATE 13.03.22
<b>HRS</b> HIROSE ELECTRIC CO., LTD.		APPROVED : TS. SAKATA	09.12.04	DRAWING NO. EDC3-320002-01			
		CHECKED : MN. KENJO	09.12.04	PART NO. DF50-30DP-1V(51)			
		DESIGNED : TT. OHSAKO	09.12.04	CODE NO. CL665-0001-8-51			
		DRAWN : TT. OHSAKO	09.12.04				

Jan.1.2025 Copyright 2025 HIROSE ELECTRIC CO., LTD. All Rights Reserved.  
In case of consideration for using Automotive equipment / device which demand high reliability, kindly contact our sales window correspondents.

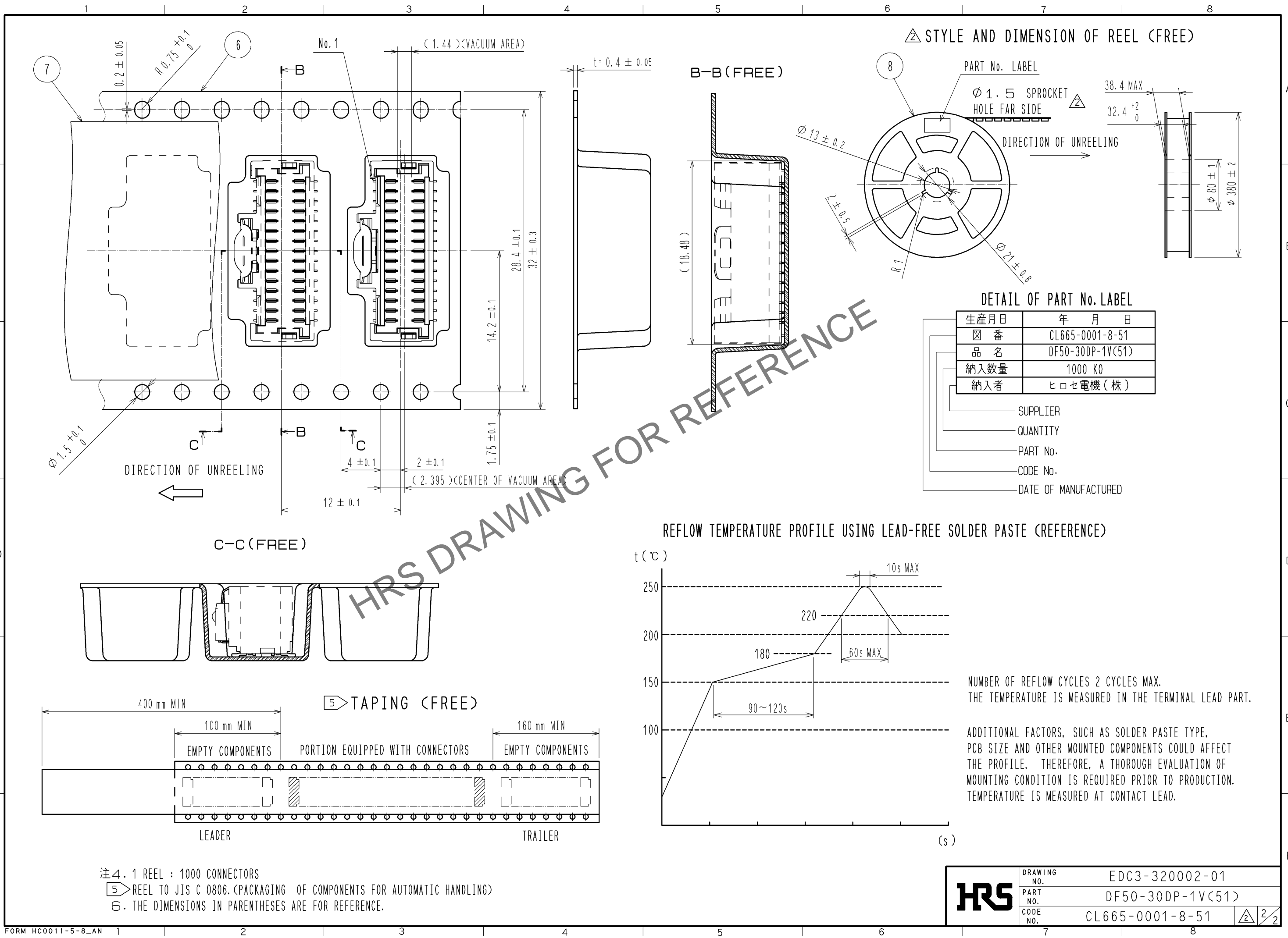

<b>HRS</b>	DRAWING NO.	EDC3-320002-01
	PART NO.	DF50-30DP-1V(51)
	CODE NO.	CL665-0001-8-51
		2/2