

Jan.1.2025 Copyright 2025 HIROSE ELECTRIC CO., LTD. All Rights Reserved.
In case of consideration for using Automotive equipment / device which demand high reliability, kindly contact our sales window correspondents.

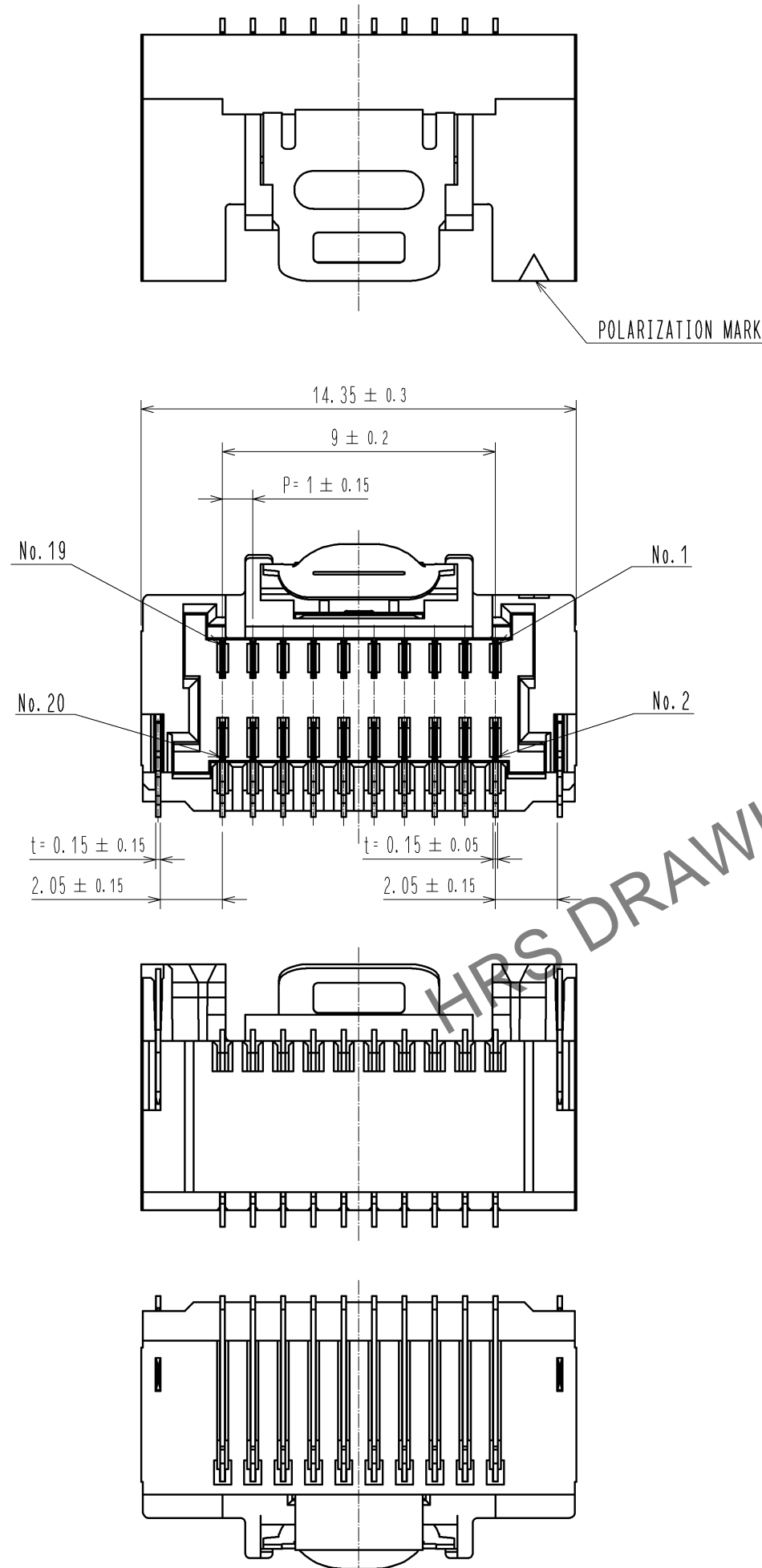

HRS DRAWING FOR REFERENCE

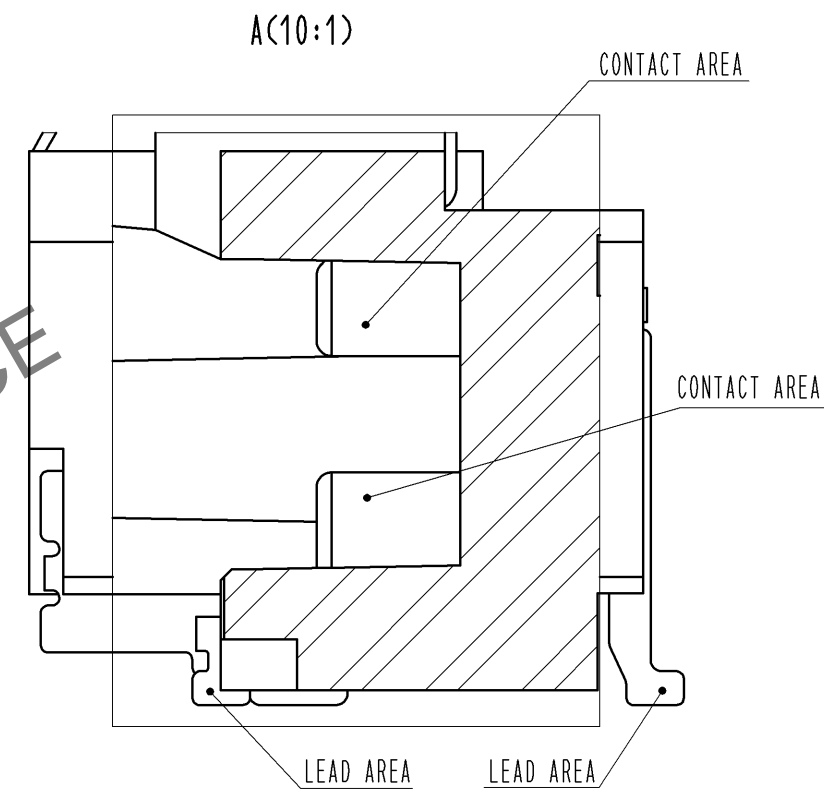

- NOTE 1. LEAD CO-PLANARITY SHALL BE 0.1mm MAX
 2. (DELETED)
 TRACES OR THE CONDUCTIVE TRACES MUST BE COVERED BY RESIST FILM.
 3. PLEASE CONSULT HIROSE WHEN THE PRODUCT IS MONITED TO FPC.

3	BRASS	CONTACT AREA : Au PLATING 0.05 μm MIN LEAD AREA : Au PLATING 0.05 μm MIN UNDER PLATING : Ni PLATING 1 μm MIN	8	PS	REEL, BLACK
2	BRASS	CONTACT AREA : Au PLATING 0.05 μm MIN LEAD AREA : Au PLATING 0.05 μm MIN UNDER PLATING : Ni PLATING 1 μm MIN	7	POLYESTER	CLEAR
1	LCP	BLACK, UL94V-0	6	PS	CLEAR
			5	STAINLESS STEEL	—
			4	BRASS	CONTACT AREA : Sn PLATING 1 μm MIN UNDER PLATING : Ni PLATING 0.5 μm MIN
NO.	MATERIAL	FINISH, REMARKS	NO.	MATERIAL	FINISH, REMARKS
UNITS mm		SCALE 5 : 1	COUNT 2	DESCRIPTION OF REVISIONS DIS-H-008701	
DESIGNED MI. SAKIMURA			CHECKED TS. KUMAZAWA		
DATE 14. 04. 22			DRAWING NO. EDC3-332132-01		
APPROVED : KI. AKIYAMA 11. 12. 26			PART NO. DF50-20DP-1H(51)		
CHECED : OM. MIYAMOTO 11. 12. 26			CODE NO. CL665-0016-5-51		
DESIGNED : TT. OHSAKO 11. 12. 01					
DRAWN : TT. OHSAKO 11. 12. 01			1/3		

Jan.1.2025 Copyright 2025 HIROSE ELECTRIC CO., LTD. All Rights Reserved.
 In case of consideration for using Automotive equipment / device which demand high reliability, kindly contact our sales window correspondents.

RECOMMENDED PCB LAYOUT
 (MOUNTING SURFACE SIDE) (FREE)

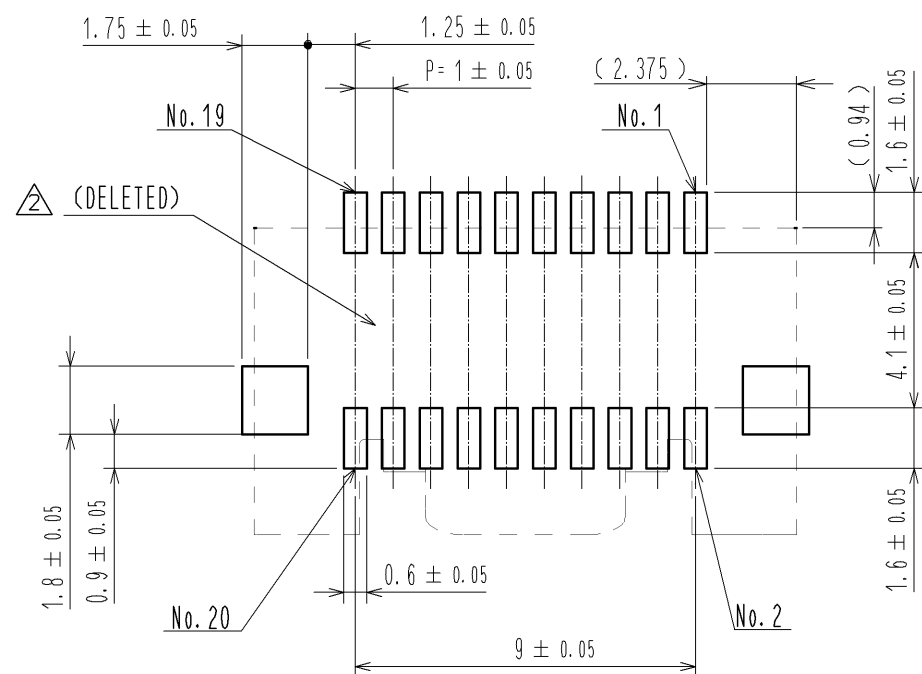

RECOMMENDED METAL MASK (FREE)

THICKNESS : 0.1mm
 OPEN AREA RATIO:100%

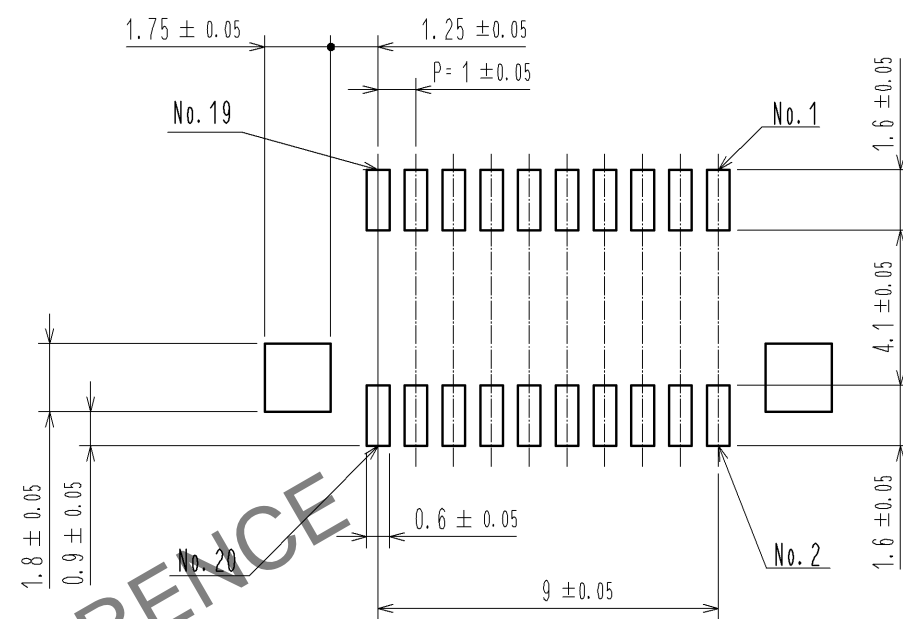

MATING FIGURE (5 : 1)

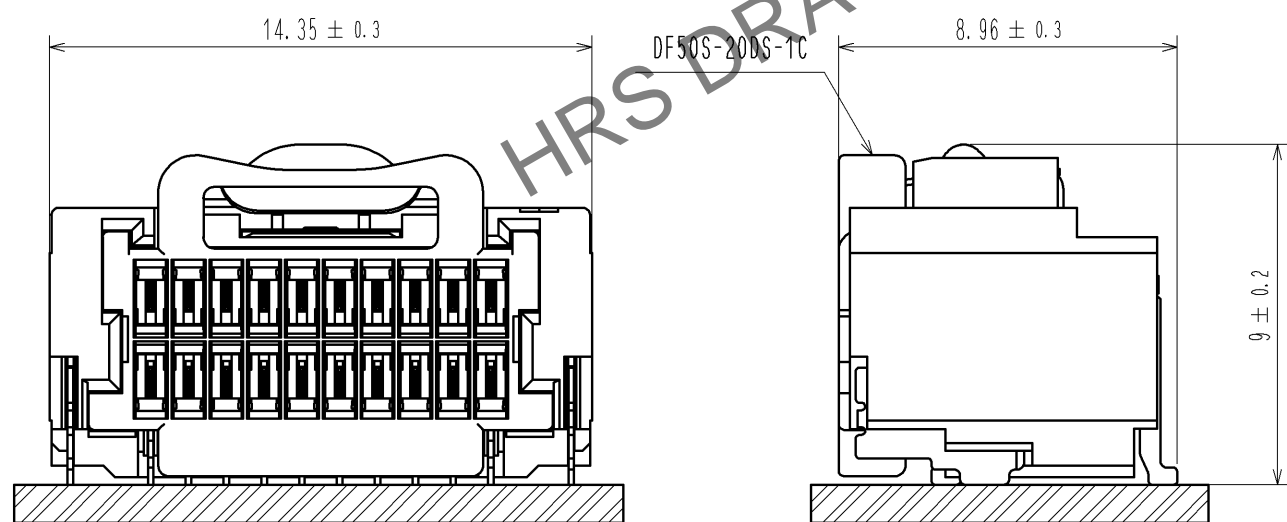

REFLOW TEMPERATURE PROFILE USING LEAD-FREE SOLDER PASTE (REFERENCE)

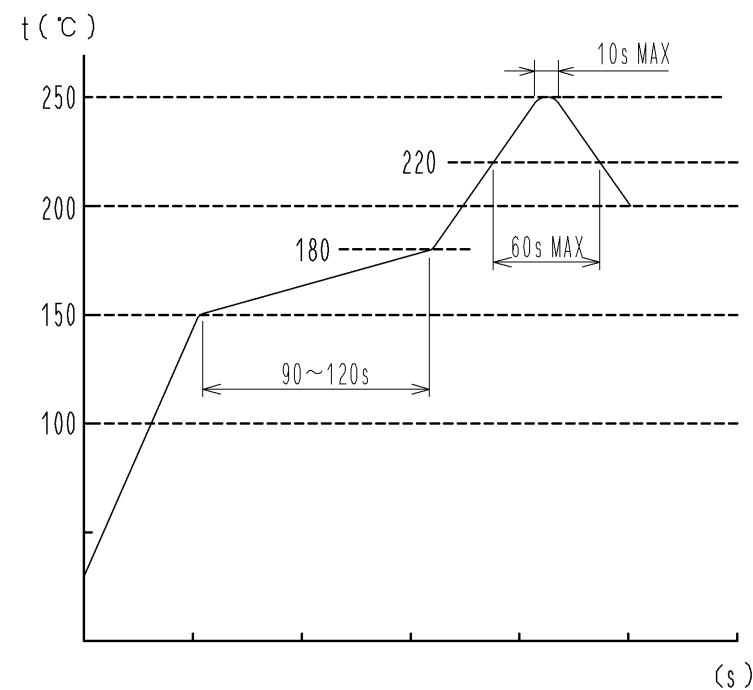

NUMBER OF REFLOW CYCLES: 2 CYCLES MAX.
 THE TEMPERATURE OF THIS PROFILE IS MEASURED ON THE LEAD TERMINAL.

WE RECOMMEND PERFORMING AN EVALUATION UNDER THE MOUNTING CONDITIONS YOU WILL BE USING BECAUSE IT COULD BE AFFECTED BY ANY CONDITION:TYPE OF SOLDER PASTE, SIZE OF PCB, MOUNTING MATERIAL etc..

HRS	DRAWING NO.	EDC3-332132-01
	PART NO.	DF50-20DP-1H(51)
	CODE NO.	CL665-0016-5-51
		2/3

Jan.1.2025 Copyright 2025 HIROSE ELECTRIC CO., LTD. All Rights Reserved.
 In case of consideration for using Automotive equipment / device which demand high reliability, kindly contact our sales window correspondents.

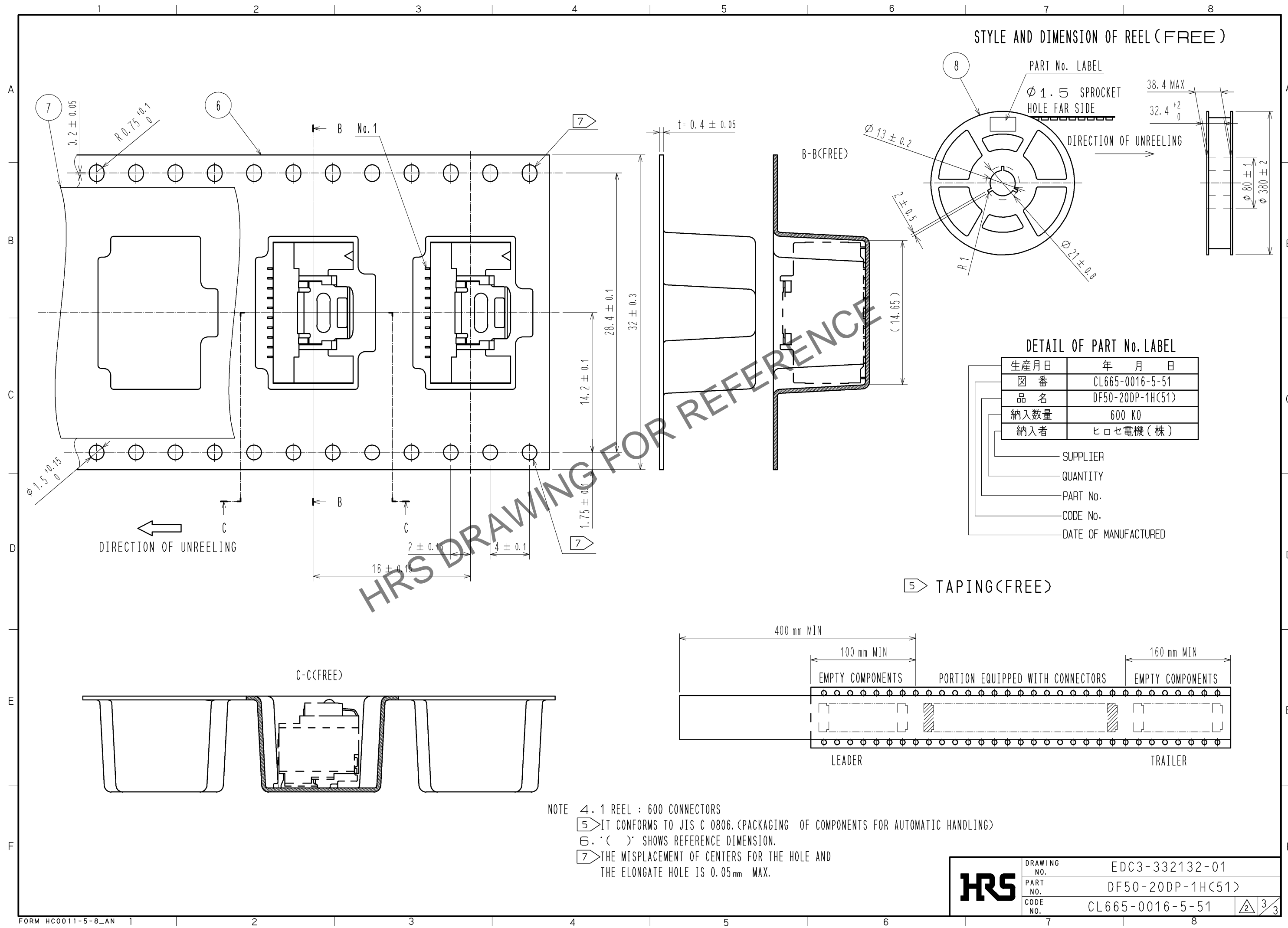

HRS	DRAWING NO.	EDC3-332132-01
	PART NO.	DF50-20DP-1H(51)
	CODE NO.	CL665-0016-5-51
		3/3