

1. Scope

This document specifies the process from crimping the DF60-series crimped terminals to cables to inserting the terminals to crimping sockets and in-line plugs.

2. Process for harnessing

2.1. Cable stripping

Strip cables in accordance with Crimping Quality Standards (ETAD-H0519/0647/0747/0797/1042).



In so doing, make sure there is no scratch on cable cores.

2.2. Crimping

Crimp terminals to cables using an applicator (AP105-DF60-8 or AP105-DF60-1012 or AP105-DF60S-8S or AP105-DF60S-1012S),

and check the crimping height and shape in accordance with the Table of crimping conditions and Crimping Quality Standards (ETAD-H0519/0647/0747/0797/1042).

In the case of using a cabtyre cable, etc., perform crimping so that the terminal insertion direction is correct when it is inserted into the crimping socket.

	COUNT	DESCRIPTION OF REVISIONS	DESIGNED	CHECKED	DATE
	1	DIS-H-00023960	TS. KUMAZAWA	SZ. ONO	20250728
TITLE DF60 Series Cable Assembly Procedure			 HIROSE ELECTRIC CO., LTD.		
			APPROVED	TS. FUKUSHIMA	20150326
			CHECKED	TS. FUKUSHIMA	20150326
			DESIGNED	TS. KUMAZAWA	20150325
			WRITTEN	TS. KUMAZAWA	20150325
TECHICAL SPECIFICATION			ETAD-H0653-00		 1/12

*DF60F (finger protection type)

To support finger protection, attach the heat-shrinkable tube.

However, when using DF60S-8SC(F)A(##), heat-shrinkable tube is optional.

◆ Specification of heat-shrinkable tube

- Target crimp terminal : DF60-8SC(F)A(##), DF60-1012SC(F)A(##)
DF60-8PC(F)A(##), DF60-1012PC(F)A(##)

Name of product	Before shrinkage (mm)		After shrinkage (mm)		Rated voltage (V)	Rated temperature (°C)
	Inside diameter	Thickness	Inside diameter	Thickness		
SUMITUBE F2(Z) 8X0.25	Φ 8.4±0.4	0.25	Φ 4.0	0.56	600	125

- Target crimp terminal : DF60S-8SC(F)A(##), DF60S-1012SC(F)A(##)

When installing a tube after crimping, the recommended tube differs for each cable size only for the right-angle type. The recommended tube differs for each cable size only for the right-angle type. Please see below.

	Name of product	Before shrinkage (mm)		After shrinkage (mm)		Rated voltage (V)	Rated temperature (°C)
		Inner diameter	Thickness	Inner diameter	Thickness		
AWG8-12 (Before crimping)	SUMITUBE F2(Z) 8X0.25	Φ 8.4±0.4	0.25	Φ 4.0	0.56	600	125
AWG8 (After crimping)	SUMITUBE F4(Z) 1/2inch	Φ 13.2±0.5	0.15	Φ 6.4	0.28	300	125
AWG10-12 (After crimping)	SUMITUBE F2(Z) 14X0.3	Φ 14.5±0.4	0.30	Φ 7.0	0.69	600	125

*If the recommended tube cannot be used, select the tube that meets the following requirements.

Rated temperature: 105°C or more

Inner diameter before shrinkage: Recommended tube or higher

Inner diameter after shrinkage: Less than or equal to the outer diameter of the sheath of the cable to be used

Thickness after shrinkage: Below recommended tube

<Procedure for attaching tube>

(1) Cut the tube (to a length of 10 mm to 15 mm)

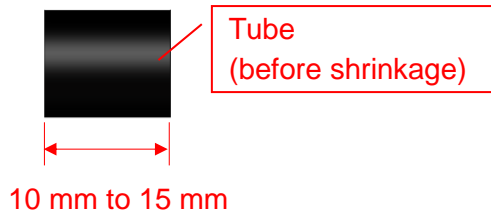

(2) Thread the tube from the tip of the crimp terminal.

Straight type

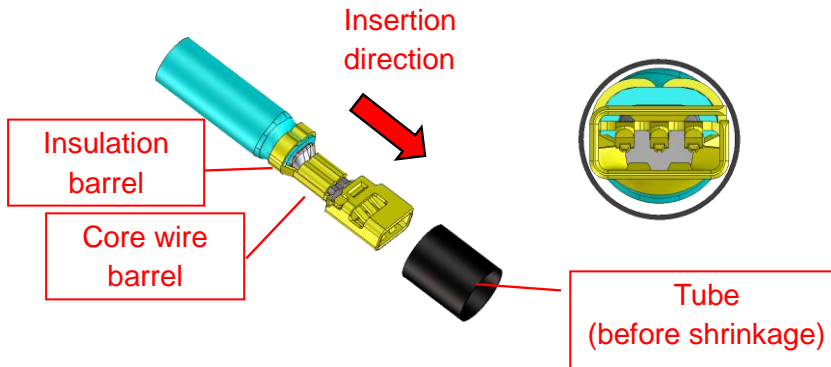

Right angle Type

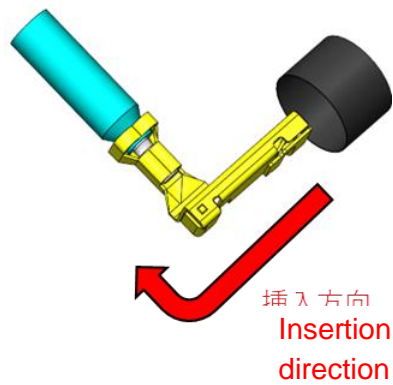

(3) Adjust the position of the tube tip to the range shown in the figure below.

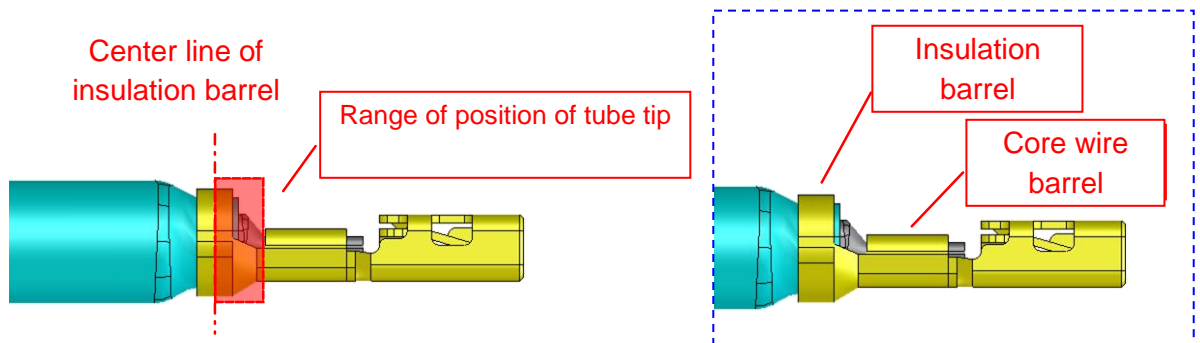

(4) Apply heat to the tube to shrink it (completion).

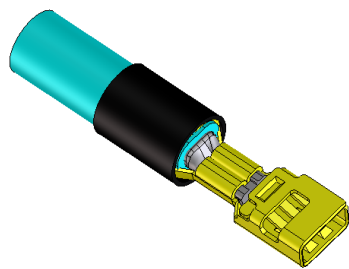
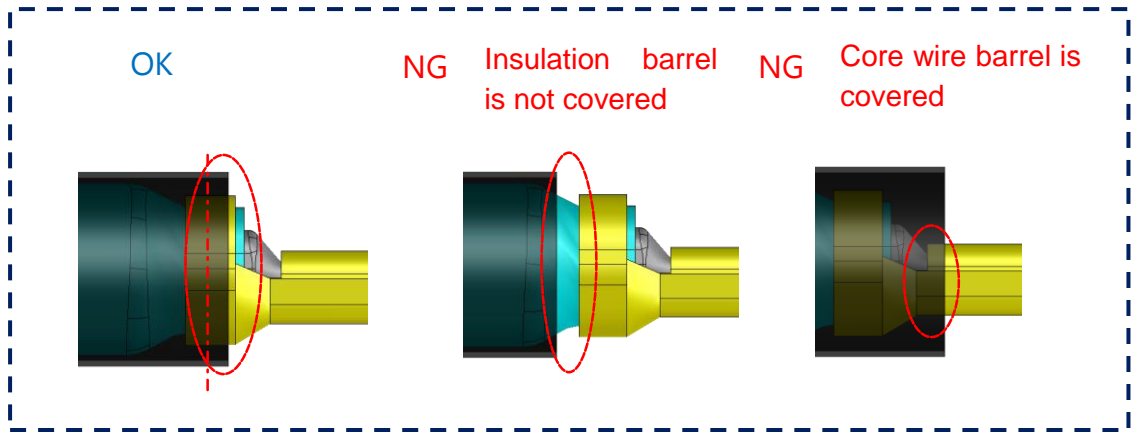

Crimped terminal for socket

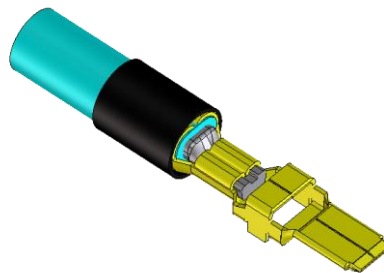

Crimped terminal for plug

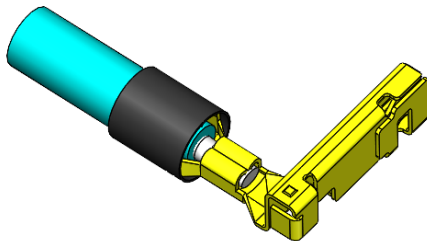

Crimped terminal for right angle socket

2.3. Insert crimped terminal to socket

Hold the cable of a crimped terminal, and insert it to each terminal hole of crimping sockets and inline plugs.

*The figures show insertion to DF60-3S-10.16C and DF60-3EP-10.16C.

For insertion, place the crimped terminal lance and crimping case lock in the following direction:

Crimping socket

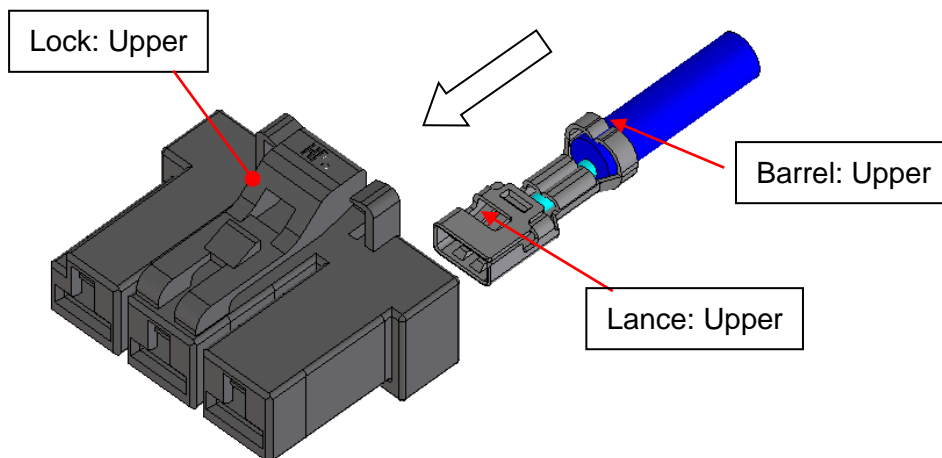

Inline plug

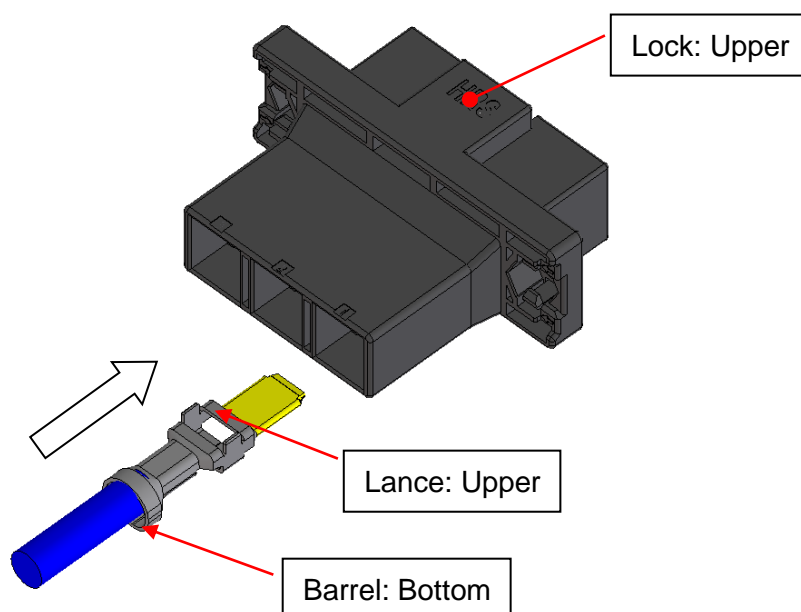

Crimp Socket (Right angle type)

When using the right-angle type, attach the cover case after inserting the terminals.

*Figure is for DF60FS-2S-10.16C.

(1) Terminal insertion

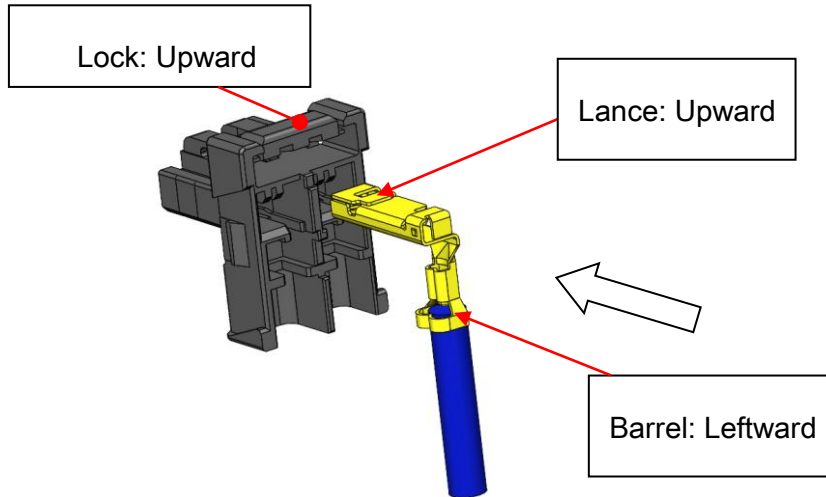

(2) Cover case installed

Push in both ends of the cover case with both hands and insert until you hear a "click" sound.

*If only the center portion is pressed in, the insertion may be insufficient.

Be sure to push in both ends.

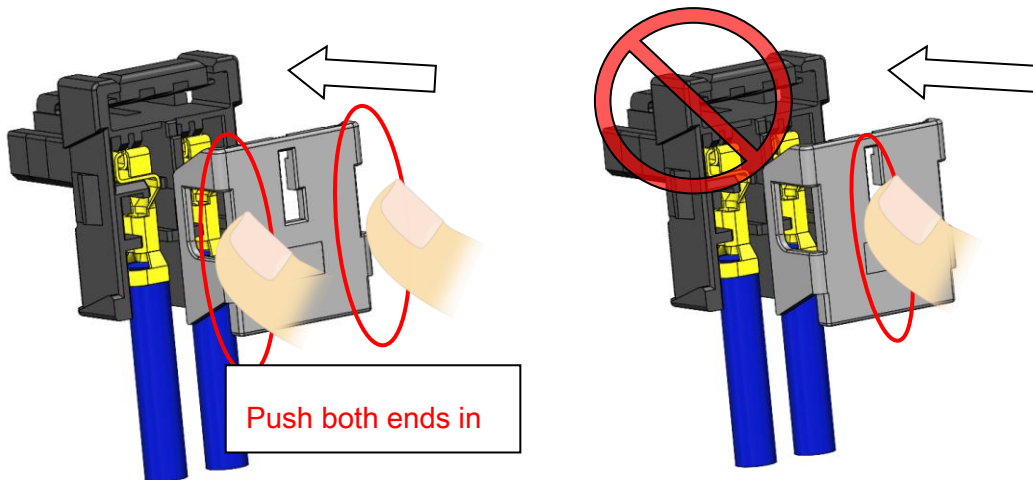

⚠ (3) Confirmation of installation

Make sure that the locks on both sides are securely engaged.

*Repair work is prohibited on cover cases as it may reduce their strength.

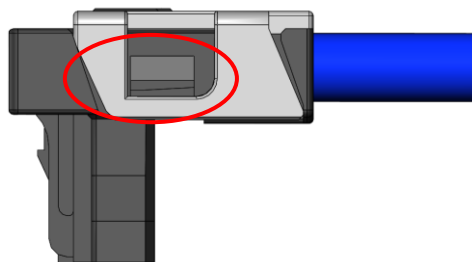

- See below for the terminal numbers of crimping cases and inline plugs:

Crimping socket (Straight type)

Terminal No.1

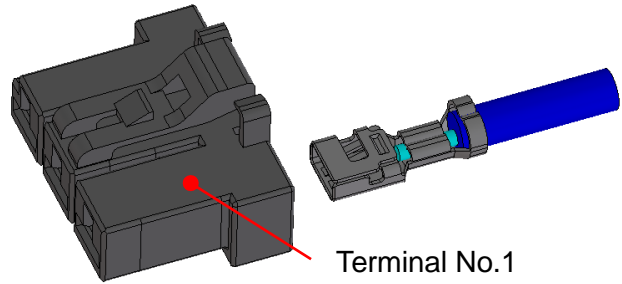
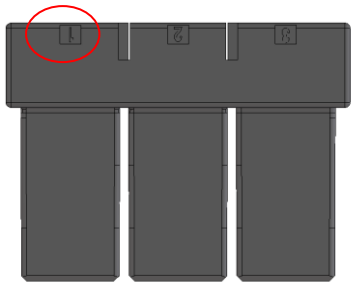

Crimping socket (Right angle type)

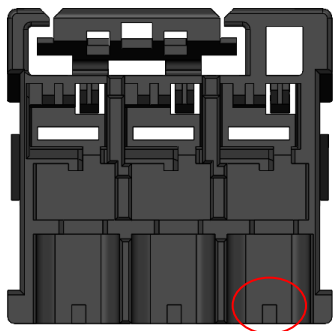

Terminal No.1

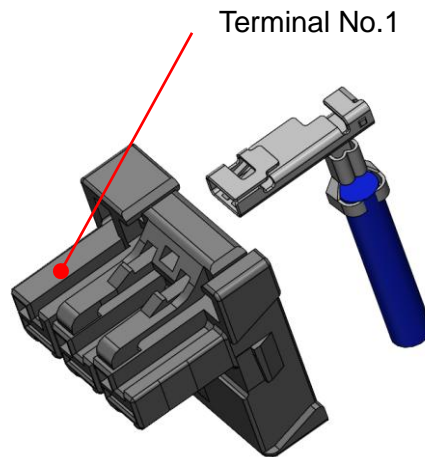

Inline plug

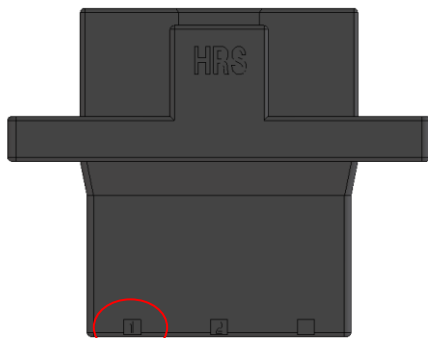

Terminal No.1

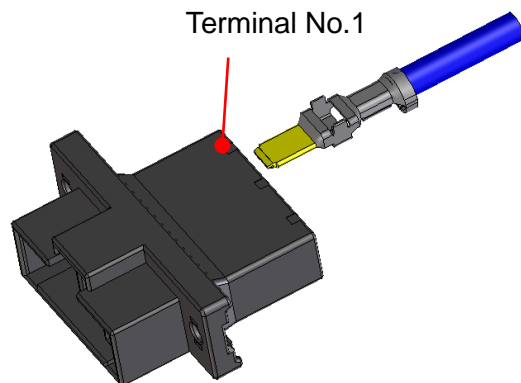

- How to insert cables into multipole terminal

The insertion of cables in a bended state allows users to carry out the operation without any difficulty as shown in the drawing below.

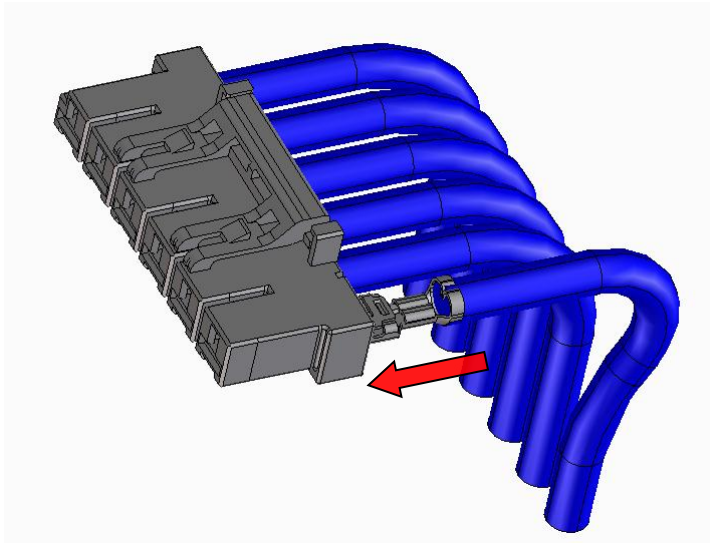

- To maintain performance reliability, do not tilt crimped terminals for insertion.

Horizontal insertion : OK

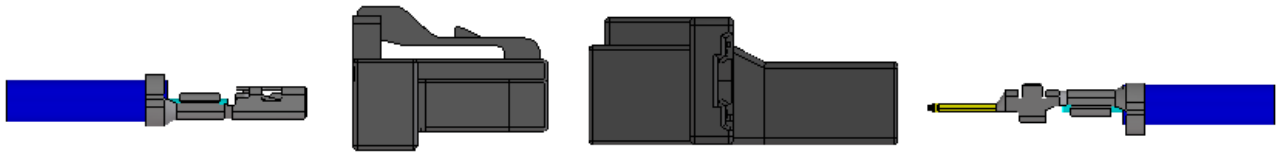

Tilted insertion : NG

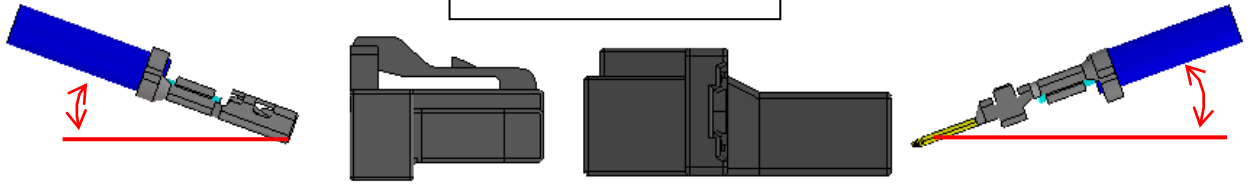

Twisted insertion : NG

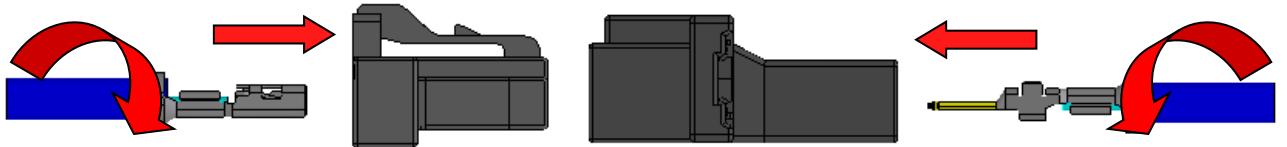

Horizontal insertion : OK

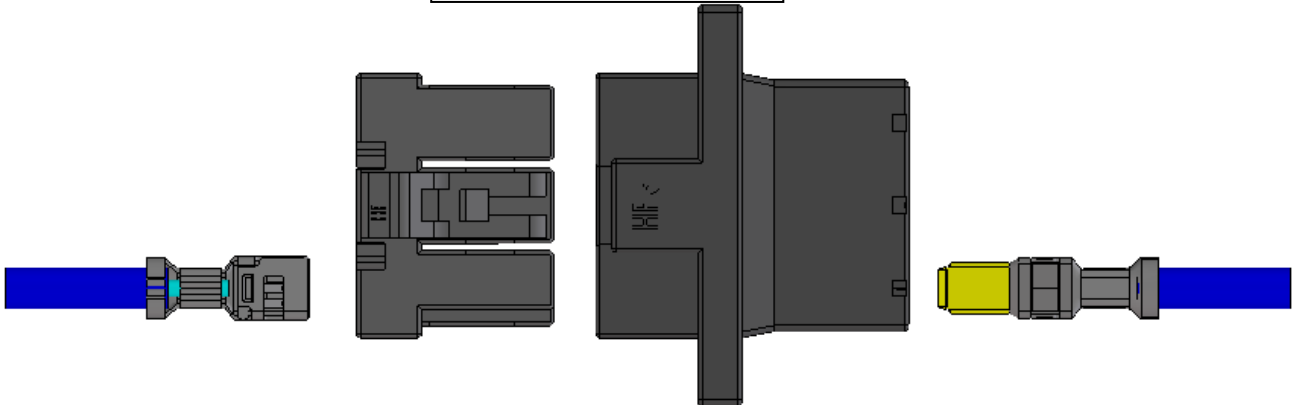

Tilted insertion : NG

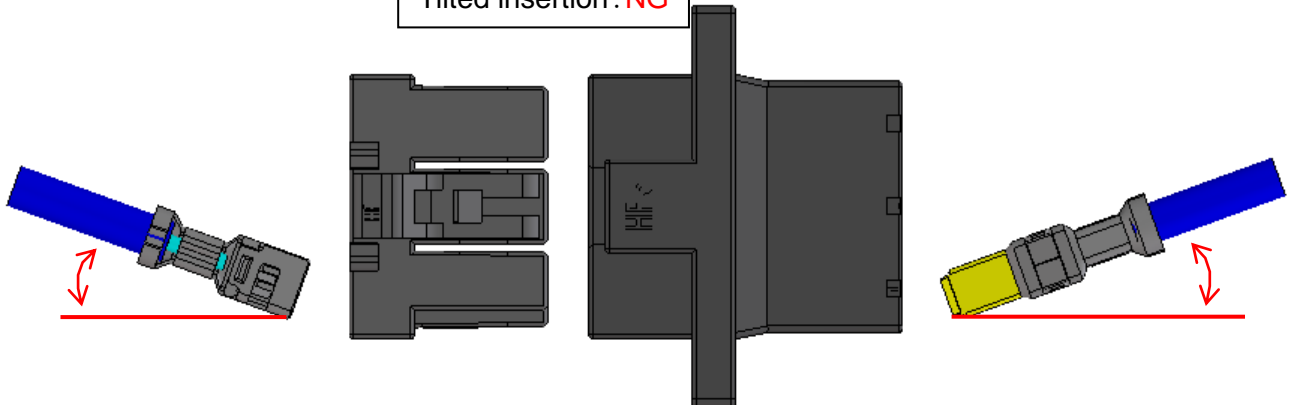

2.4. Check how the terminals have been inserted

- Check that the lance of a crimped terminal has been caught at the lance holder.
(Slightly pull the terminal to check.)

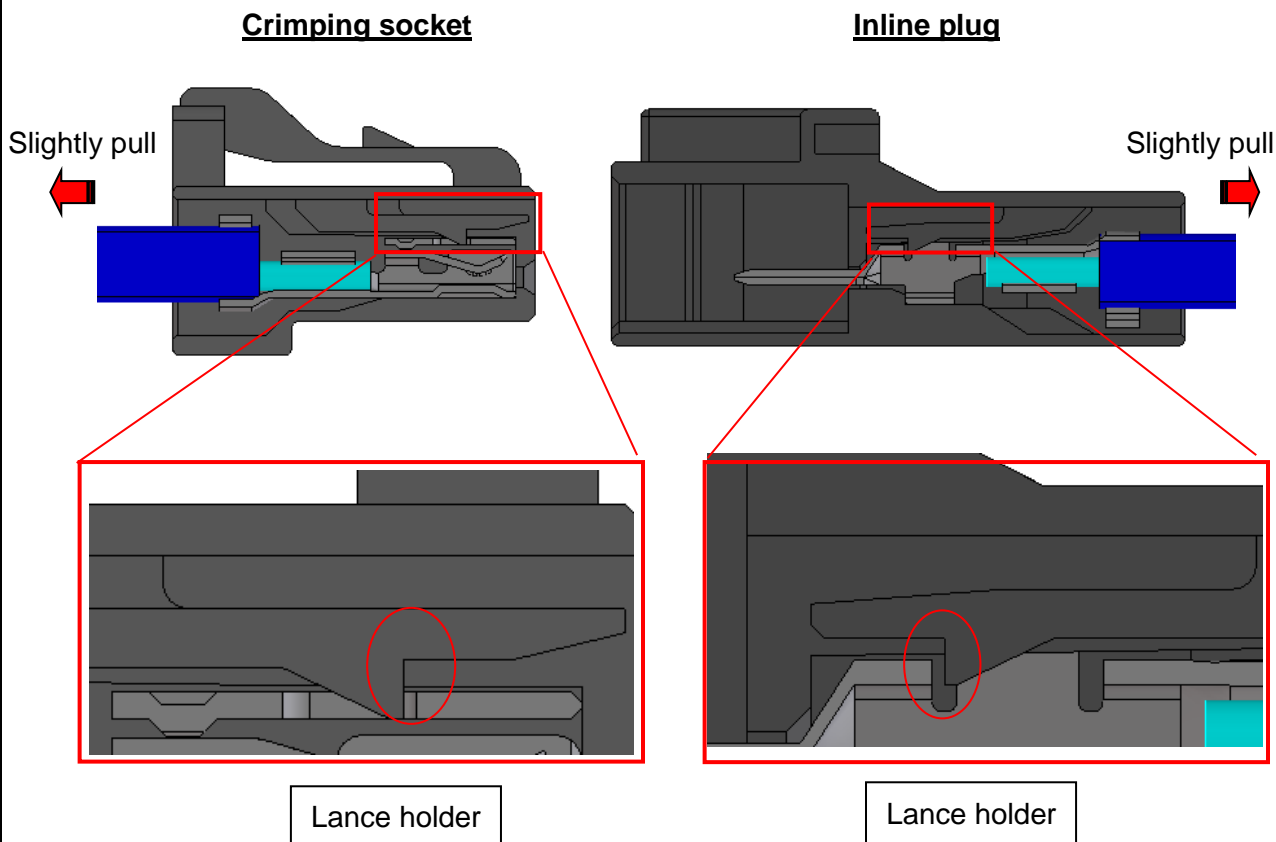

- Lance holding position

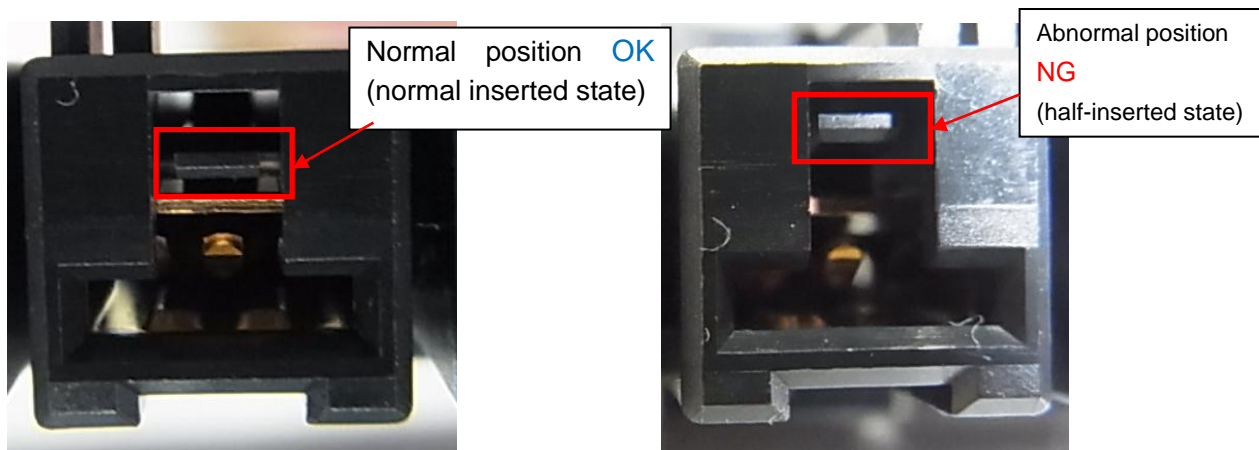

***Prohibited matters when checking terminal insertion**

When checking the terminal insertion state, please do not bend the cables as shown in the drawing below. Each of these cables has a thick core wire which is not very supple, and therefore, failure to observe this prohibition may apply stress to the connectors, which may cause the terminals to be disconnected.

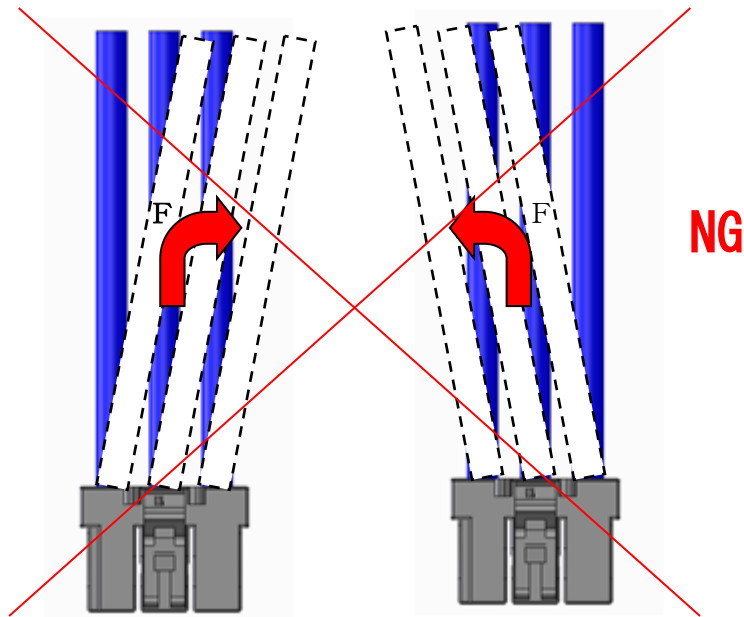

3. Removing contacts

1. Lift up molded lance by using precision screwdriver

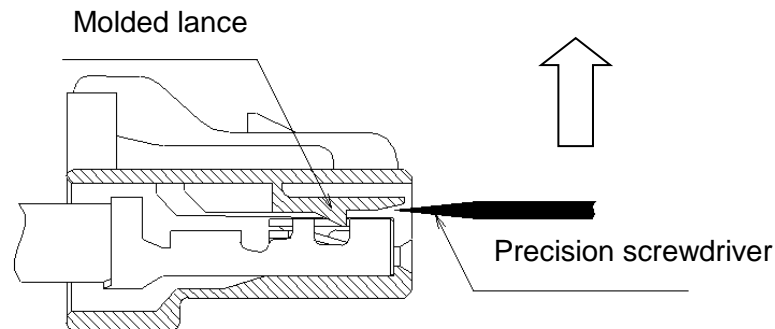

2. After lance is released from terminal, pull the cable and remove terminal from housing

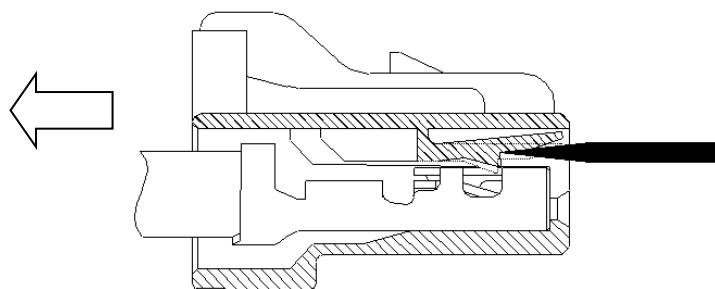

By doing repairs, the lance strength could be lower; therefore, do not reuse the crimp socket and the inline plug, simply replace them with new ones.

4. Precautions for handling

*Packing and storage

For packaging and storage of cable assemblies, please consider not to apply excessive force to the lock portion by its own weight.

Applying excessive force to the lock and the lock guard portion could cause damage.

Long term storage under hot and humid condition could cause deformation of the lock portion and result in mating failure.

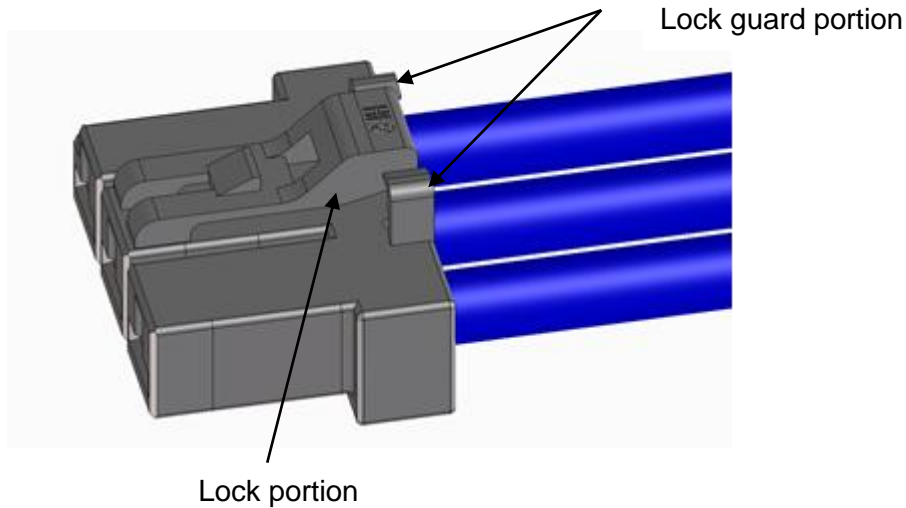

- Cable tying/Cabletyre cable stripping length

- Tying the cables near the socket may cause terminal disconnection, cable cut, unstable contact, etc. Thus, it is recommended to tie and strip the cables at a point at least 100 mm from the socket.

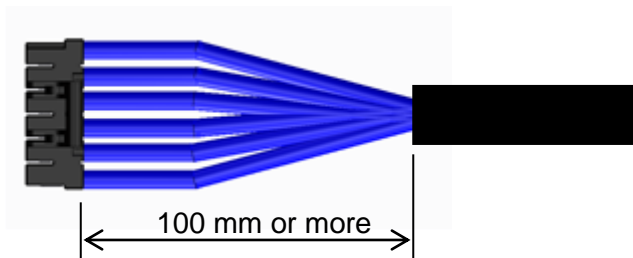

When using a multipole terminal, be aware that the strip length for the outside cables should be longer to provide it with a flexion portion, as well as to not apply any load such as excessive torsion.

