

Jul.1.2024 Copyright 2024 HIROSE ELECTRIC CO., LTD. All Rights Reserved.
 In case of consideration for using Automotive equipment / device which demand high reliability, kindly contact our sales window correspondents.

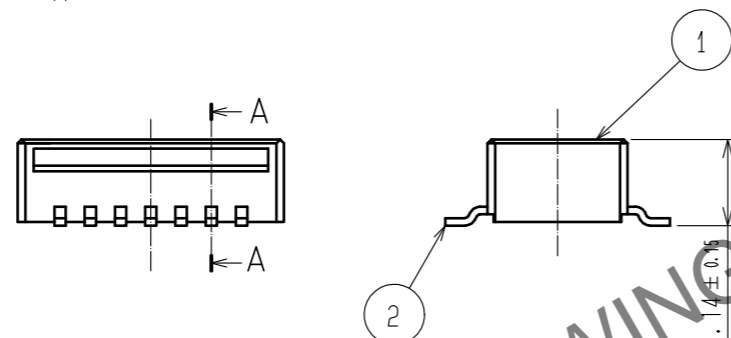

RECOMMENDED PATTERN

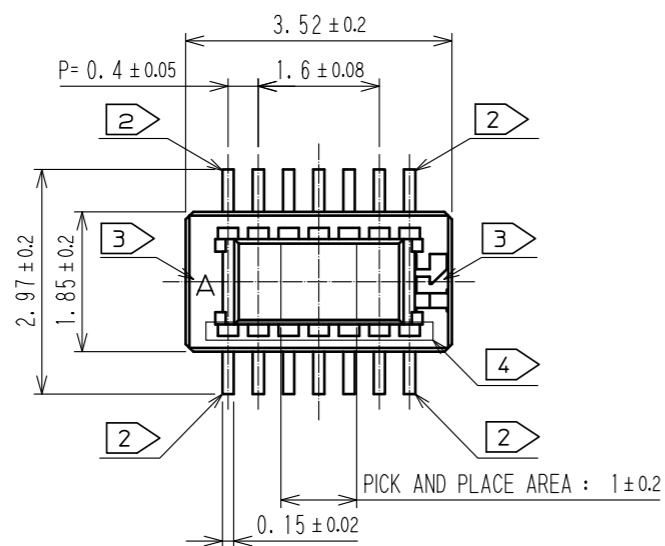
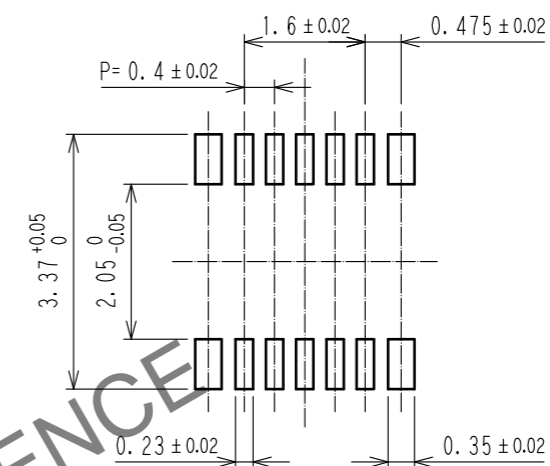

RECOMMENDED METAL MASK THICKNESS: 120 μm
 RECOMMENDED METAL MASK OPENING RATIO: 80% FOR LEAD PAD

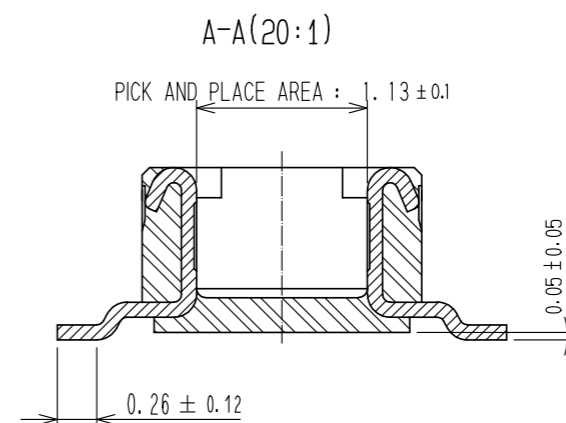

- NOTES
1. ALL LEADS CO-PLANARITY SHALL BE USED 0.1MAX.
 2. EACH ONE CONTACT AT 4 CORNERS SHALL BE USED AS METAL HOLD DOWN.
 3. HRS MARK AND CAV NO. ARE INDICATED IN APPROX. POSITION SHOWN.
 4. THERE IS A POSSIBILITY THAT THE RESIN WILL BE EXPOSED AT THIS AREA. BUT THIS WILL NOT AFFECT THE CONTACT RELIABILITY.

NO.	MATERIAL	FINISH . REMARKS	NO.	MATERIAL	FINISH . REMARKS
2	COPPER ALLOY	CONTACT AREA: GOLD 0.05 μm MIN	6	PS	CLEAR, REINFORCEMENT COLLAR
		SMT LEAD: GOLD 0.05 μm MIN	5	PS	BLACK
		UNDERPLATING: NICKEL 1 μm MIN	4	POLYESTER	CLEAR, COVER TAPE
1	LCP	BLACK, UL94V-0	3	PS	CLEAR, EMBOSSED CARRIER TAPE

UNITS	SCALE	COUNT	DESCRIPTION OF REVISIONS	DESIGNED	CHECKED	DATE
mm	10 : 1	△				

HRS HIROSE ELECTRIC CO., LTD.	APPROVED : WR. FUKUCHI	20210303	DRAWING NO.	EDC-386793-58-00
	CHECED : TS. MIYAZAKI	20210303	PART NO.	DF40TC-10DP-0.4V(58)
	DESIGNED : YK. SATAKE	20210303	CODE NO.	CL0684-4269-0-58
	DRAWN : YK. SATAKE	20210303		

Jul.1.2024 Copyright 2024 HIROSE ELECTRIC CO., LTD. All Rights Reserved.
 In case of consideration for using Automotive equipment / device which demand high reliability, kindly contact our sales window correspondents.

ENBOSSED CARRIER TAPE PACKAGING (5:1)

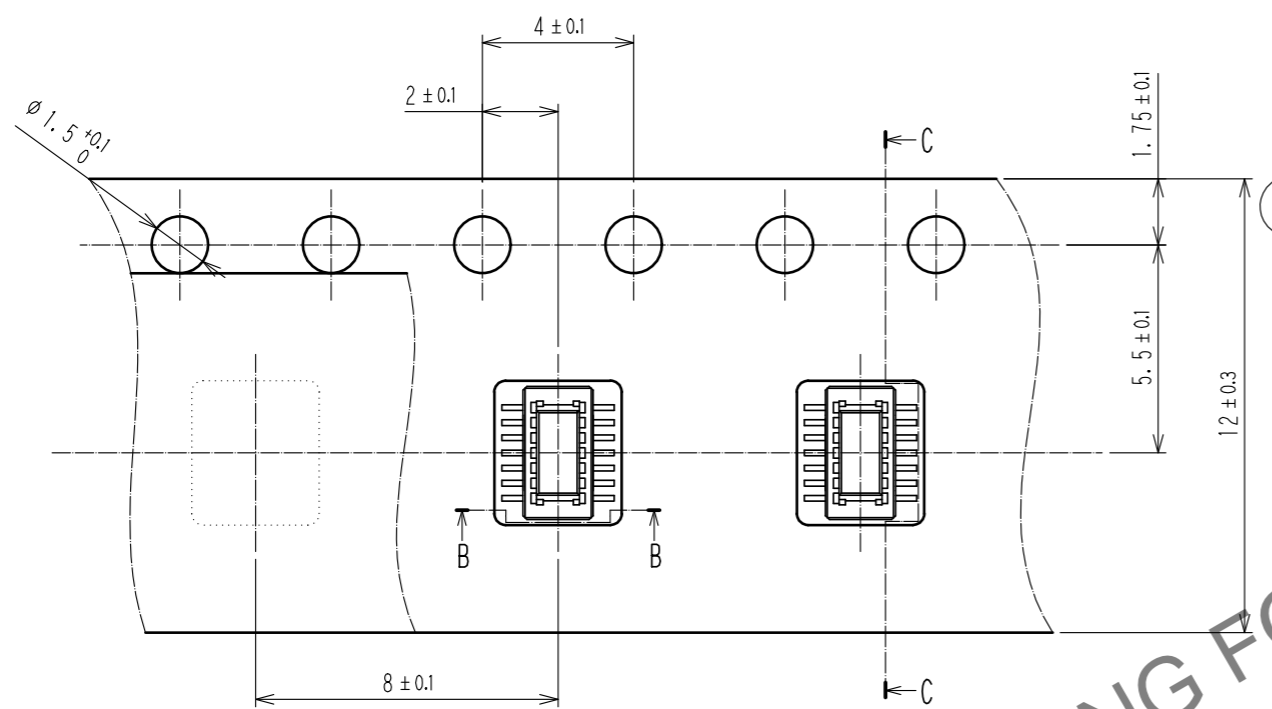

DIRECTION OF UNREELING

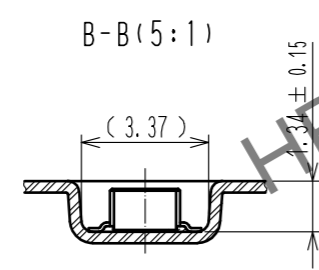

STYLE AND DIMENSIONS OF REEL (FREE)

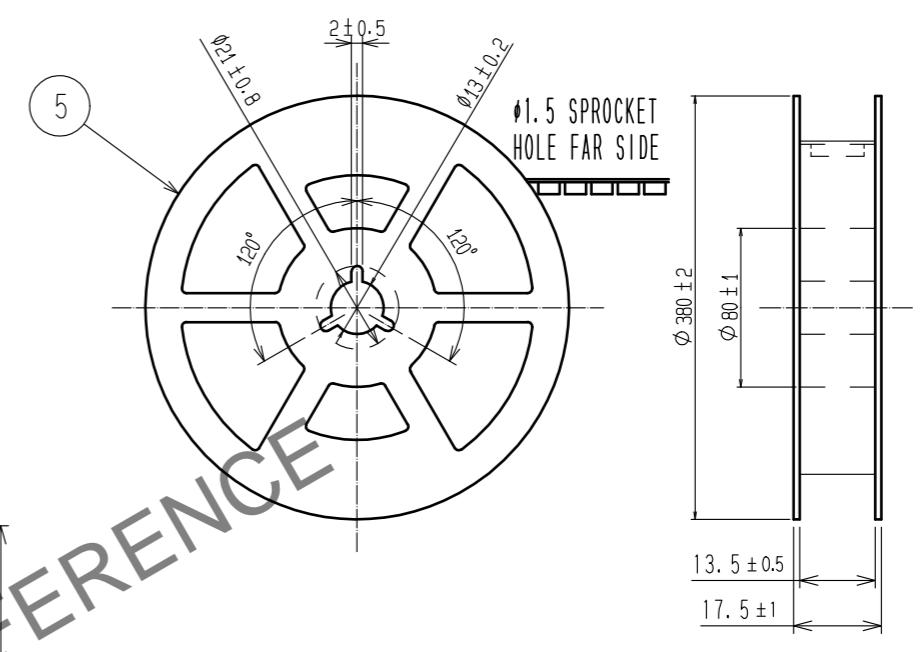

C-C (5:1)

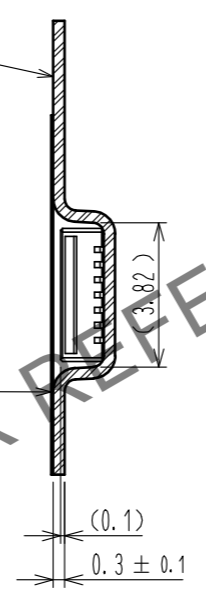

- NOTES
- 5. PER REEL 1000 CONNECTORS.
 - 6. THE DIMENSIONS IN PARENTHESES ARE FOR REFERENCE.
 - 7. REFER TO JIS C 0806 (PACKING OF COMPONENTS FOR AUTOMATIC HANDLING)
 - 8. AFTER PACKAGING, ROLL 2 METERS OF THE REINFORCEMENT COLLAR TO OUTER CIRCUMFERENCE OF TAPE AND REEL POCKET, AND TAPE DOWN AT THE END THE COLLAR.

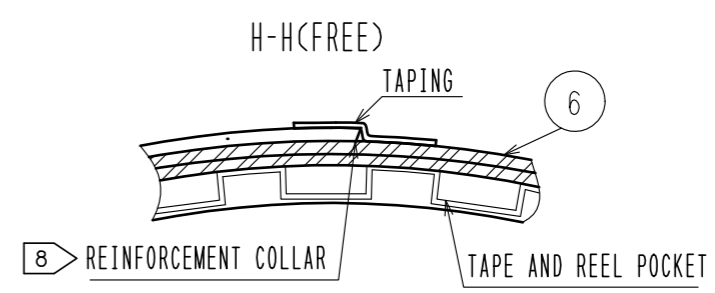
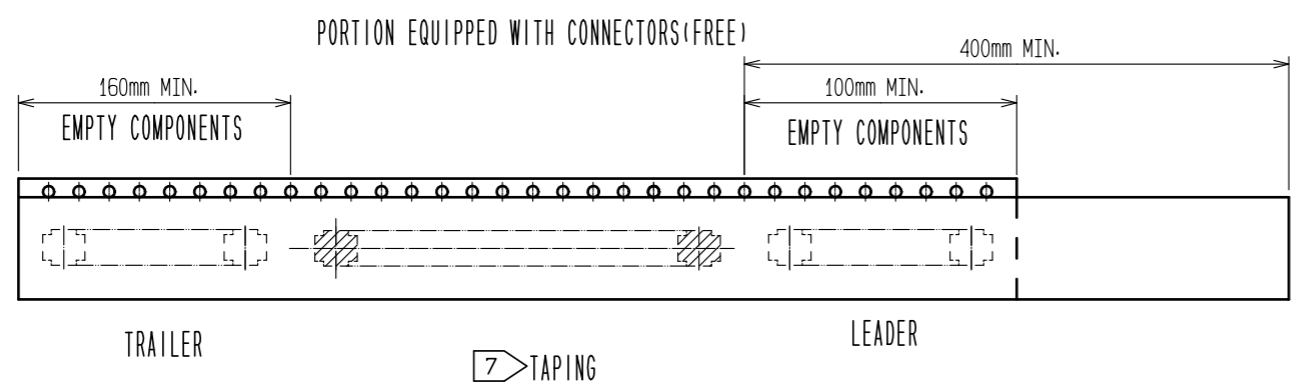

HRS	DRAWING NO.	EDC-386793-58-00
	PART NO.	DF40TC-10DP-0.4V(58)
	CODE NO.	CL0684-4269-0-58
		2/2