

Apr.1.2025 Copyright 2025 HIROSE ELECTRIC CO., LTD. All Rights Reserved.
In case of consideration for using Automotive equipment / device which demand high reliability, kindly contact our sales window correspondents.

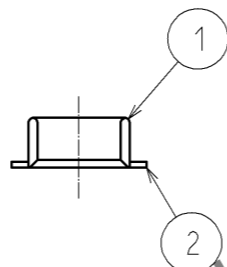

- NOTE 1 . ALL LEAD CO-PLANARITY SHALL BE 0.08mm MAX
- 2 . CONTACT PLATING SPECIFICATIONS
 CONTACT AREA : GOLD 0.05 μ m MIN
 SMT LEAD : GOLD 0.05 μ m MIN
 UNDER PLATING : NICKEL 1 μ m MIN
 (SURFACE : SEALING)
- 3 . EACH CONTACTS AT 4 CORNERS ARE PROVIDED FOR METAL FITTINGS.
- 4 . HRS MARK AND CAV No. ARE INDICATED IN APPROX POSITION SHOWN.
- 5 . A PART OF THE WALL COULD BE NOTCHED.

A-A (50:1)

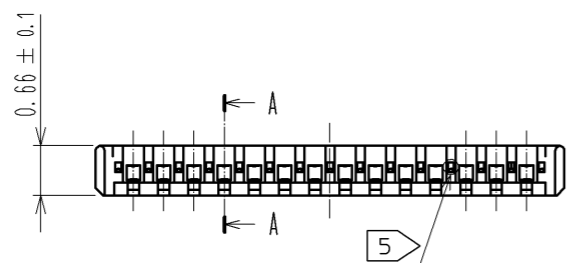
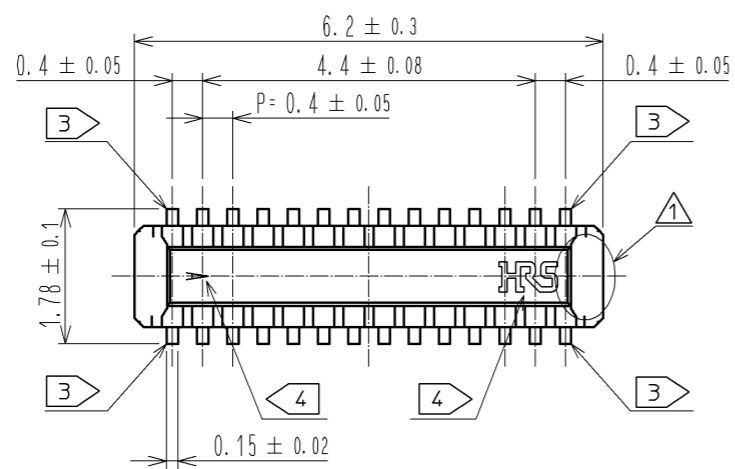
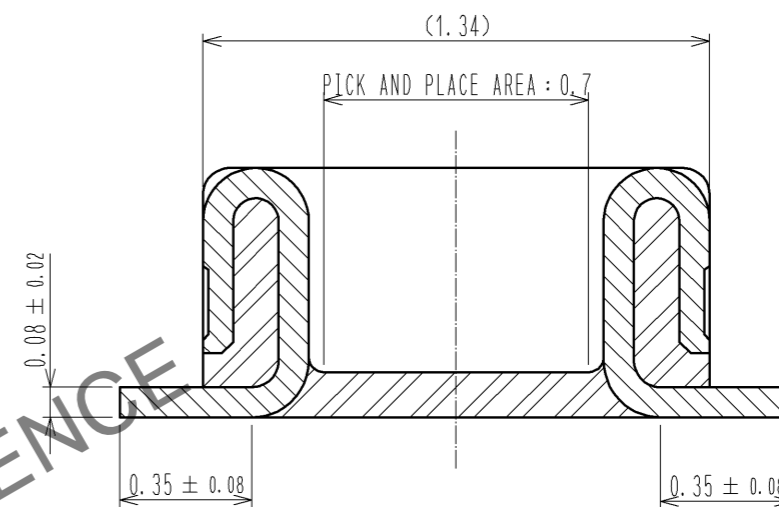

ENGAGEMENT FIGURE (50:1) \triangle

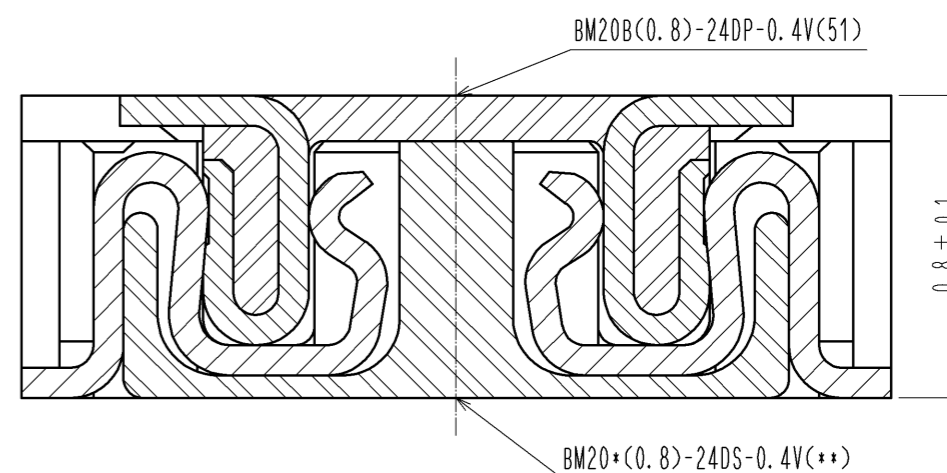

3	PS	CLEAR (EMBOSSED CARRIER TAPE)	6	PS	CLEAR (REINFORCEMENT COLLAR)		
2	PHOSPHOR BRONZE	2	5	PS	BLACK (PLASTIC REEL)		
1	LCP	UL94 V-0, BLACK	4	POLYESTER	CLEAR (COVER TAPE)		
NO.	MATERIAL	FINISH, REMARKS	NO.	MATERIAL	FINISH, REMARKS		
UNITS mm		SCALE 10:1	COUNT 4	DESCRIPTION OF REVISIONS DIS-H-006322	DESIGNED YK. SATAKE	CHECKED TS. MIYAZAKI	DATE 11.11.09
HRS HIROSE ELECTRIC CO., LTD.		APPROVED : KH. IKEDA 11.08.01	DRAWING NO. EDC3-332309-01				
		CHECKED : TS. MIYAZAKI 11.08.01	PART NO. BM20B(0.8)-24DP-0.4V(51)				
		DESIGNED : YK. SATAKE 11.07.28	CODE NO. CL684-9003-0-51				
		DRAWN : YK. SATAKE 11.07.28			\triangle 1/3		

Apr.1.2025 Copyright 2025 HIROSE ELECTRIC CO., LTD. All Rights Reserved.
 In case of consideration for using Automotive equipment / device which demand high reliability, kindly contact our sales window correspondents.

◆ RECOMMENDED PCB LAYOUT

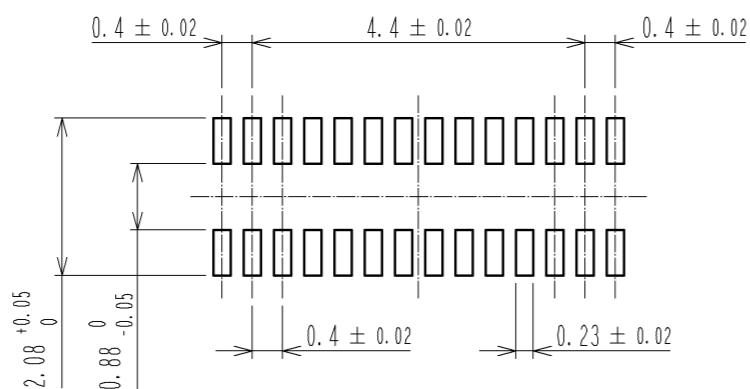

◆ RECOMMENDED METAL MASK DIMENSIONS \triangle

METAL MASK THICKNESS : $100 \mu\text{m}$

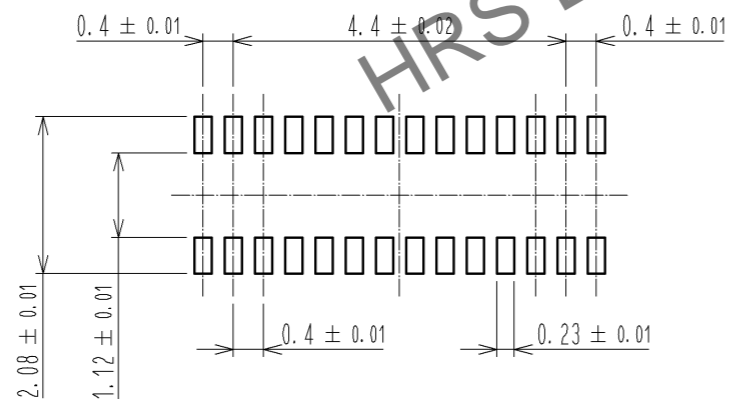

6 RECOMMENDED REFLOW TEMPERATURE PROFILE USING LEAD-FREE SOLDER PASTE.

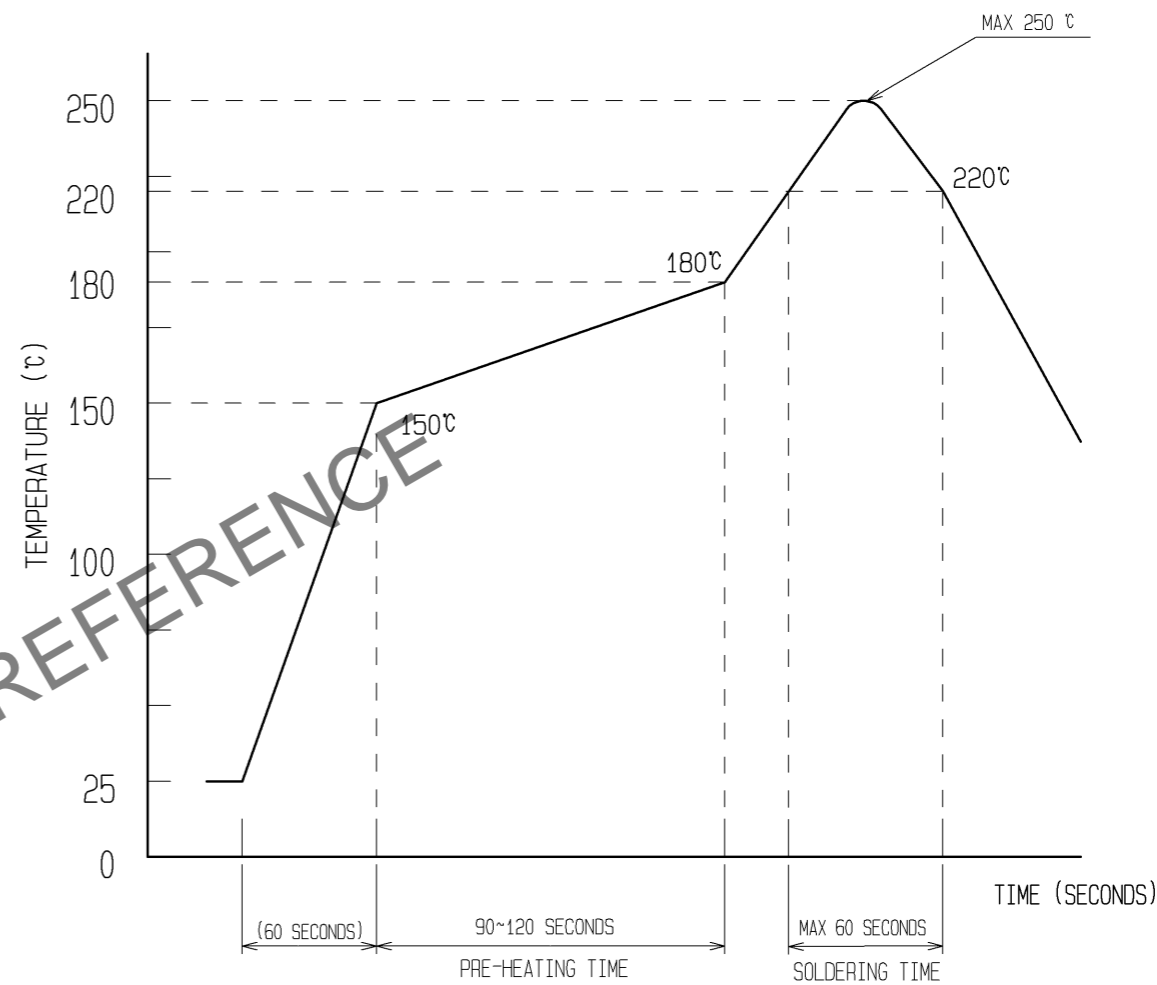

REFLOW METHOD: IR REFLOW
 NUMBER OF REFLOW CYCLES: 2 CYCLES MAX.
 1) REFLOW TIME
 DURATION ABOVE 220°C: 60 SEC MAX.
 (PEAK TEMPERATURE: 250°C MAX)
 2) PRE-HEAT TIME
 PRE-HEAT TEMPERATURE(MIN): 150°C
 PRE-HEAT TEMPERATURE(MAX): 180°C
 PRE-HEAT TIME: 90-120 SEC.

6 THIS TEMPERATURE PROFILE IS PER THE CONDITIONS SHOWN ABOVE. ADDITIONAL FACTORS, SUCH AS SOLDER PASTE TYPE, PCB SIZE AND OTHER MOUNTED COMPONENTS COULD AFFECT THE PROFILE. THEREFORE, A THOROUGH EVALUATION OF MOUNTING COONDITION IS REQUIRED PRIOR TO PRODUCTION. TEPERATURE IS MEASURED AT CONTACT LEAD.

HRS	DRAWING NO.	EDC3-332309-01
	PART NO.	BM20B(0.8)-24DP-0.4V(51)
	CODE NO.	CL684-9003-0-51 \triangle 2/3

Apr.1.2025 Copyright 2025 HIROSE ELECTRIC CO., LTD. All Rights Reserved.
 In case of consideration for using Automotive equipment / device which demand high reliability, kindly contact our sales window correspondents.

EMBOSED CARRIER TAPE PACKAGING (5:1)

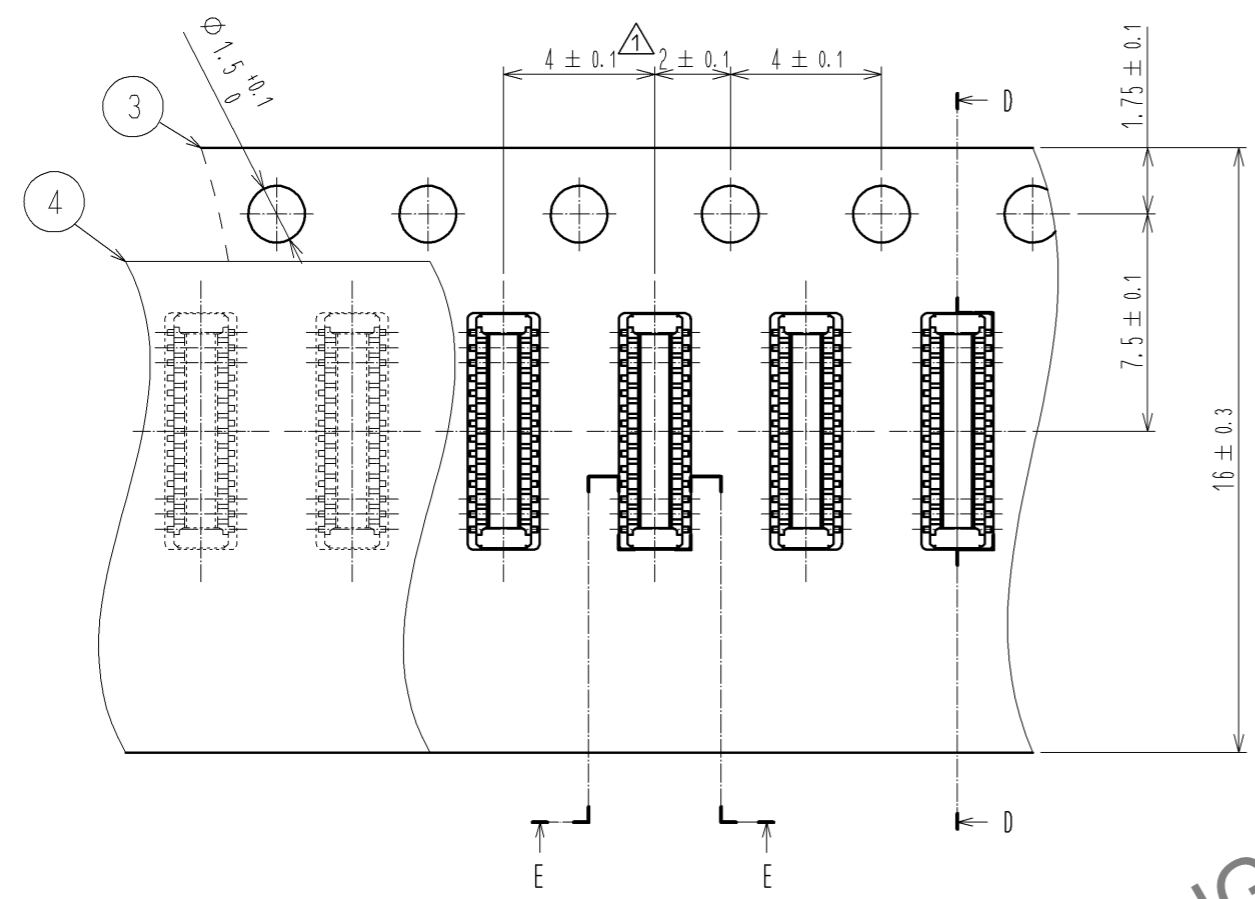

DIRECTION OF UNREELING

E-E (5:1)

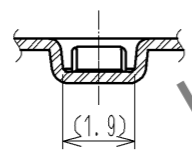

D-D (5:1)

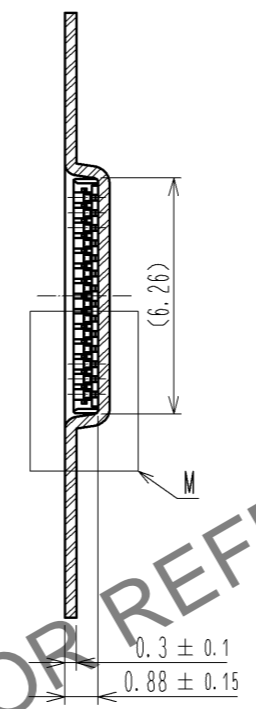

STYLE AND DIMENTION OF REEL (FREE)

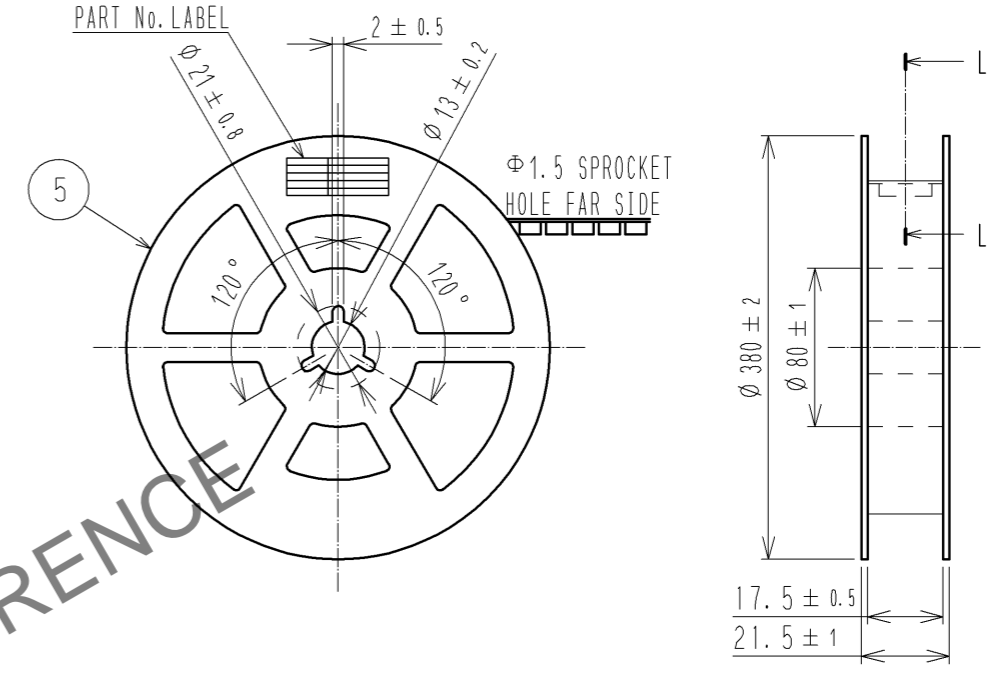

L-L (FREE)

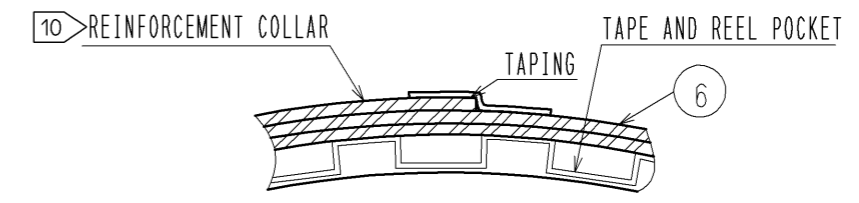

DETAIL OF PART No. LABEL

製造年月日	** ** *	DATE OF MANUFACTURED
製品コード	CL0684-9003-0-(51)	CODE No.
製品名	BM20B(0.8)-24DP-0.4V(51)	PART No.
数量	8,000	QUANTITY
納入者	ヒロセ電機(株)	SUPPLIER

- 7. PER REEL 8000 CONNECTORS.
- 8. THE DIMENTION IN PARENTHESSES ARE FOR REFERENCE.
- 9. REFER TO JIS C 0806(PACKAGING OF COMPONENTS FOR AUTOMATIC HANDLING)
- 10. AFTER PACKAGING, ROLL 2 METERS OF THE REINFORCEMENT COLLAR TO OUTER CIRCUMFERENCE OF TAPE AND REEL POCKET. AND TAPE DOWN AT THE END THE COLLAR.

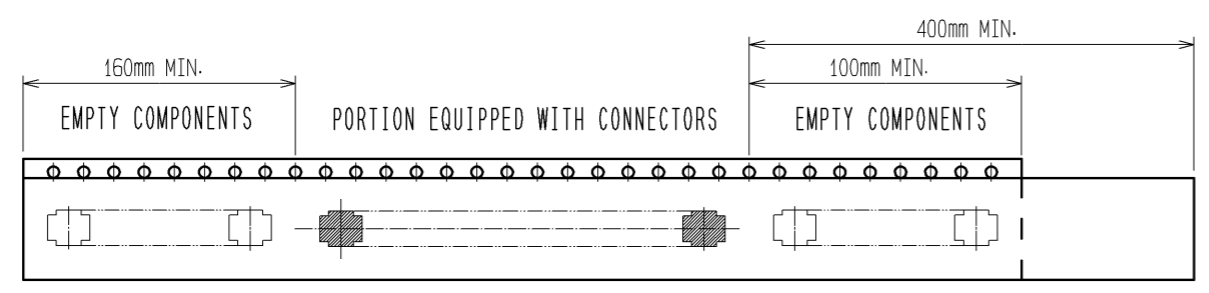

9 TAPING(FREE)

M (10:1)

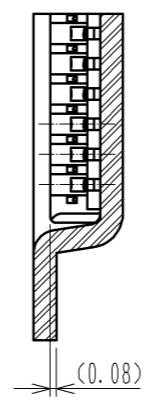

HRS	DRAWING NO.	EDC3-332309-01
	PART NO.	BM20B(0.8)-24DP-0.4V(51)
	CODE NO.	CL684-9003-0-51
		$\triangle 1$ 3/3