

May.1.2022 Copyright 2022 HIROSE ELECTRIC CO., LTD. All Rights Reserved.  
In case of consideration for using Automotive equipment / device which demand high reliability, kindly contact our sales window correspondents.

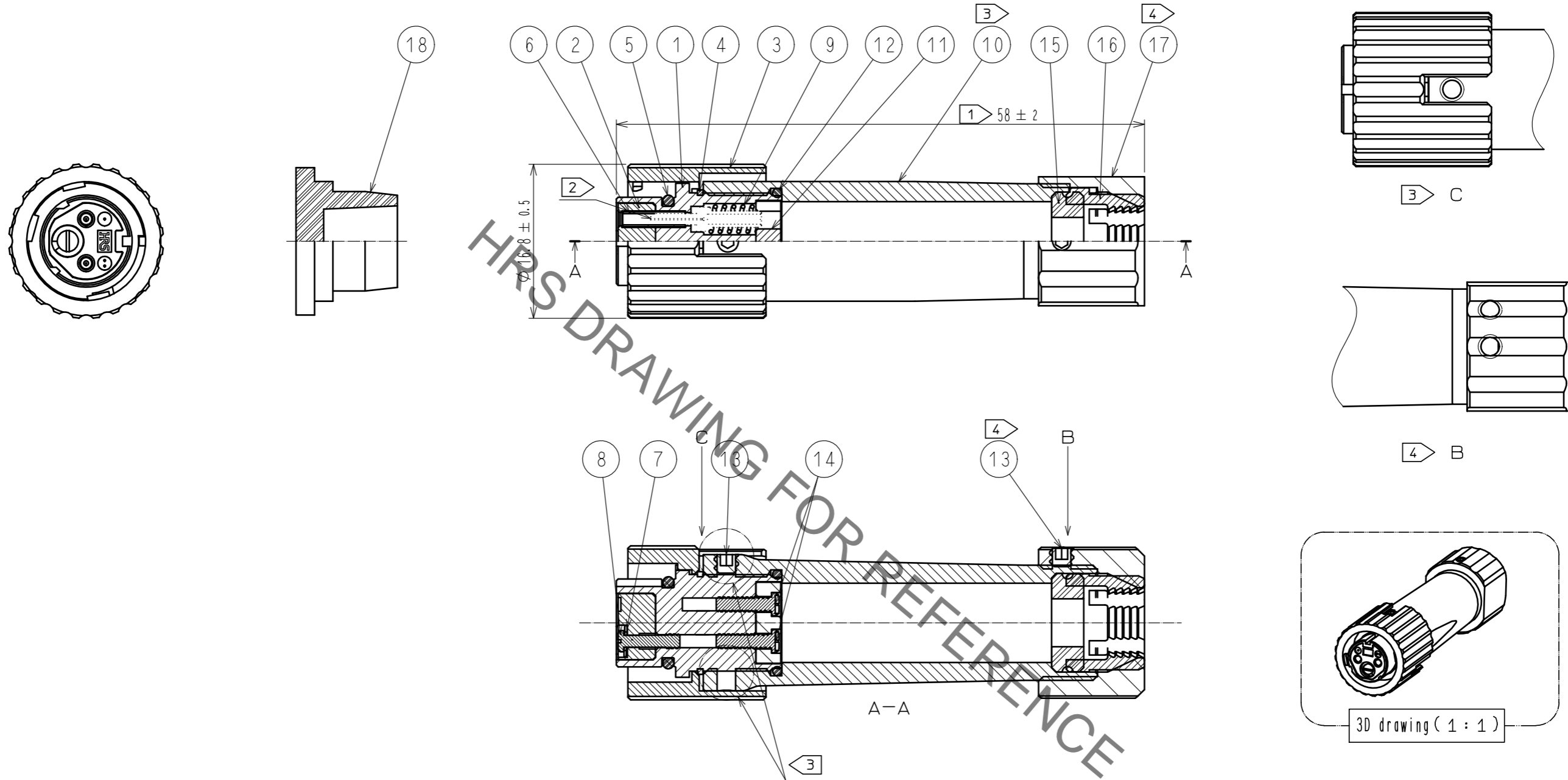

- NOTE
- ① These dimensions indicate the condition after cable assembly.
  - ② Ferrules are not included in this product. MU ferrules are separately available.
  - ③ Housing of part No. 10 has two holes for fixing with sleeve of part No. 1 by hexagon socket screw of part No. 13. Tighten the screw at either hole that is visible from a slit on the sleeve as shown in section C.
  - ④ Tightening ring of part No. 17 has two holes for fixing hexagon socket screw of part No. 13. Tighten the screw at visible either hole, or either hole if both holes are visible.
5. For cleaning of the ferrule end, loosen the screw of part No. 8 and pick up the pre-assembled P shell B of part No. 2 by pulling the screw of part No. 8. Then, remove the split sleeves by using separately available sleeve-remover and clean the ferrules.

9	PIANO WIRE	ZINC PLATING + BAKING PROCESSING	18	SYNTHETIC RUBBER (SIR)	COLOR:BLACK
8	STAINLESS STEEL	—————	17	ZINC DIE CASTING	CHROME PLATING (COLOR:BLACK)
7	STAINLESS STEEL	—————	16	PA RESIN	COLOR:WHITE
6	ZIRCONIA	—————	15	SYNTHETIC RUBBER (CR)	COLOR:BLACK
5	SYNTHETIC RUBBER (NBR)	COLOR:BLACK	14	STAINLESS STEEL	—————
4	STAINLESS STEEL	—————	13	STAINLESS STEEL	—————
3	ZINC DIE CASTING	CHROME PLATING (COLOR:BLACK)	12	CR RUBBER	COLOR:BLACK
2	ZINC DIE CASTING	CHROME PLATING (COLOR:BLACK)	11	ZINC DIE CASTING	NICKEL PLATING
1	ZINC DIE CASTING	CHROME PLATING (COLOR:BLACK)	10	ZINC DIE CASTING	CHROME PLATING (COLOR:BLACK)
NO.	MATERIAL	FINISH . REMARKS	NO.	MATERIAL	FINISH . REMARKS

UNITS	SCALE	COUNT	DESCRIPTION OF REVISIONS	DESIGNED	CHECKED	DATE
mm	2 : 1	△				
			APPROVED : MT. SHIBUTANI 18.02.02 CHECKED : FS. YOSHIDA 18.02.02 DESIGNED : TY. SATO 18.02.02 DRAWN : MK. INOUE 18.02.02	DRAWING NO. EDC-178352-31-00 PART NO. MF10B-WP6.5CH02-0200(31) CODE NO. CL709-1040-5-31		