

Sep.1.2024 Copyright 2024 HIROSE ELECTRIC CO., LTD. All Rights Reserved.
In case of consideration for using Automotive equipment / device which demand high reliability, kindly contact our sales window correspondents.

ELV, RoHS COMPLIANT

△ RECOMMENDED PCB PATTERN (FREE)

MATED CONNECTORS (FREE)

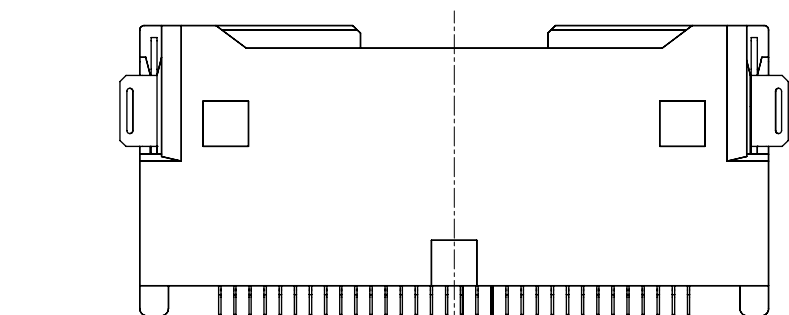
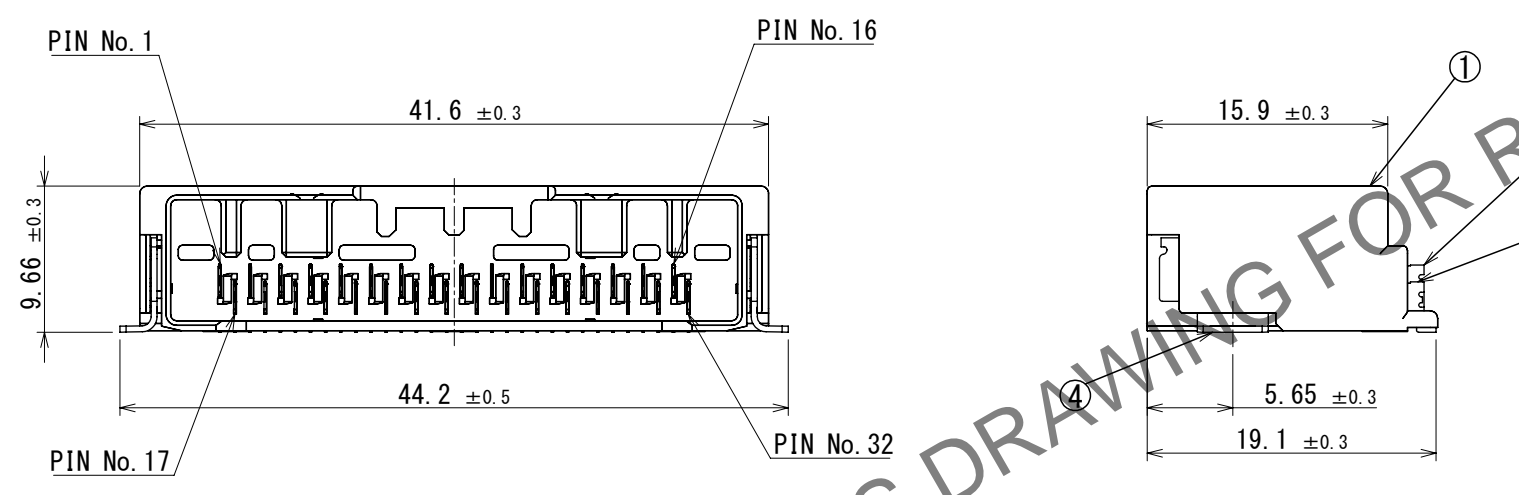
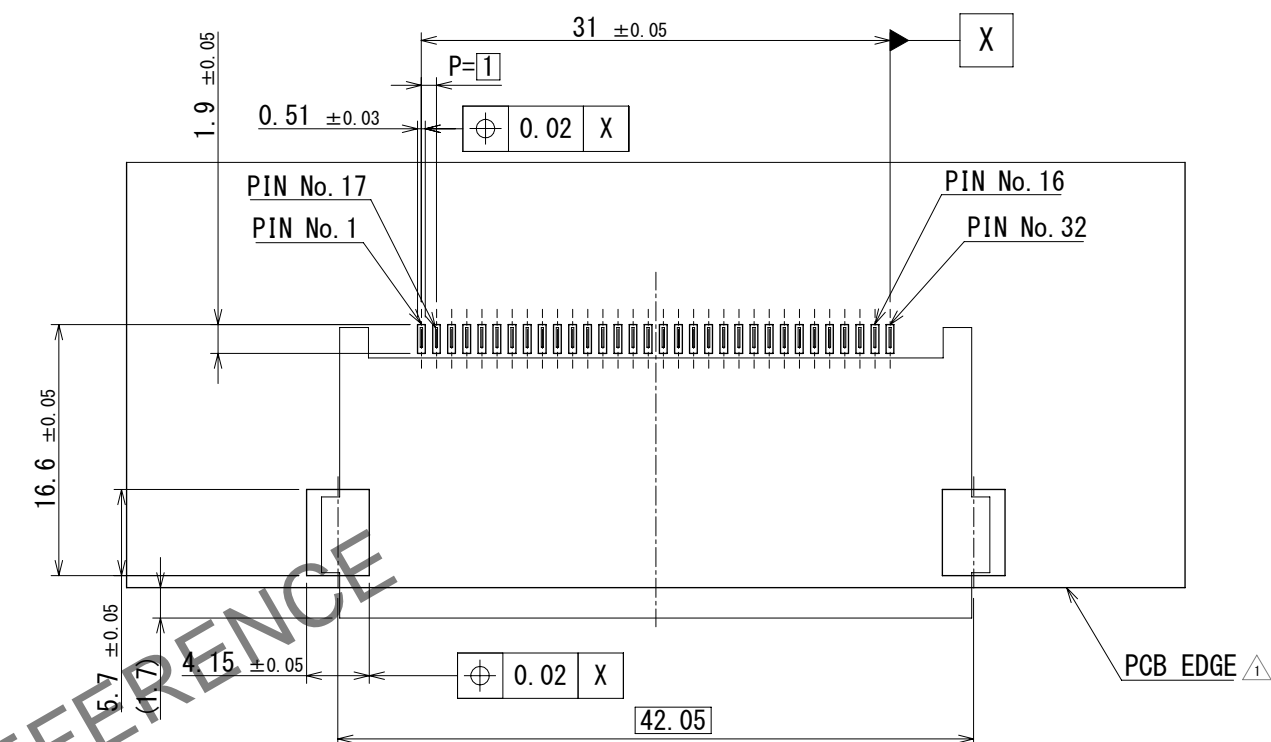
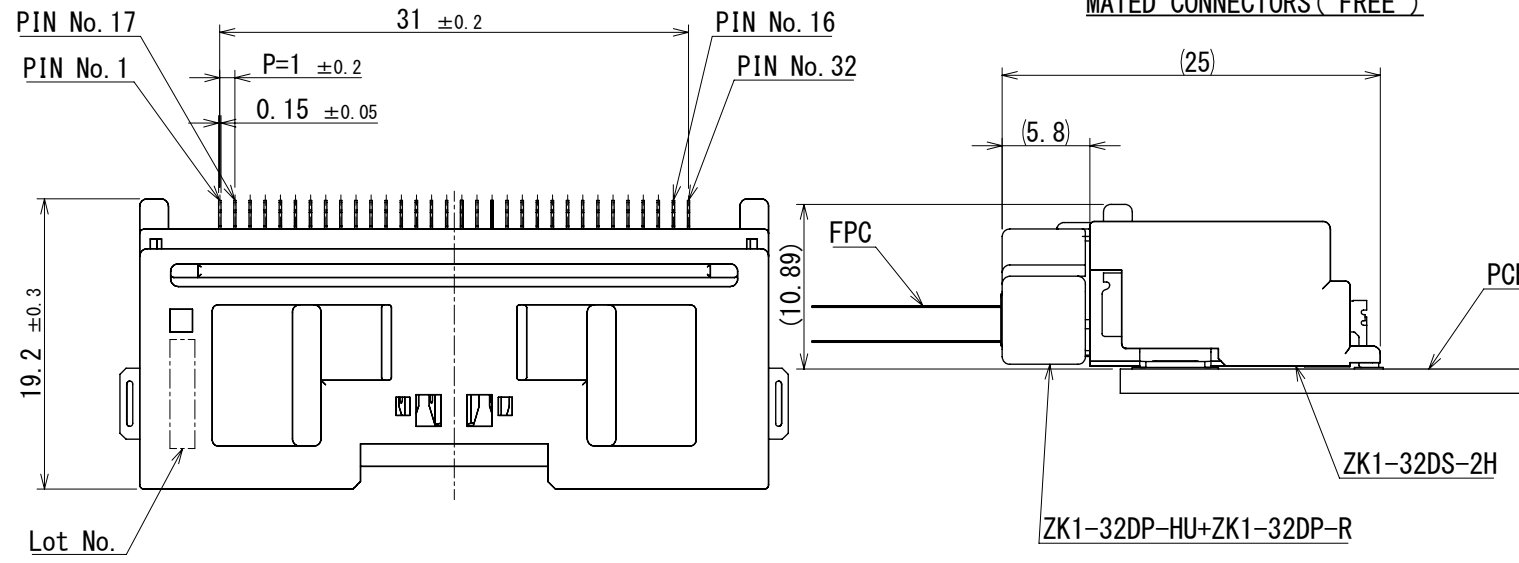

NOTE1. RECOMMENDED TEMPERATURE PROFILE FOR REFLOW
(REFER TO RIGHT FIG.)
USED REFLOW SYSTEM

NO. OF CYCLES : IR IN THE AIR OR NITROGEN
PEAK : 250°C
OVER 230°C : 20~40s
PREHEAT : 150~180°C
90~120s

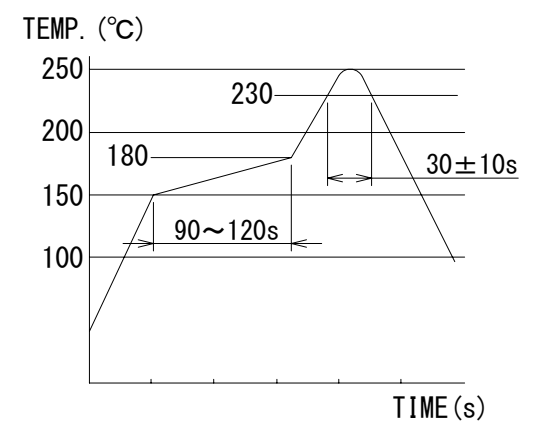

- 2. CO-PLANARITY SHALL BE 0.1mm MAX.
- 3. RECOMMENDED PCB THICKNESS IS 1.6mm.
- 4. RECOMMENDED SOLDER THICKNESS IS 0.15mm.
- △ 5. PLEASE REFER TO GUIDELINE ETAD-T1037-00 BEFORE USE.

4	BRASS	SURFACE : TIN PLATING 1 μm MIN UNDER : NICKEL PLATING 1 μm MIN			
3	COPPER ALLOY	CONTACT AREA : Au PLATING 0.1 μm MIN LEAD : Au PLATING 0.05 μm MIN UNDER : NICKEL PLATING 1 μm MIN	7	PS	
2	COPPER ALLOY		6	POLYESTER	
1	PA	BLACK	5	POLYSTYRENE	
NO.	MATERIAL	FINISH , REMARKS	NO.	MATERIAL	FINISH , REMARKS
UNITS mm		SCALE 2:1	COUNT 4	DESCRIPTION OF REVISIONS DIS-T-00021251	
DESIGNED INYONG KIM		CHECKED TY. MOGI		DATE 2024. 06. 23	
APPROVED : AH. EDASHIGE 2023. 10. 17		DRAWING NO. EDC-397751-00-00			
CHECKED : HH. TSUKUMO 2023. 10. 16		PART NO. ZK1-32DS-2H			
DESIGNED : TS. SHIMIZU 2023. 10. 16		CODE NO. CL0755-2100-0-00			
DRAWN : MA. TAGUCHI 2023. 10. 16					

Sep.1.2024 Copyright 2024 HIROSE ELECTRIC CO., LTD. All Rights Reserved.
In case of consideration for using Automotive equipment / device which demand high reliability, kindly contact our sales window correspondents.

PACKING STYLE (FREE)

REEL DIMENSION (FREE)

PACKING STYLE DRAWING

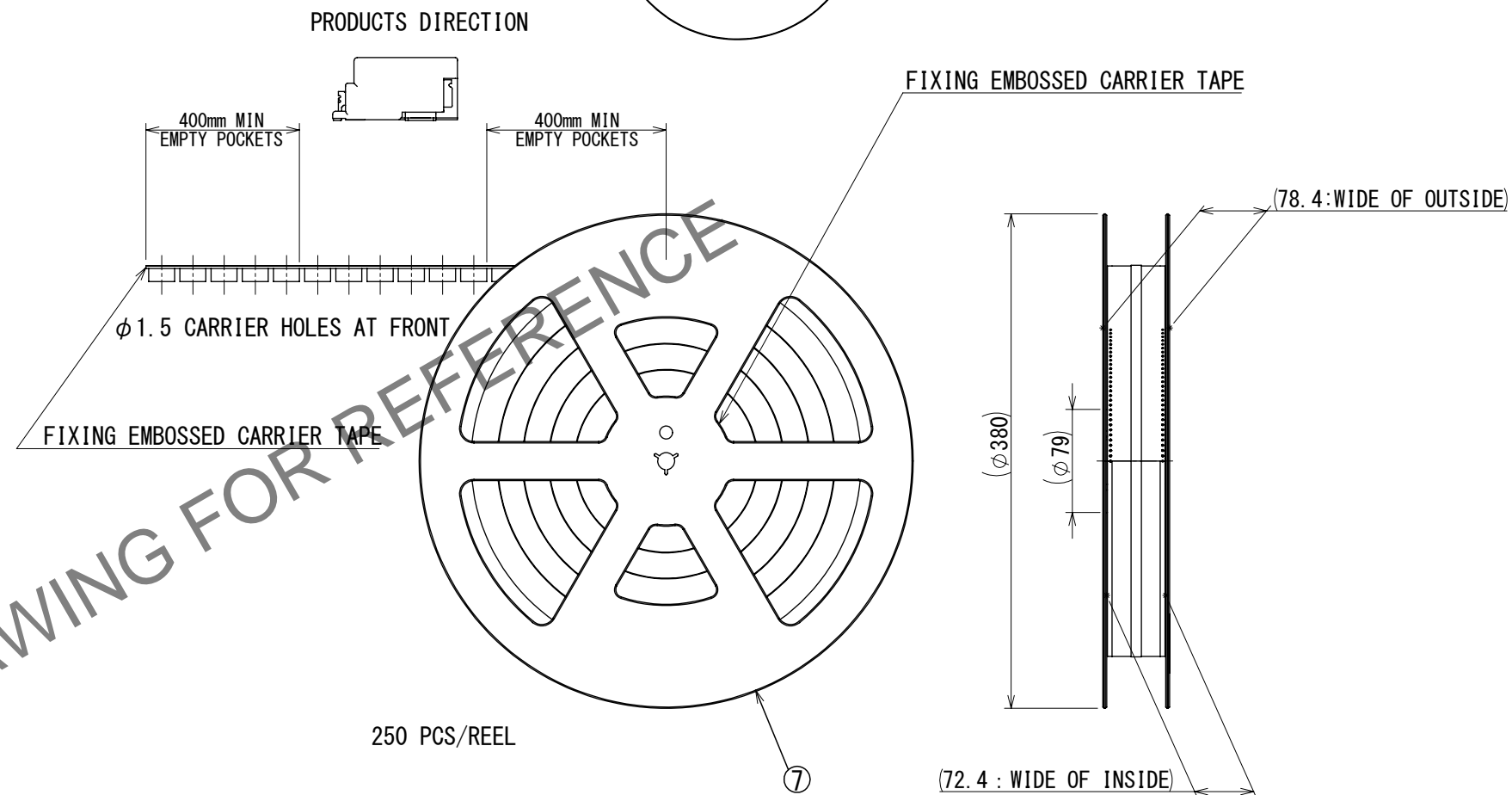
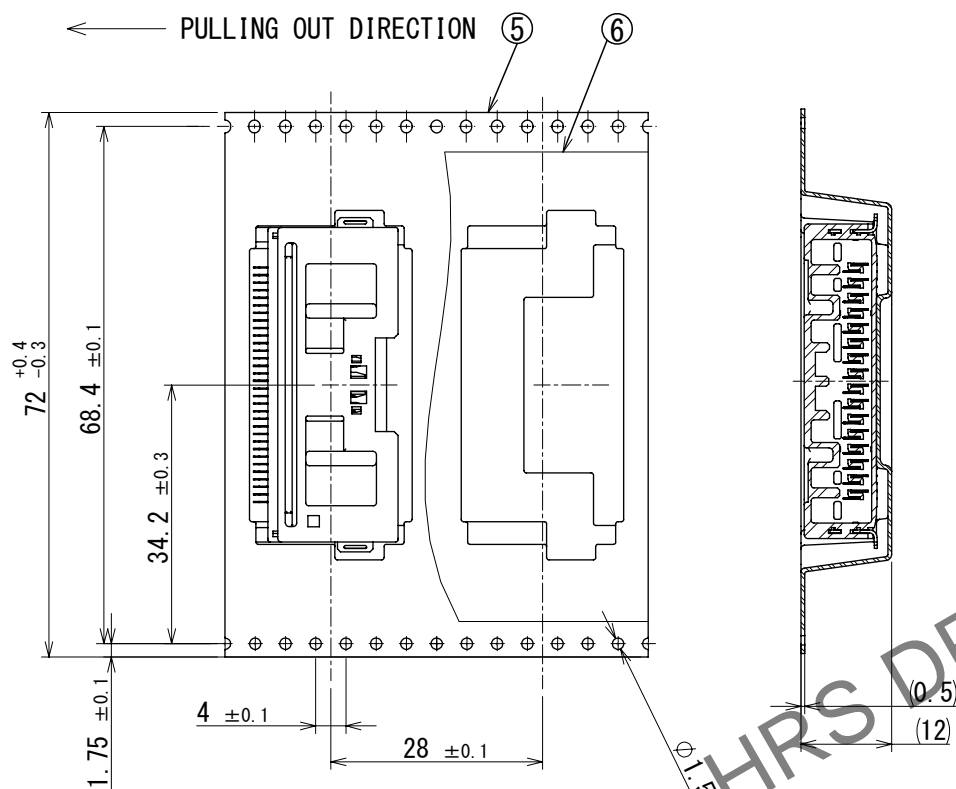

CARDBOARD DIMENSION

W= (405) (mm)
 D= (405) (mm)
 H= (80) (mm)

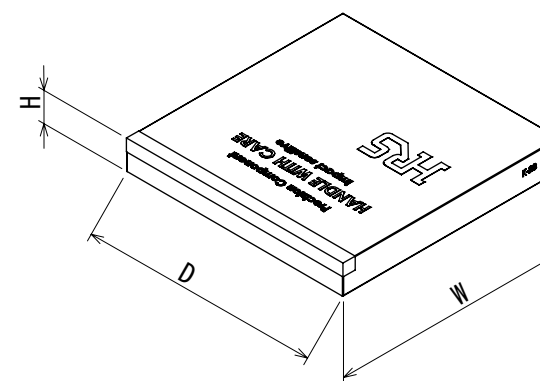

△ Frame change

HRS	DRAWING NO.	EDC-397751-00-00	2/2
	PART NO.	ZK1-32DS-2H	
	CODE NO.	CL0755-2100-0-00	
	NO.		