

Aug.1.2024 Copyright 2024 HIROSE ELECTRIC CO., LTD. All Rights Reserved.
In case of consideration for using Automotive equipment / device which demand high reliability, kindly contact our sales window correspondents.

ELV, RoHS COMPLIANT

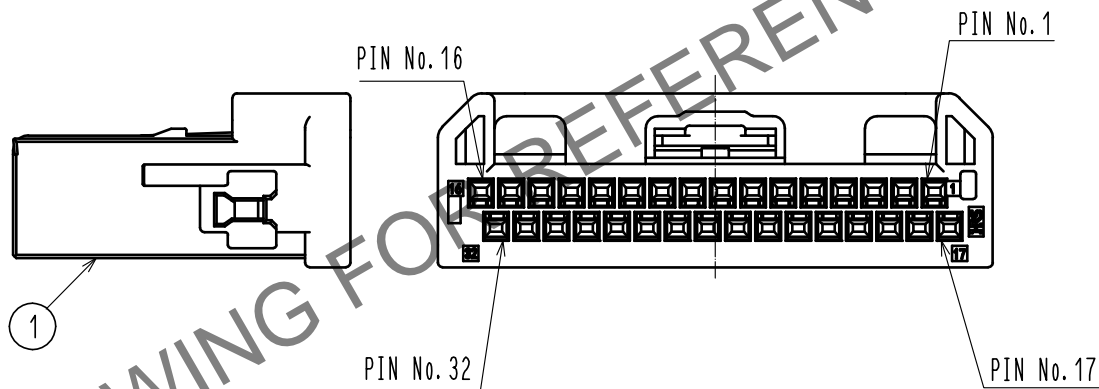
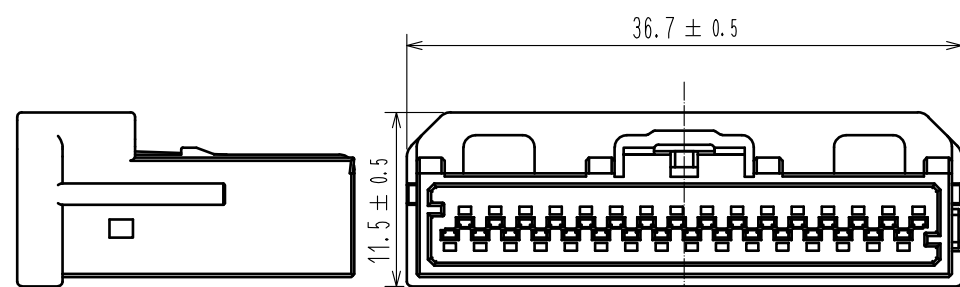
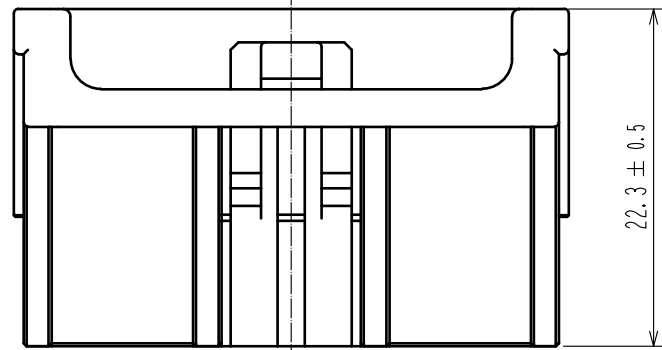

NOTE1. RETAINER ZH05-32DP-R (CL756-2220-0-00) SHOULD BE USED

1. PACKAGING SPECIFICATION

- (1) 100pcs parts are contained in a plastic bag.
- (2) 5 plastic bags are contained in a carton.
(Total 500 pcs in one carton)
- (3) Close the box and seal with packing tape.

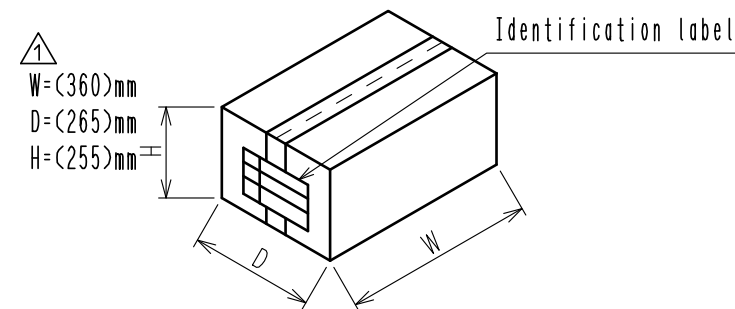

2. ASSEMBLY PROCESS

Note: Please refer to the Crimp Quality Standard for details on strip length.

① Strip the cable

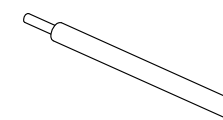

② Crimp wire in terminal

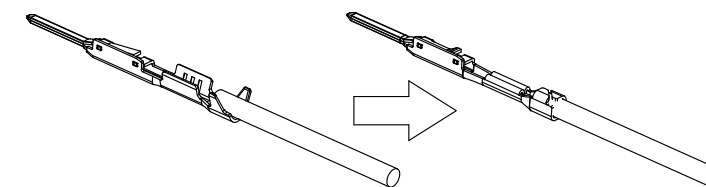

NOTE 1: Please use the Hirose crimp tool.
NOTE 2: Please refer to the Crimp Quality Standard to confirm terminal compatibility and check crimp condition.

Continued on the following page

1	PA	DARK GRAY UL94V-0	
NO.	MATERIAL	FINISH . REMARKS	NO. MATERIAL FINISH . REMARKS
UNITS mm		SCALE 2 : 1	COUNT 1
DESCRIPTION OF REVISIONS		DESIGNED	CHECKED
DIS-T-00018133		YANG CHUAN XING	MH. SHOUJI
DATE 20230518		DATE 20230518	
APPROVED : MH. SHOUJI 20230301		DRAWING NO. EDC-399092-00-00	
CHECKED : MH. SHOUJI 20230301		PART NO. ZH05-32DP-HU(B)	
DESIGNED : YANG CHUAN XING 20230301		CODE NO. CL0756-2219-0-00	
DRAWN : LIANGCHEN LI 20230301		1/4	

Aug.1.2024 Copyright 2024 HIROSE ELECTRIC CO., LTD. All Rights Reserved.
In case of consideration for using Automotive equipment / device which demand high reliability, kindly contact our sales window correspondents.

③ Insert contact and push until a click is heard.
※ Please take care to ensure that the terminal is inserted in the correct orientation.

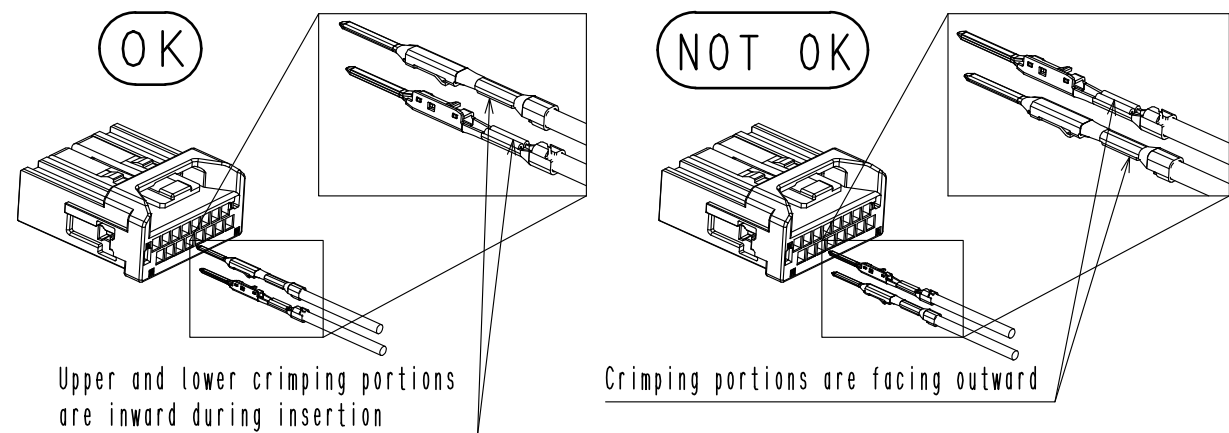

NOTE 1: Holding the cable, please insert straight into the housing.
Do not use more than 10N of force during this process.
NOTE 2: If the crimped terminal does not enter the housing smoothly the first time, remove it and then re-insert.
※ Please hold the cable as below picture and insert it with a force less than 10 N, or terminal will be deformed. Please use a new terminal in this case.

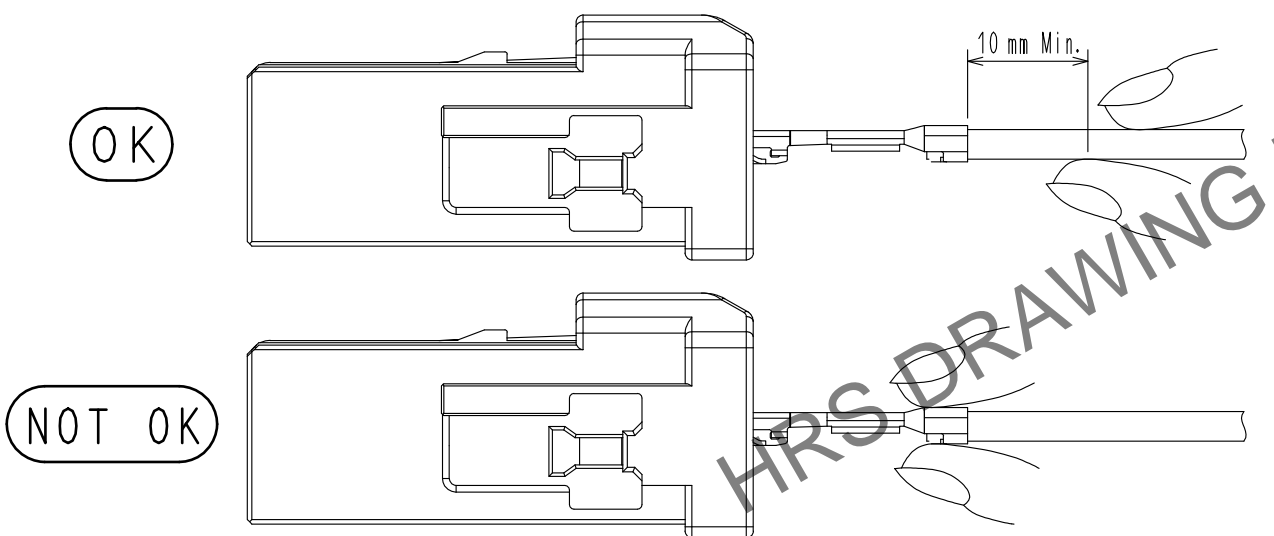

④ After insertion, confirm that the terminal has been inserted correctly by pulling the cable lightly, the pulling force must be less than 10N.

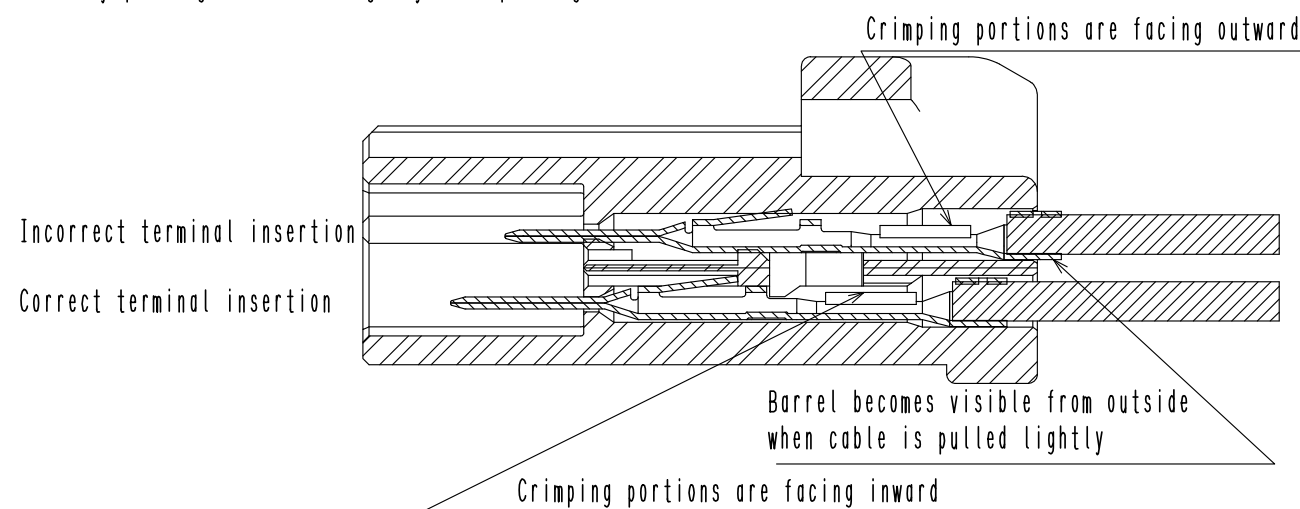

⑤ Press retainer into housing until it clicks in the direction of the arrow.

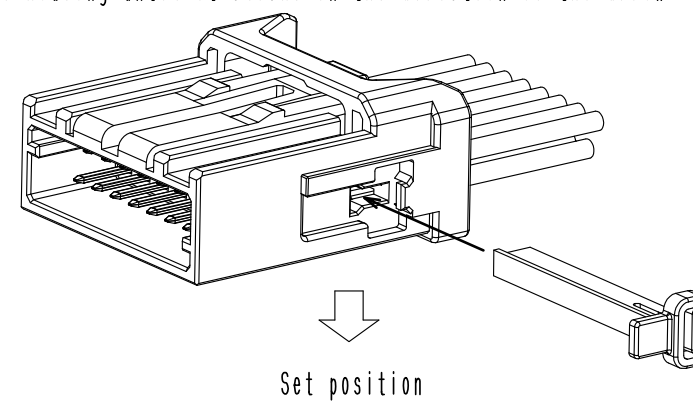

After setting the retainer, please inspect the housing head-on to confirm that the retainer is not protruding in any way.

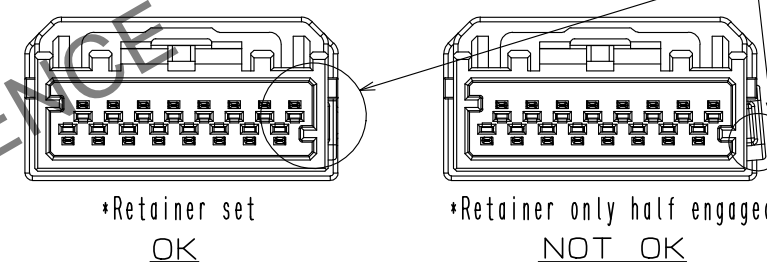

Confirm the retainer is visible.

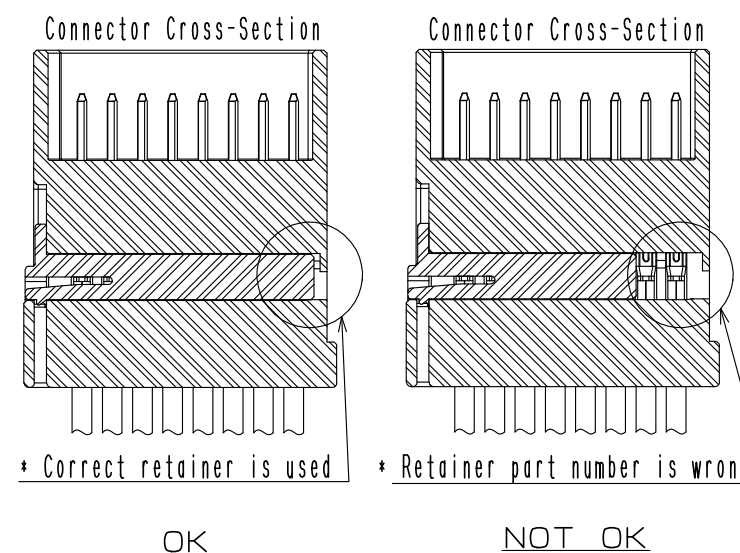
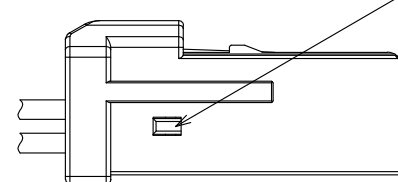

HRS	DRAWING NO.	EDC-399092-00-00
	PART NO.	ZH05-32DP-HU(B)
	CODE NO.	CL0756-2219-0-00
		2/4

3. REPAIR PROCESS

① Insert the special tool in direction ① and push down the lance, and remove the retainer from direction ②.
 Note: Please refer to the following section for details on the special tool.

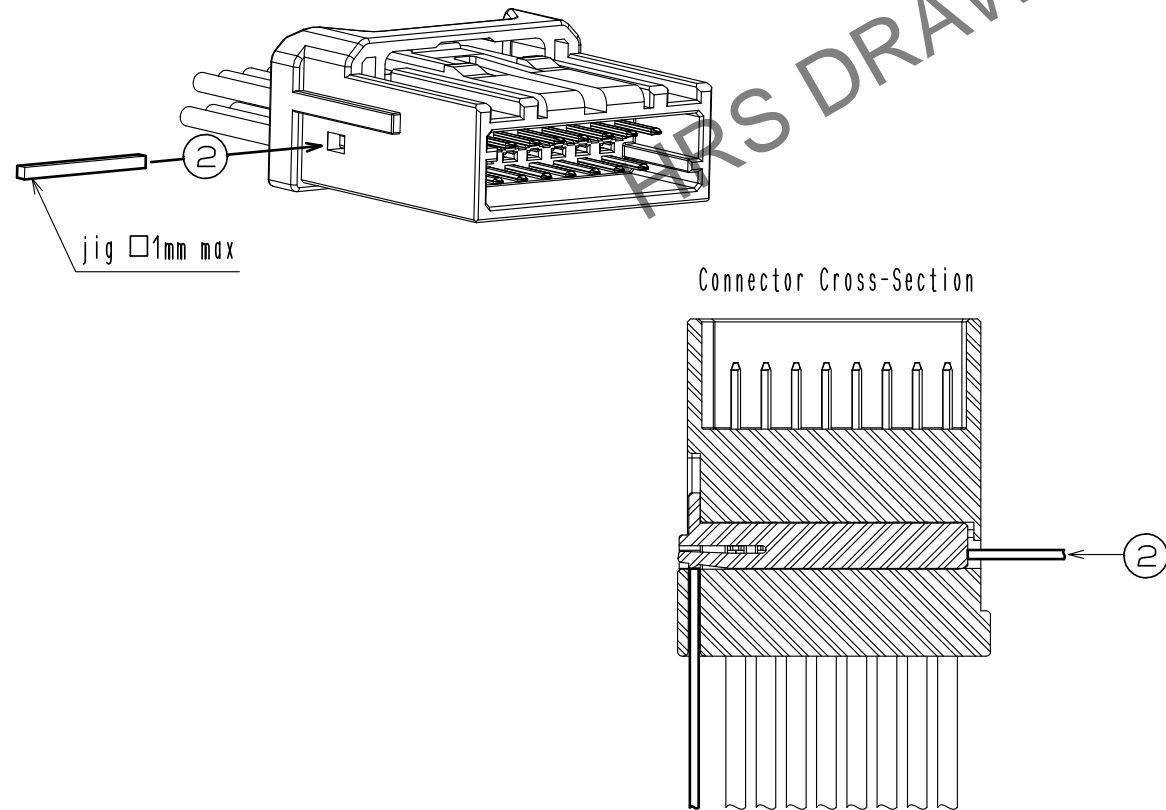
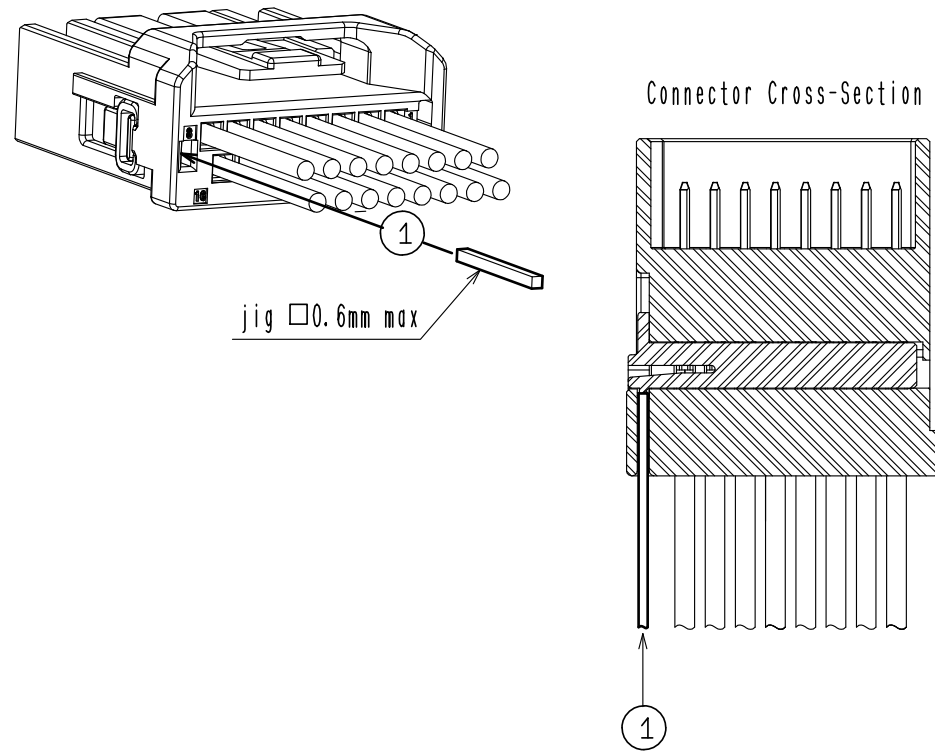

② Insert the special tool into the terminal cavity and push to the end with the tool flat side up as below picture. Maintain this position and pull the applicable cable carefully to remove the terminal.
 Note: Please refer to the following section for details on the special tool.

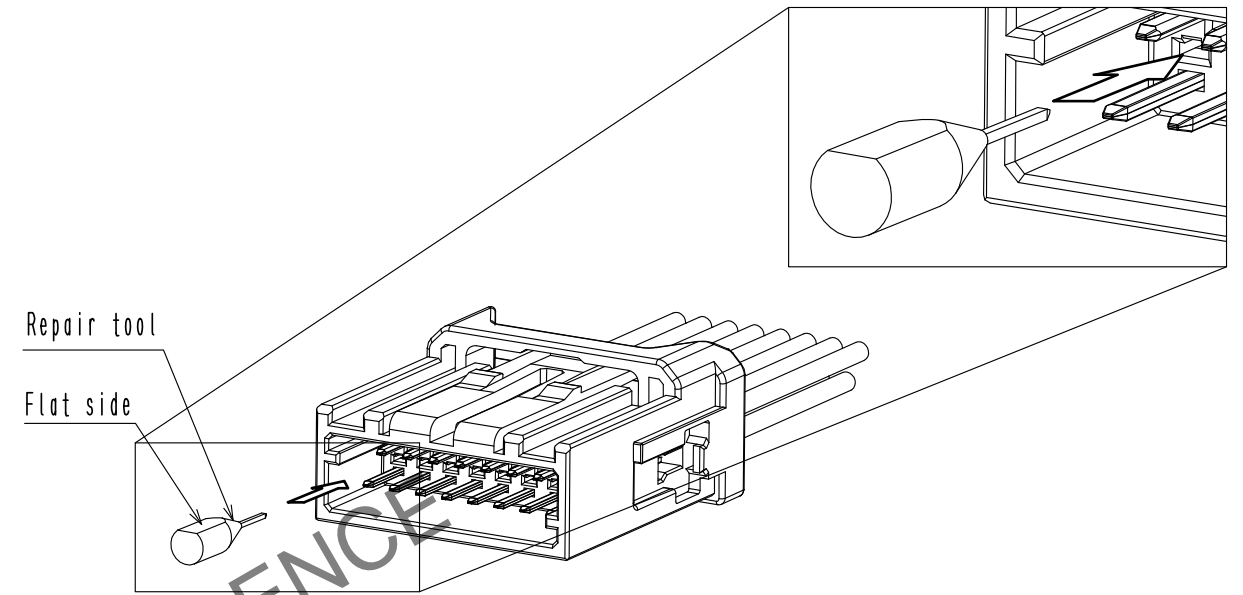

*Recommend to operate under proper illumination to enhance workability

Condition at inserted repair tool

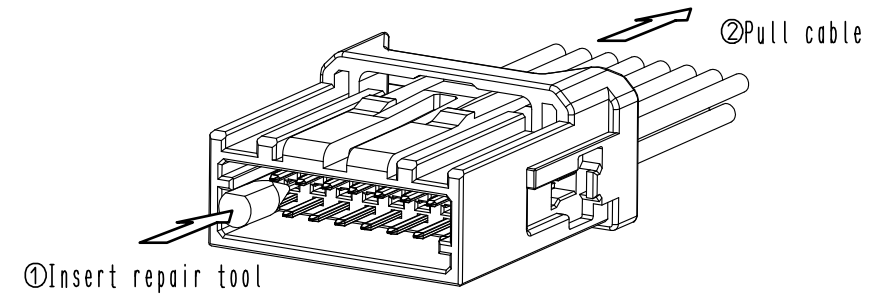

Note: Housing is not reusable. Please use new parts after repairing.

Note: In case the terminal lance and/or retainer lance has been deformed, please use new parts.

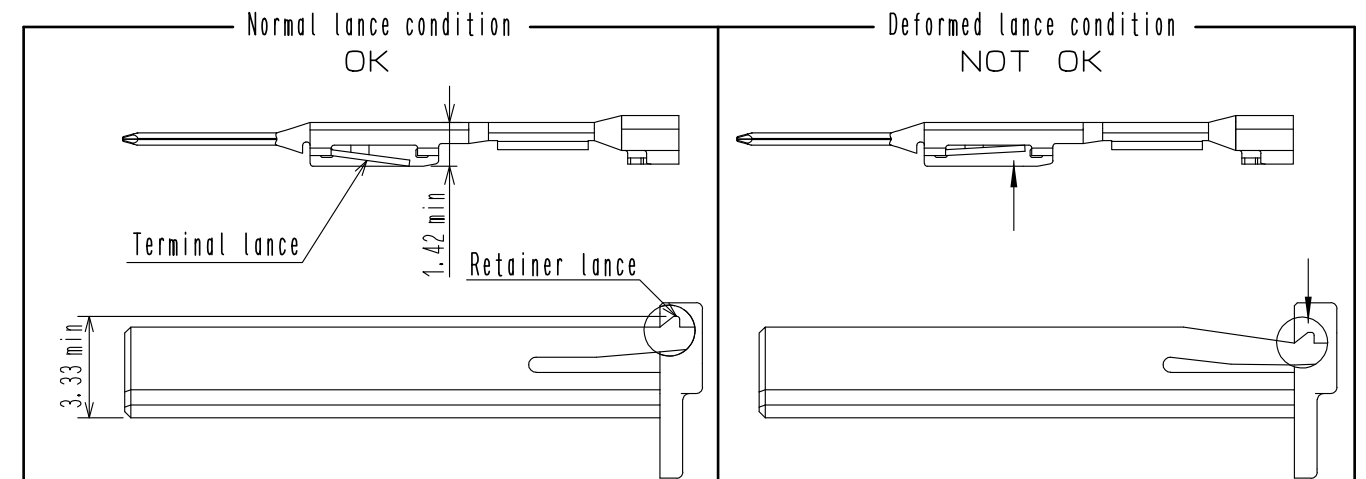

HRS	DRAWING NO.	EDC-399092-00-00
	PART NO.	ZH05-32DP-HU(B)
	CODE NO.	CL0756-2219-0-00
		3/4

In case of consideration for using Automotive equipment / device which demand high reliability, kindly contact our sales window correspondents.

Aug.1.2024 Copyright 2024 HIROSE ELECTRIC CO., LTD. All Rights Reserved.

Aug.1.2024 Copyright 2024 HIROSE ELECTRIC CO., LTD. All Rights Reserved.
In case of consideration for using Automotive equipment / device which demand high reliability, kindly contact our sales window correspondents.

4. Other / Notes

- 1) Do not touch the terminal contact points or the interior of the barrel.
- 2) In the event that the terminal must be handled, please wear gloves in order to prevent corrosion.
- 3) Placing items on top of a terminal or dropping a terminal may result in shape deformities or contamination. Please handle terminals with care.
- 4) In the event of terminals becoming tangled, please do not forcibly pull or bend them apart, but disentangle them carefully.
- 5) Use caution when handling terminals so as to avoid deformation.
- 6) Make sure that the terminals of crimped cables do not become entangled. When bundling or stacking cables, please prevent the terminals from being subjected to any external force.
- 7) Use caution to ensure that the part is not subjected to any large impacts.
- 8) Avoid storing in dusty areas.
- 9) Do not place wire harnesses on the floor.
- 10) Refrain from any handling that may result in terminal damage or deformation.
- 11) Do not use if the housing is dropped.

Repair tool summary

Retainer repair tools - Part Number Summary

Applicable Part	Repair Tool Name	Repair Tool Part Number
ZH05-##DP-HU(##)	ZH05/R/RE-MD	902-5162-0

(##) =specification number

Crimp Terminal crimping tool - Part Number Summary

Applicable Part	Connection Tool Name	Connection Tool Part Number
ZH05-2224PCF(##)	applicator AP105-ZH05-2224P	901-5253-0

(##) =specification number

Crimp Terminal repair Tool - Part Number Summary

Applicable Part	Repair Tool Name	Repair Tool Part Number
ZH05-2224PCF(##)	ZH05/RE-MD	902-5161-0

(##) =specification number

5. CRIMP QUALITY STANDARD

1. Scope

This technical specification prescribes crimp condition of ZH05-2224PCF (CL756-2001-0)

2. Applicable wire

- Applicable wire size : 0.22~0.35SQ
- Applicable insulation size : $\phi 0.9 \sim \phi 1.4$

3. Quality standard

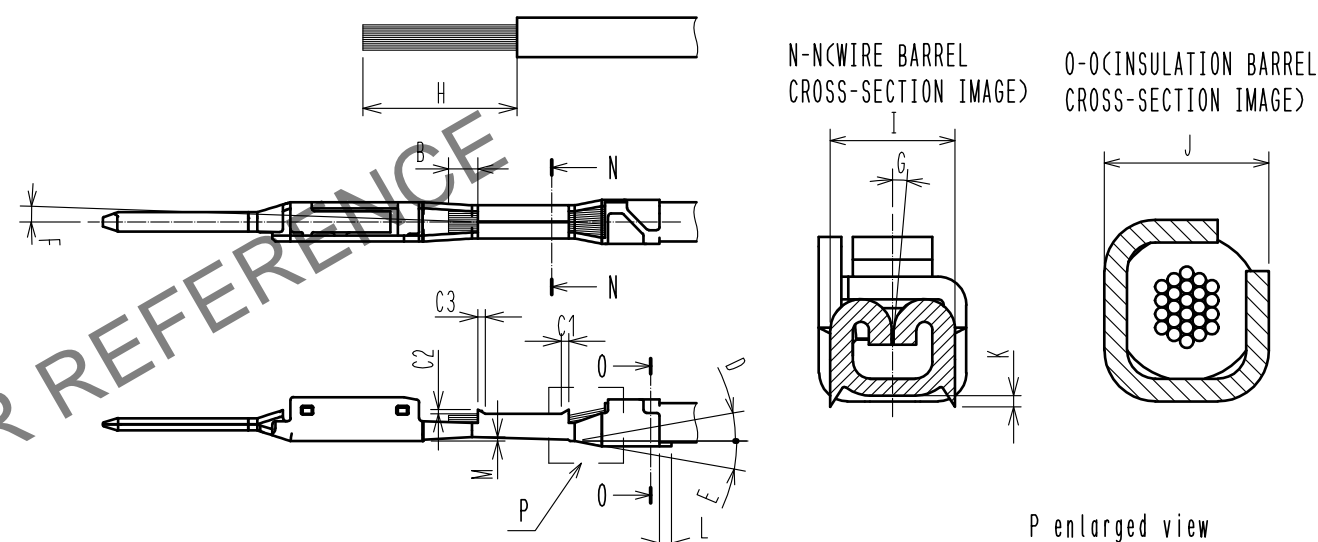

CHECK POINT	MEASURE (mm)
COVER LOCATION	A 0.3~0.8
LOCATION OF TIP OF THE CORE	B 0.1~0.6
BELL-MOUTH	C1 0.1~0.4
	C2 0.1 max
	C3 0.15 max
BEND-UP	D 2° max
BEND-DOWN	E 3° max
TWIST	F $\pm 2^\circ$ max
ROLLING	G $\pm 5^\circ$ max
STRIP LENGTH	H 4.0~4.6
WIDTH	WIRE BARREL I 1.36 max
	INSULATION BARREL J 1.47 max
HEIGHT OF METAL CUT-OUT TEETH	K 0.15 max
CUT-OFF TAB	L 0.1 max
DIFFERENCE IN LEVEL ON TRANSITION PART APPLY ONLY BEND-UP	M 0.2 max
DIFFERENCE IN LEVEL BETWEEN WIRE BARREL AND INSULATION BARREL	Q 0.2~0.25
DISTANCE BETWEEN WIRE-CRIMPER AND WIRE-ANVIL	R 0.15~0.31

Note1. Refer to a crimp condition list for the crimp height.

Note2. A barrel may nip at insulation after crimping, but there is no problem in product function.

Note3. Please confirm that the terminal which did crimp enters a housing.

HRS

DRAWING NO. EDC-399092-00-00
PART NO. ZH05-32DP-HU(B)
CODE NO. CL0756-2219-0-00

4/4