

Jun.1.2024 Copyright 2024 HIROSE ELECTRIC CO., LTD. All Rights Reserved.
 In case of consideration for using Automotive equipment / device which demand high reliability, kindly contact our sales window correspondents.

ELV, RoHS COMPLIANT

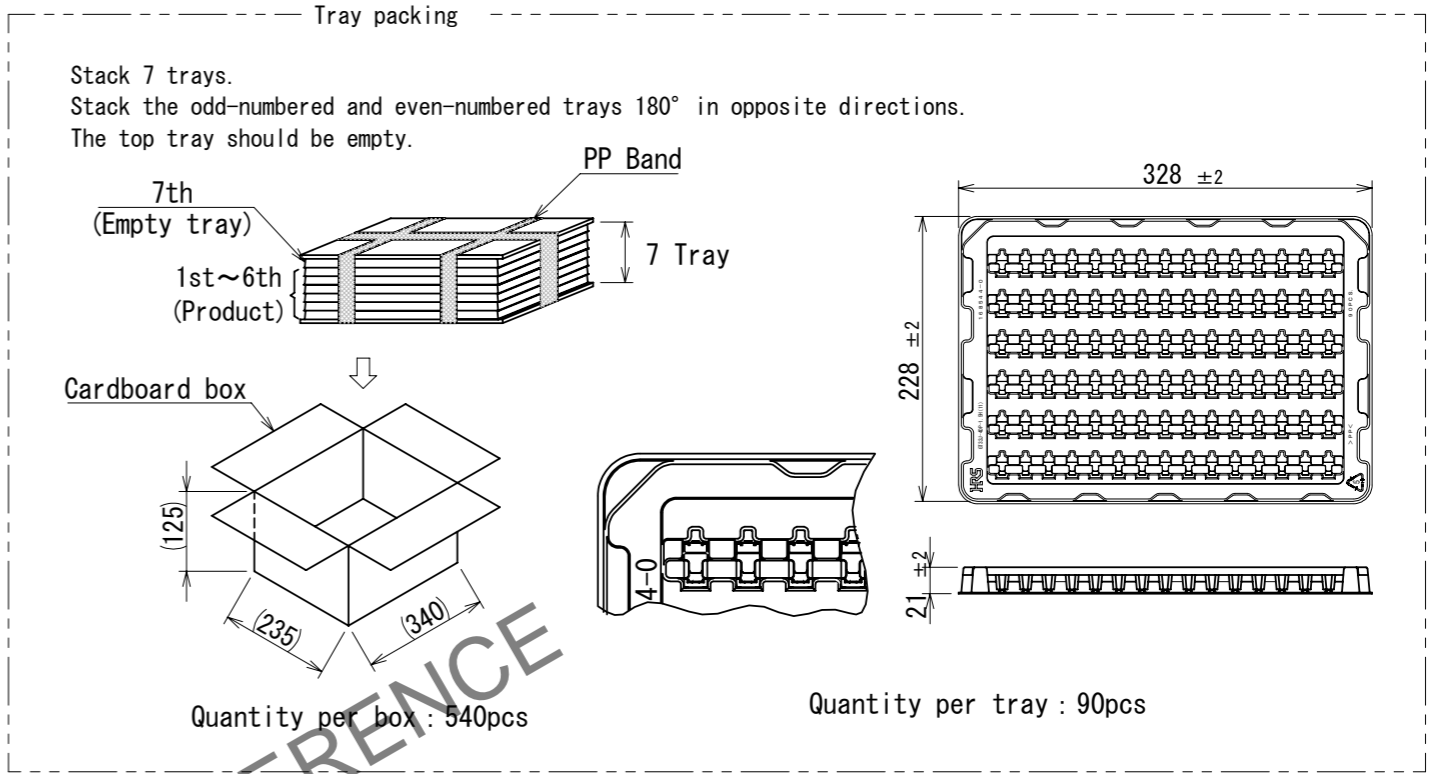

Mounting and mating state

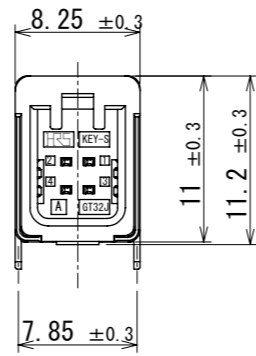
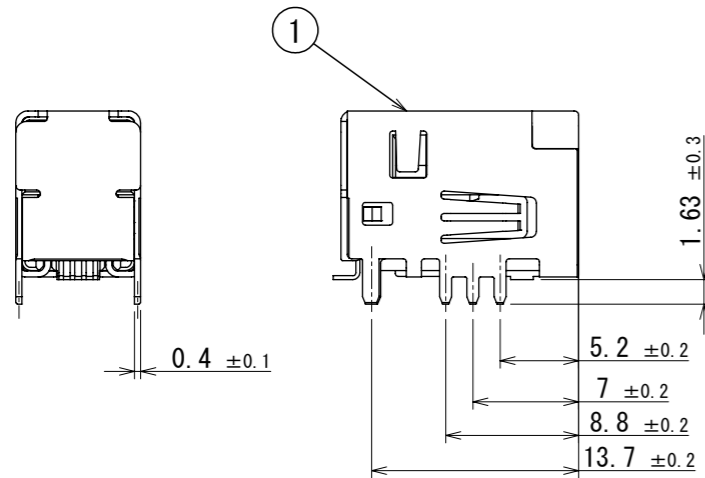
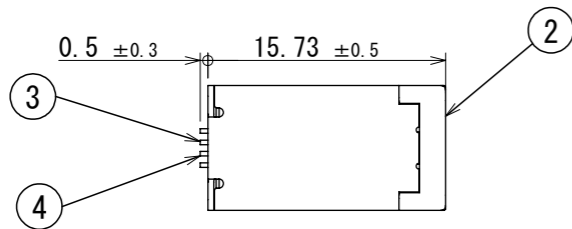
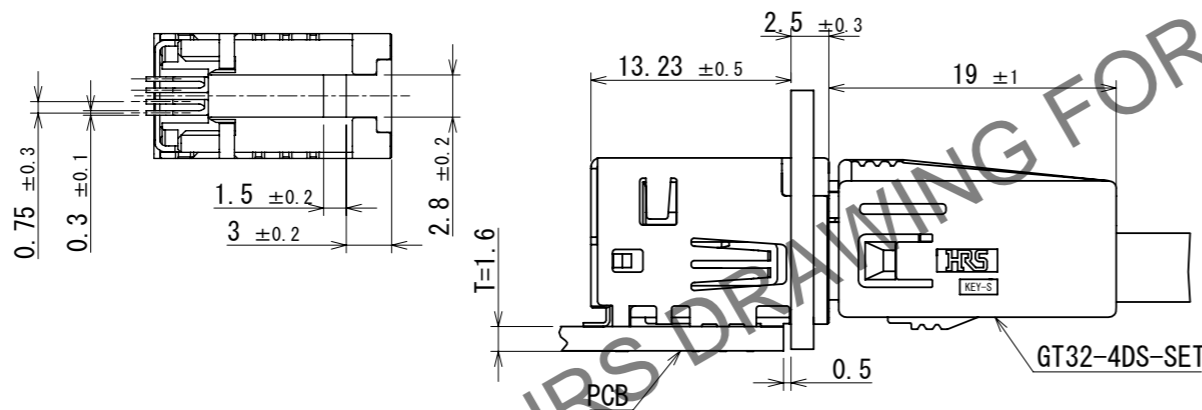

NOTES

- Recommended temperature profile (see graph on the right)
 Number of reflow times : 2 times
 Peak temperature : 250°C
 230° C or higher : 20 to 40s
 Preheat temperature : 150 to 180°C, 60 to 120s
- Hand soldering / soldering iron temperature:
 280 to 300°C, within 2s.
- Terminal coplanarity 0.1mm MAX
- Recommended PCB thickness: T=1.6mm.
- Recommended solder paste thickness: 0.12mm.
- ⊗ in the Recommended land pattern (3:1) is the pattern prohibited area.
- When routing the cable, secure the cable with appropriate position so that the wiring harness should not be pried or shaken by vibration.

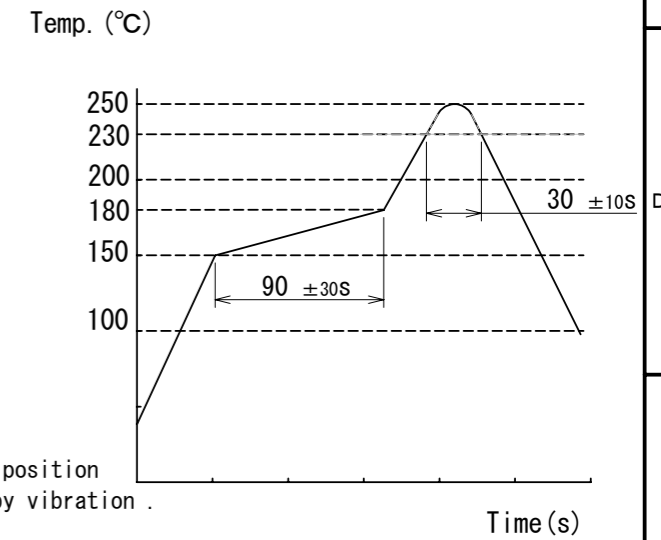

Recommended land pattern (3:1)

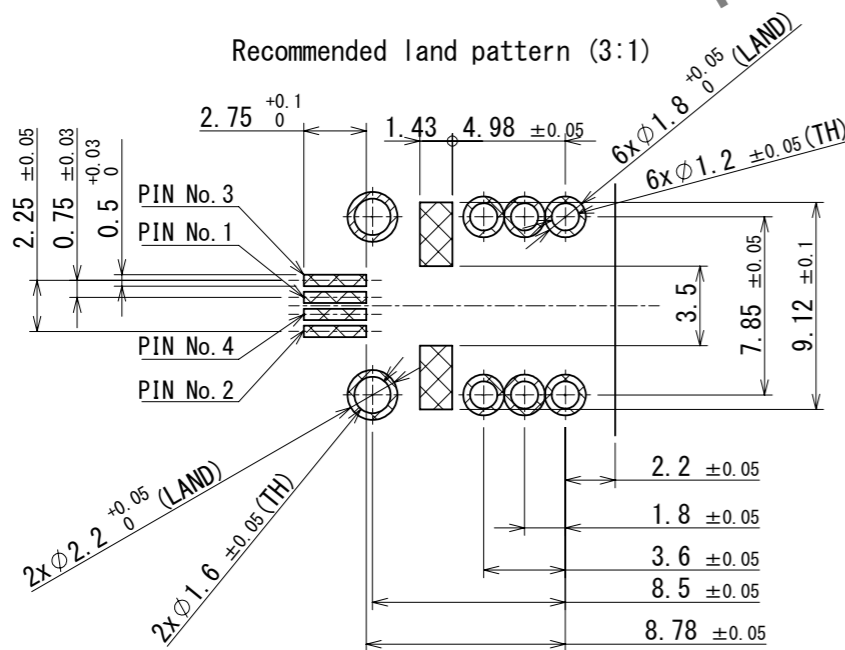

Panel size

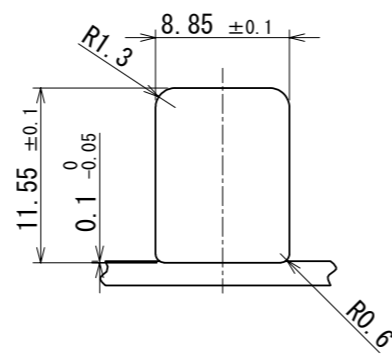

2	PA	DARK GRAY	4	BRASS	TIN PLATING								
1	COPPER ALLOY	TIN PLATING	3	BRASS	TIN PLATING								
NO.	MATERIAL	FINISH	REMARKS	NO.	MATERIAL	FINISH	REMARKS						
UNITS	mm	SCALE	2:1	COUNT	0	DESCRIPTION OF REVISIONS	DIS-T-00018419						
DESIGNED				KN. YANAGIMOTO		CHECKED		EJ. WAKATSUKI		DATE		2023.06.19	
APPROVED				KI. HIROKAWA		2021.12.16		DRAWING NO.		EDC-393578-11-00			
CHECKED				EJ. WAKATSUKI		2021.12.16		PART NO.		GT32J-4DP-1.5H(11)			
DESIGNED				YK. KANNO		2021.12.16		CODE NO.		CL0782-0085-0-11			
DRAWN				YK. KANNO		2021.12.16							