

TITLE:	BK13C06 Series Guideline	REVISION DATE: 10-Jan-19 Version 2.0
OBJECT PRODUCT:	BK13C06 SERIES CONNECTOR BOARD TO FPC, 0.35mmPITCH	PAGE: 1 OF 14

BK13C06 Series Guideline for Designing and Handling

Version	2.0
Author	
Checked	
Approver	

Change History

Version	Date	Handled by	Comments
1.0	2019/01/10	S.H.JUNG	1 st draft
2.0	2019/01/14	S.H.JUNG	Add contents in connector withdrawing operation
3.0			
4.0			
5.0			

TITLE:	BK13C06 Series Guideline	REVISION DATE: 10-Jan-19 Version 2.0
OBJECT PRODUCT:	BK13C06 SERIES CONNECTOR BOARD TO FPC, 0.35mmPITCH	PAGE: 2 OF 14

TABLE OF CONTENTS

Page Number

1.	Notice for Device Designing	3
	1.1 Notice for mechanical designing.....	3
	1.1.1 Disengaging prevention	3
	1.1.2 FPC fixing	4
	1.1.3 Allocation of other components around connector	4
	1.1.4 Marking for mating position	4
	1.2 Notice for PWB designing.....	5
	1.2.1 Recommended PWB layout	5
	1.2.2 PWB pad layout and connector location	5
	1.2.3 PWB designing	6
	1.2.4 FPC designing	6
2.	Notice for Mounting	7
	2.1 Metal mask design.....	7
	2.2 Fillet forming.....	8
	2.3 Reflow profile	9
	2.4 Repair condition.....	10
3.	Notice for Connector Handling	11
	3.1 Connector inserting operation	11
	3.2 Connector withdrawing operation	12
4.	PWB and Solder Paste for Evaluation Test	13
	4.1 PWB for evaluation test.....	13
	4.2 Solder paste for evaluation test.....	14

TITLE:	BK13C06 Series Guideline	REVISION DATE: 10-Jan-19 Version 2.0
OBJECT PRODUCT:	BK13C06 SERIES CONNECTOR BOARD TO FPC, 0.35mmPITCH	PAGE: 3 OF 14

1 Notice for Device Designing

1.1 Notice for mechanical designing

1.1.1 Disengaging prevention

There is a possibility that connectors are disengaged if strong impact, such as dropping, is put against connectors in use. In order to prevent connectors from disengaging, please make sure to put buffer material between a connector and a cover case to hold down the connector pair to the mating direction. (Please refer to Figure 1-1-1-a)

If a connector is directly pressed down by a cover case, there is a possibility that the cover case is bent and it may cause connector disengagement when the device is dropped. Please avoid a design that the connector is directly pressed by cover case, instead, use put the buffer material to press down the connector. (Please refer to Figure 1-1-1-b)

Buffer material must be the size which is able to cover all over the connector mounting area.

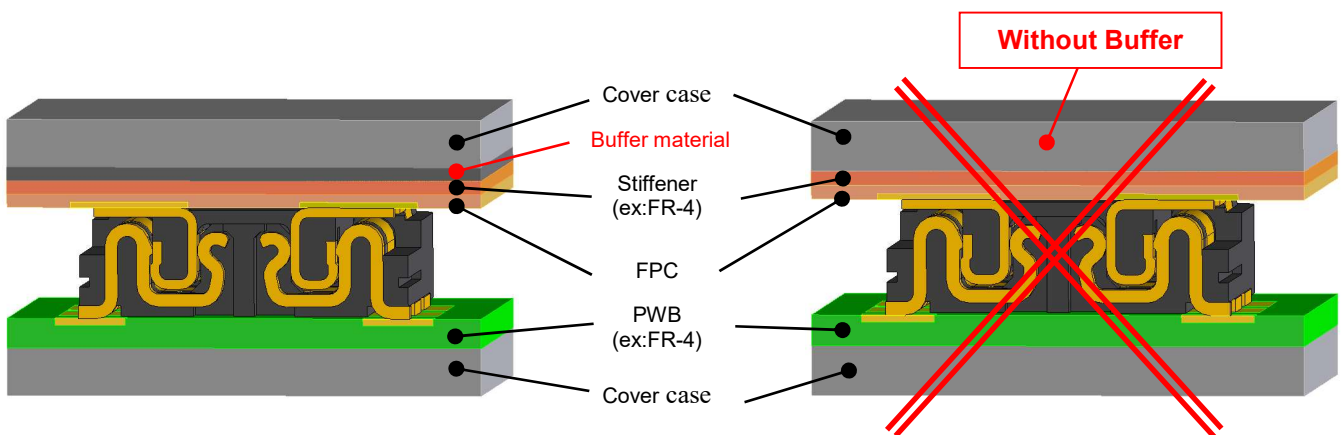

Figure 1-1-1-a

Figure 1-1-1-b

TITLE:	BK13C06 Series Guideline	REVISION DATE: 10-Jan-19 Version 2.0
OBJECT PRODUCT:	BK13C06 SERIES CONNECTOR BOARD TO FPC, 0.35mmPITCH	PAGE: 4 OF 14

1.1.2 FPC fixing

If FPC position is fixed, connector will get direct stress from dropping impact. Please do not design FPC positioning bosses which prevent flexibility of FPC.
(Please refer to Figure 1-1-2)

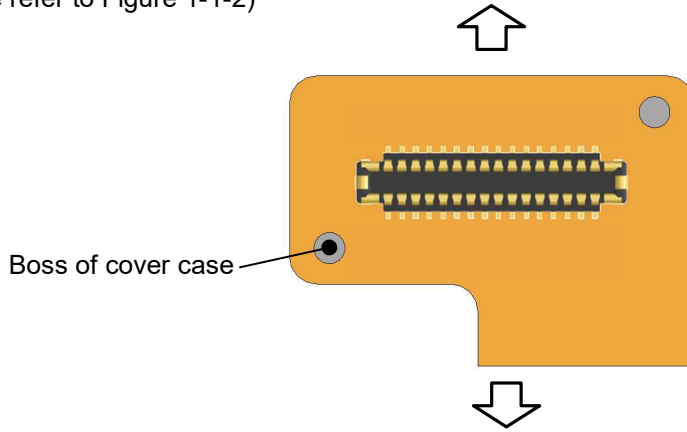

1-1-2: If FPC is fixed by boss of a cover case, there will be no flexibility for 4 dimension indicated by arrows.

1.1.3 Allocation of other components around connector

Please do not locate any material which may affect on connector mating around the connectors.

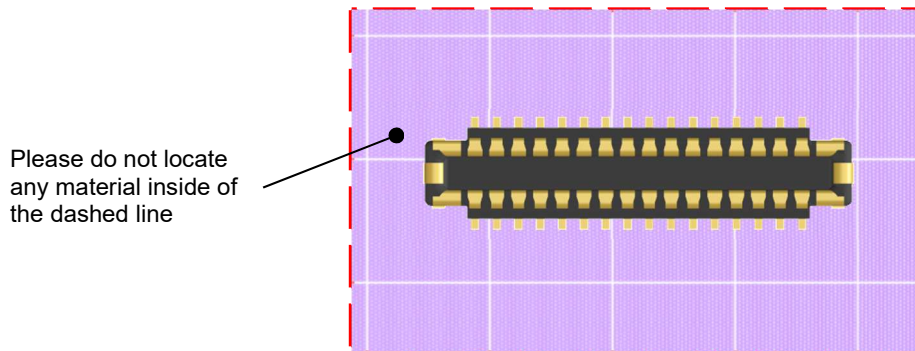

1.1.4 Marking for mating position

When mating a connector on the FPC side against the other side manually, in order to operate mating in the appropriate position without misalignment, please put some marking to indicate the exact mating position on the PWB.

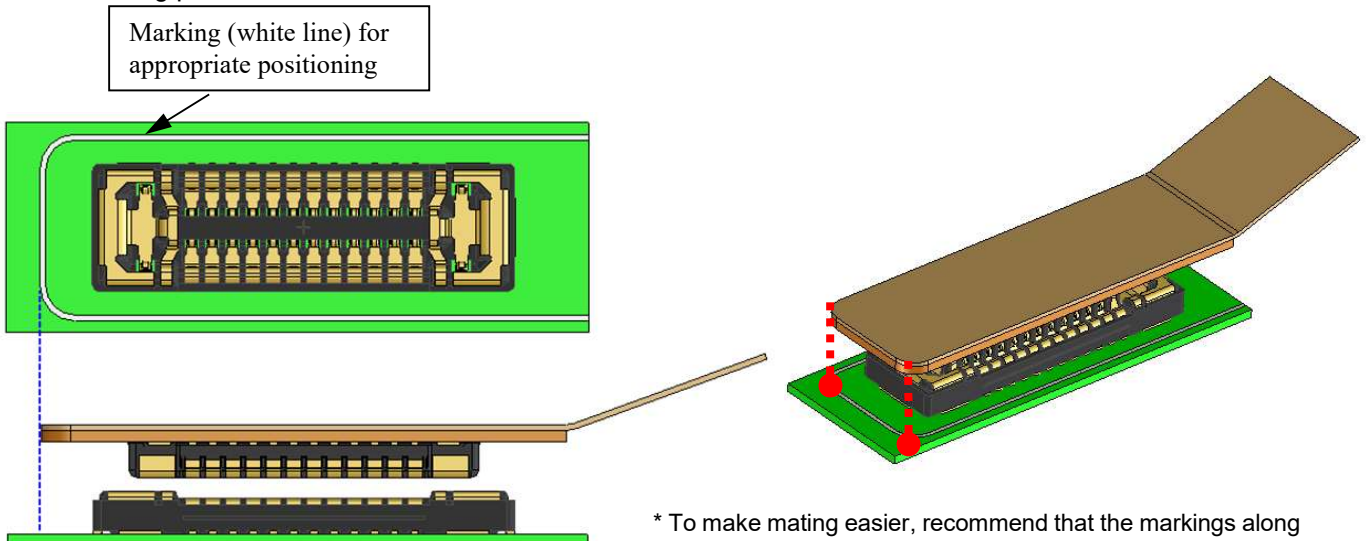

* To make mating easier, recommend that the markings along the outline of the FPC on the PWB.

TITLE:	BK13C06 Series Guideline	REVISION DATE: 10-Jan-19 Version 2.0
OBJECT PRODUCT:	BK13C06 SERIES CONNECTOR BOARD TO FPC, 0.35mmPITCH	PAGE: 5 OF 14

1.2 Notice for PWB designing

1.2.1 Recommended PWB pattern

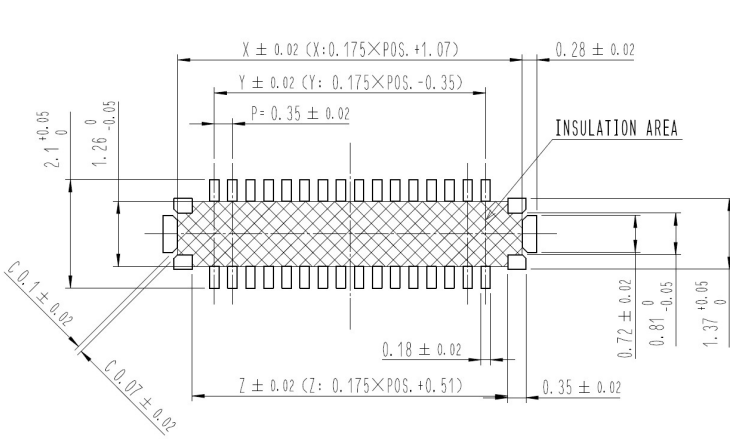

Header side recommended PWB pattern

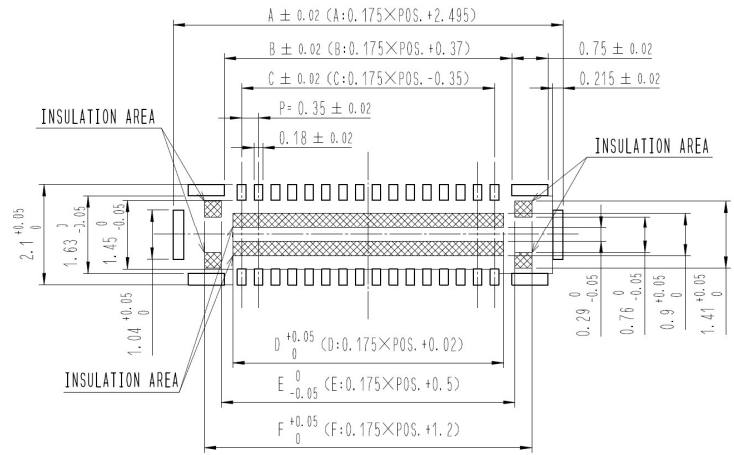

Receptacle side recommended PWB pattern

1.2.2 PWB pad layout and connector location

Plug

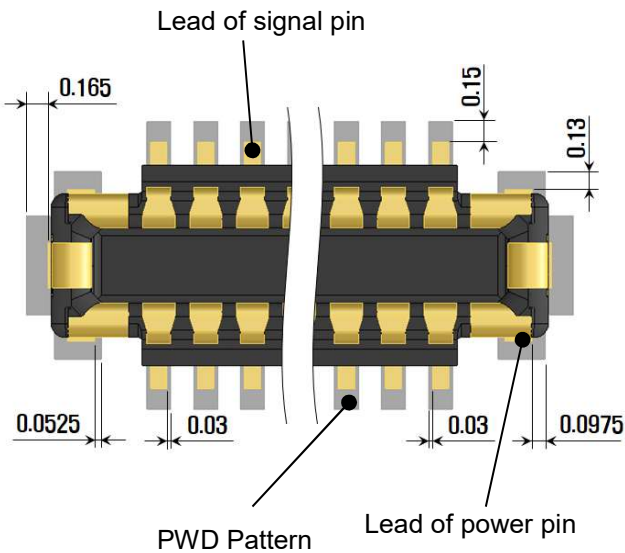

Receptacle

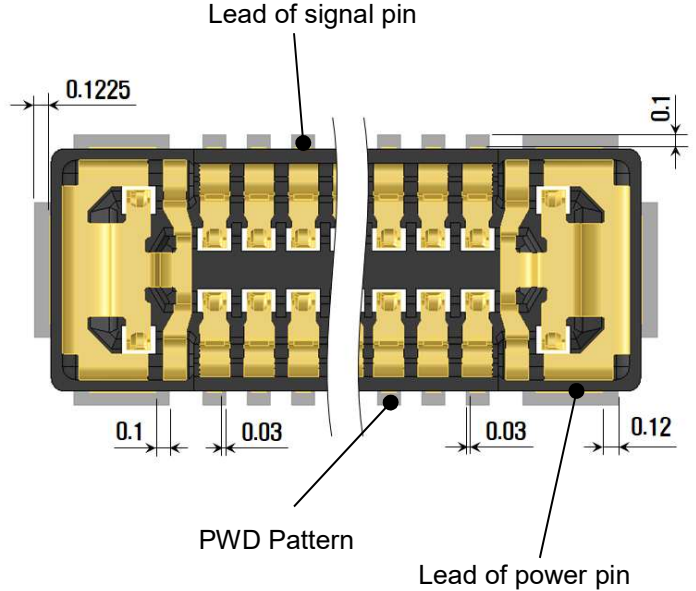

TITLE:	BK13C06 Series Guideline	REVISION DATE: 10-Jan-19 Version 2.0
OBJECT PRODUCT:	BK13C06 SERIES CONNECTOR BOARD TO FPC, 0.35mmPITCH	PAGE: 6 OF 14

1.2.3 PWB designing

-Please design PWB layout properly so that front fillet, back fillet and side fillet are formed.
The recommended PWB layout is designed so that the connector can be soldered to the PWB appropriately.

-If the pad layout is not wide enough, there is a possibility that solder wicking or flux splashing may occur.
Please contact and discuss with us if the PWB layout is different from the recommended PWB layout.

-As for receptacle side, if there is not enough clearance on the inner side of PWB pattern, there is a possibility that the connector is pushed up by solder paste.

-In case those patterns are designed under a connector, there is a possibility to cause solder failure if there are physical height. Especially, in the following case, please conduct mounting test for the check.

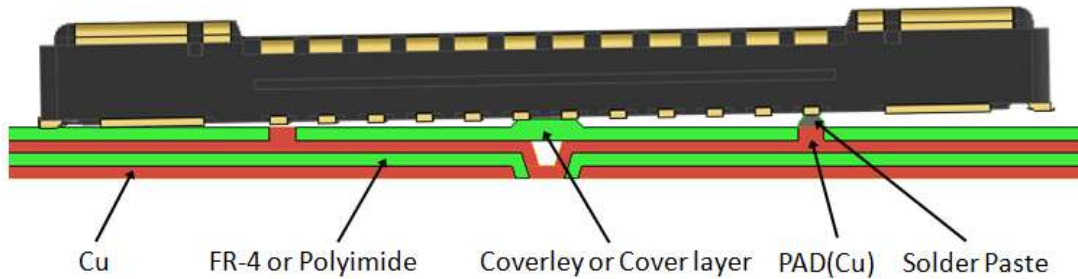

1.2.4 FPC designing

-FPC can be bent due to the diversity of coefficient thermal expansion of polyimide and copper foil.
Please mount the connector in consideration of bending by heating.

-Please make sure to put a stiffener on the backside of the FPC. If polyimide is used as material, it is preferable to be as thick as possible. We recommend a glass epoxy material with the thickness of 0.3mm MIN, or a stainless material with the thickness of 0.2mm MIN.

<Note> Please let us know if you are considering using thinner PWB than the one we recommend. If a receptacle is mounted on thinner FPC, insertion area would be harder than usual.

TITLE:	BK13C06 Series Guideline	REVISION DATE: 10-Jan-19 Version 2.0
OBJECT PRODUCT:	BK13C06 SERIES CONNECTOR BOARD TO FPC, 0.35mmPITCH	PAGE: 7 OF 14

2 Notice for Mounting

2.1 Metal mask design

Recommended metal mask dimension for Receptacle and Plug

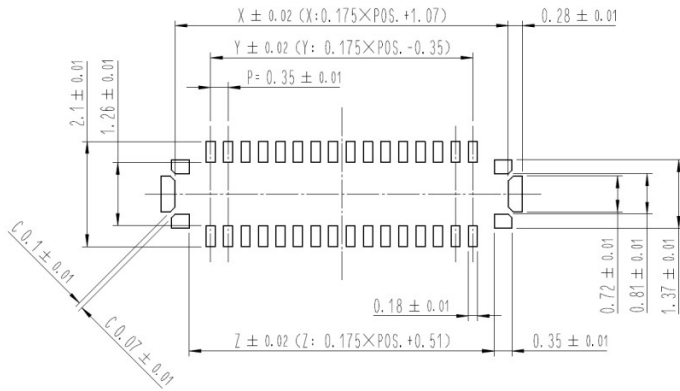

Recommended metal mask for Plug

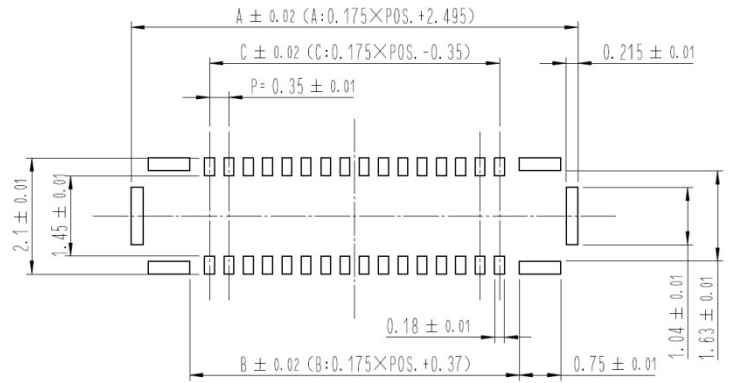

Recommended metal mask for Receptacle

Aperture ratio

Receptacle : Signal Contact 100%, Power Contact 100%

Plug : Signal Contact 100%, Power Contact 100%

Recommended metal mask thickness:

Receptacle : 80 μm

Plug : 80 μm

TITLE:	BK13C06 Series Guideline	REVISION DATE: 10-Jan-19 Version 2.0
OBJECT PRODUCT:	BK13C06 SERIES CONNECTOR BOARD TO FPC, 0.35mmPITCH	PAGE: 8 OF 14

2.2 Fillet forming

1) Fillet forming on Receptacle

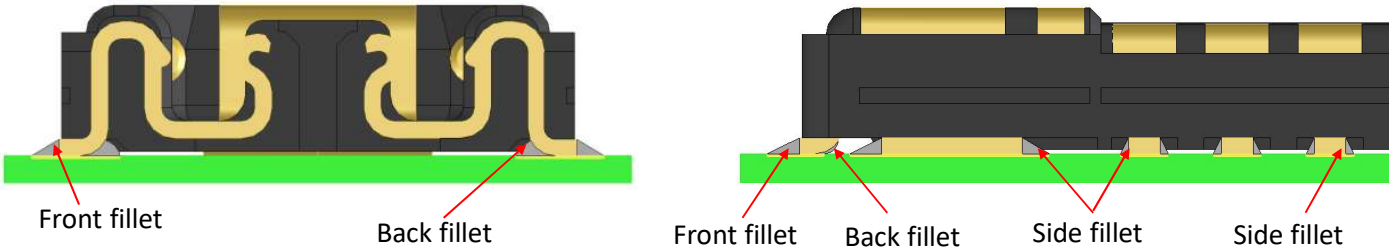

2) Fillet forming on Plug

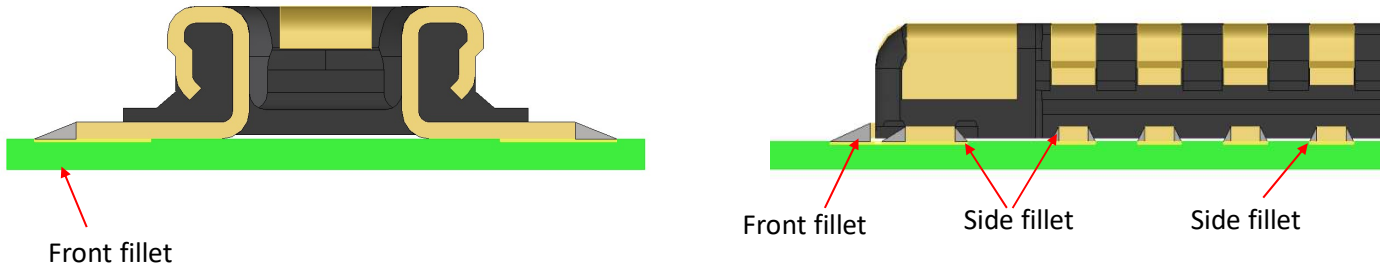

Likewise the other (receptacle) side, as the contact lead edge, on where "front fillet" is formed is a metal cut surface, copper alloy is exposed. The exposed area is easy to process thermal oxidation from reflow heating, so it is difficult for soldering paste to get wet and be spread over the area. If the fillet formation needs to be judged defective/not defective, please judge by "side fillet" forming.

TITLE:	BK13C06 Series Guideline	REVISION DATE: 10-Jan-19 Version 2.0
OBJECT PRODUCT:	BK13C06 SERIES CONNECTOR BOARD TO FPC, 0.35mmPITCH	PAGE: 9 OF 14

2.3 Reflow profile

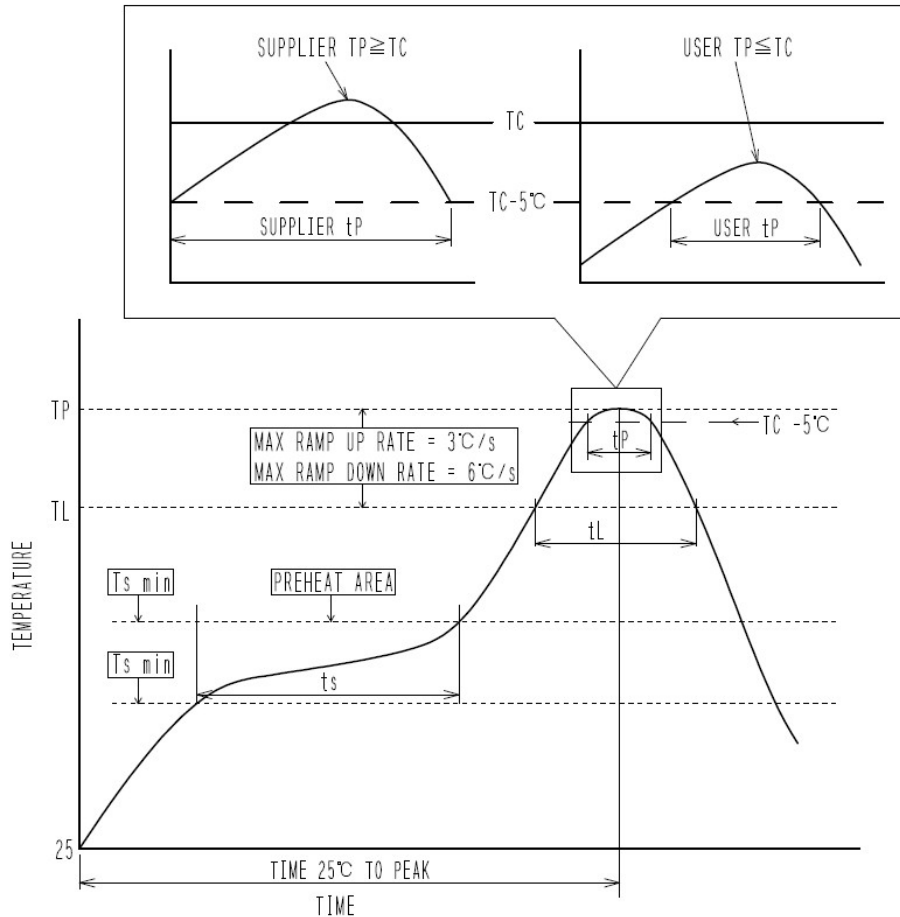

-Profile measuring point

The temperature profile indicates the board surface temperature at the point of contacts with the connector terminals.

-Reflow cycles

Up to 3 cycles of reflow soldering are possible under the same conditions.

*Temperature between 1st and 2nd reflow must be cooled down to room temperature.

*Temperature between 2st and 3rd reflow must be cooled down to room temperature.

-Reflow heating method and condition

Far-infrared heater and hot convective blowers used in combination,
nitrogen atmosphere

***Notice for reflow in nitrogen atmosphere**

Please make oxygen density at assembly over 1000ppm (HRS recommend).

Please contact and discuss with us if it is under 1000ppm.

TITLE:	BK13C06 Series Guideline	REVISION DATE: 10-Jan-19 Version 2.0
OBJECT PRODUCT:	BK13C06 SERIES CONNECTOR BOARD TO FPC, 0.35mmPITCH	PAGE: 10 OF 14

2.4 Repair Condition

Receptacle

Repairing condition:

- Soldering iron 350°C, 3seconds MAX Notice:
- Please do not put stress on contacts.
- Please do not touch housing with a soldering iron.

Header

Repairing condition

- Soldering iron 350°C, 3seconds MAX Notice:
- Please do not put stress on contacts.
- Please do not touch housing with a soldering iron.
- Please protect contact from flux or soldering paste splashing (ex. set a cover over the contact area).

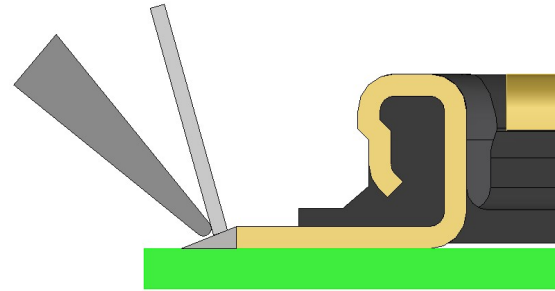
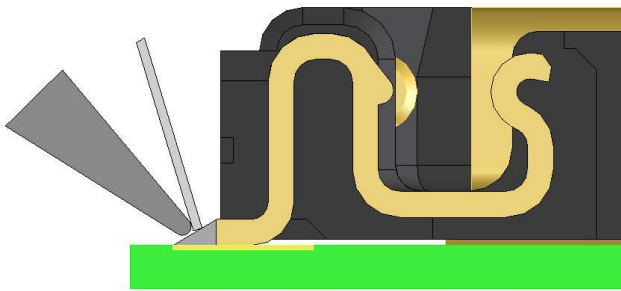

2-5 Solder swelling

Please keep the soldering paste height less than 0.05mm.
It may effect on the board to board distance.

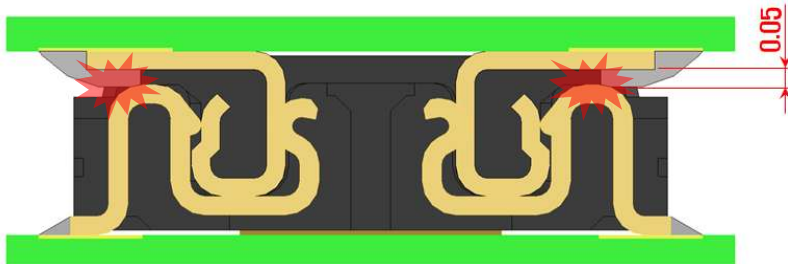

TITLE:	BK13C06 Series Guideline	REVISION DATE: 10-Jan-19 Version 2.0
OBJECT PRODUCT:	BK13C06 SERIES CONNECTOR BOARD TO FPC, 0.35mmPITCH	PAGE: 11 OF 14

3. Notice for Connector Handling

3.1 Connector inserting operation

Please mate connectors by hands.
Manual for inserting operation

- 1) Find the alignment area with hand to locate the connector in the appropriate mating position. This connectors have alignment chamber on receptacle side and R on plug side, so that the connector can be self-aligned

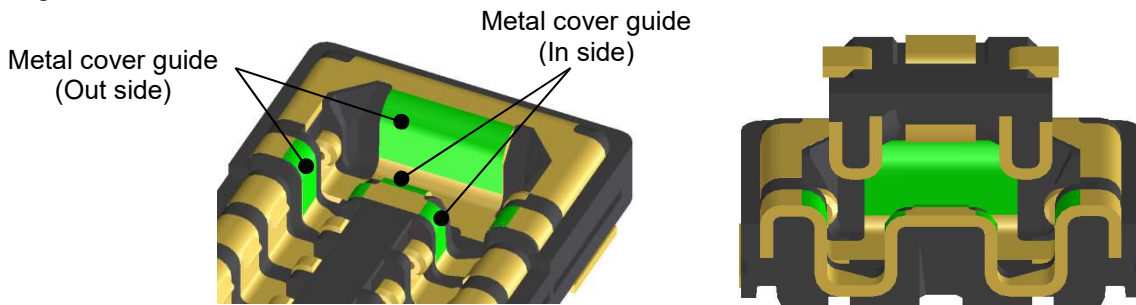

- 2) When the connector comes to the appropriate position, the connector comes into the aligned position. If the connector comes into aligned position, it can be recognized by hand that the connector goes down one level.

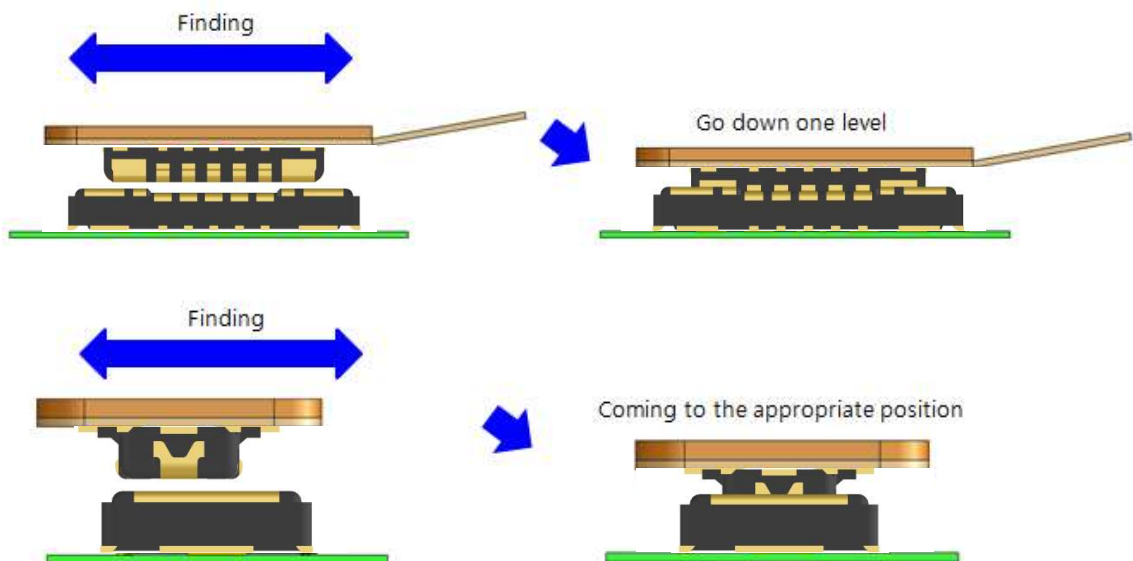

- 3) When the connectors are in alignment position, the connector pair cannot be moved back and forth and around as they are mated in a parallel position. Please make the connectors completely, by putting force in this condition.



- 4) Please make sure connectors are mated completely. If one side is floating or the connectors are mated at a slant, please do not mate once, and then mate them once again, following the procedures above from the beginning.

TITLE:	BK13C06 Series Guideline	REVISION DATE: 10-Jan-19 Version 2.0
OBJECT PRODUCT:	BK13C06 SERIES CONNECTOR BOARD TO FPC, 0.35mmPITCH	PAGE: 12 OF 14

3.2 Connector withdrawing operation

1) Withdrawing vertically

It is desirable to withdraw the connector in the vertical direction against mating direction. However, in the mating of PWB to FPC, the more pins the connectors have, or the thinner the FPC becomes, the more difficult to withdraw the connector in the vertical direction.

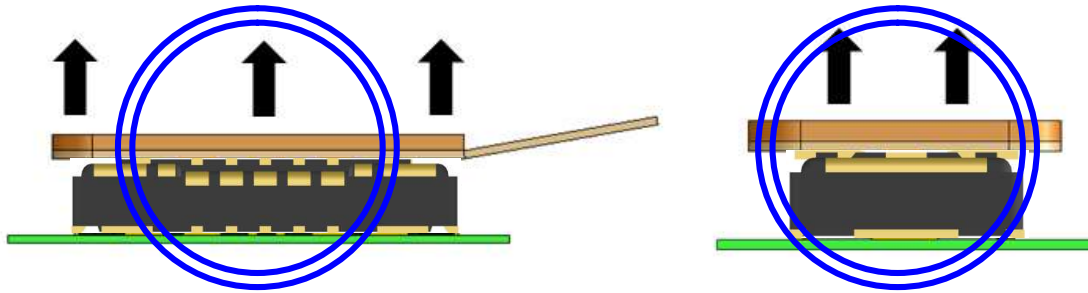

2) Withdrawing on the angle:

If it is difficult to withdraw the connector, please withdraw the connector diagonally against the contact pitch direction. Please do not withdraw the connector against the width direction because the contacts can get strong stress. Please avoid withdrawing the connector from width side. It may damage the contacts. When removing from width side, please pull both ends parallel to the mating direction

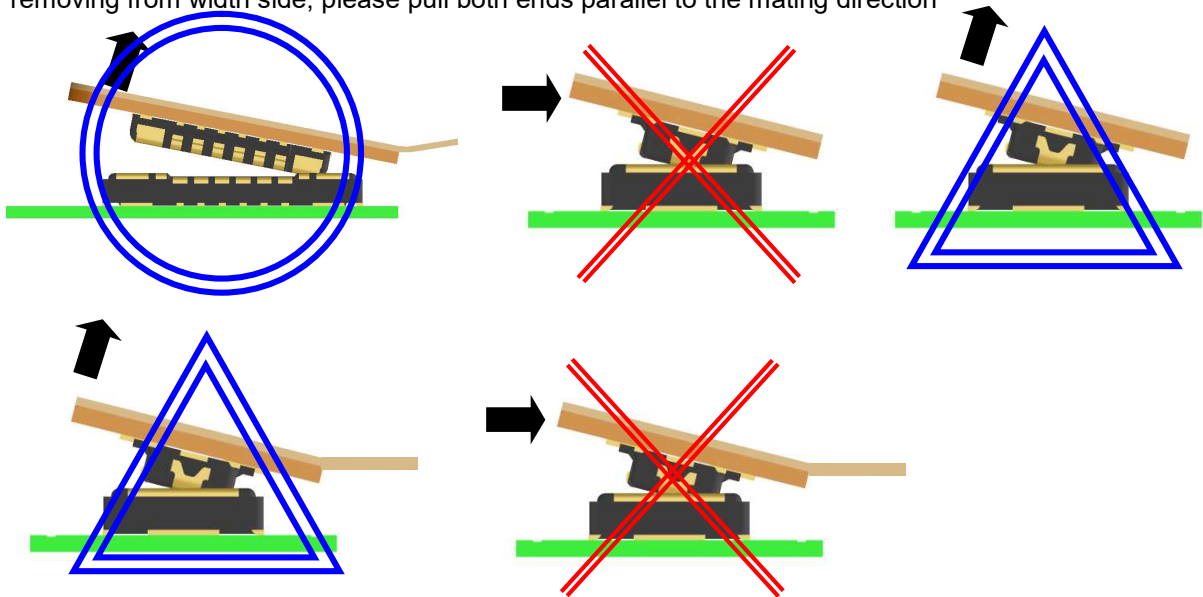

3) Other cautions

If the FPC is not strong enough, there is a possibility that contacts may be pulled off or broken. Please make sure to conduct the test on FPC to repeat operation several times in an early stage build. Please do not withdraw the connector in the slanted direction, picking the FPC corner, as it can be a risk to put a strong load on contacts.

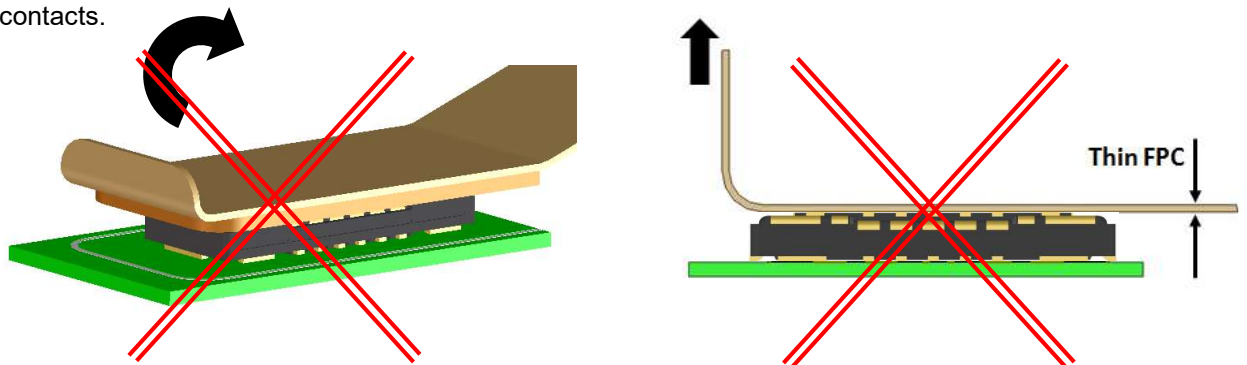

TITLE:	BK13C06 Series Guideline	REVISION DATE: 10-Jan-19 Version 2.0
OBJECT PRODUCT:	BK13C06 SERIES CONNECTOR BOARD TO FPC, 0.35mmPITCH	PAGE: 13 OF 14

4. PWB and Solder Paste for Evaluation Test

4.1 PWB for evaluation test

1) For contact resistance

Thickness of copper foil : 35 μm

◆ FR-4 PWB for Receptacle

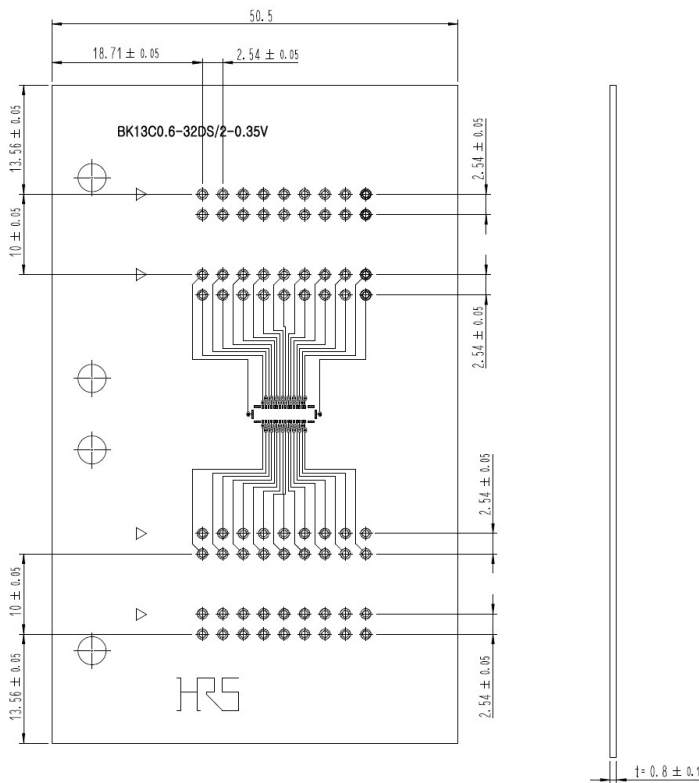

◆ FPCB for Header

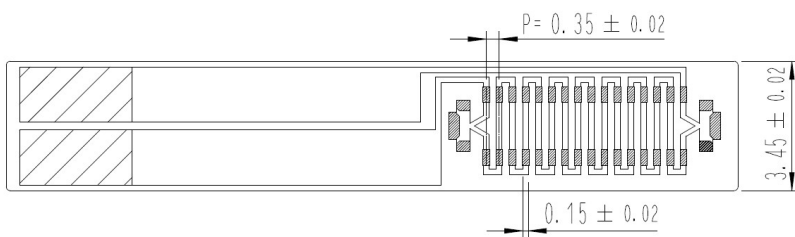

◆ FPC Material Configuration

LAYER	MATERIAL	THICKNESS(μm)	
RESIST	INK	15	
Cu FOIL		35	
ADHESIVE		20	
BASE FILM	POLYIMID	25	
ADHESIVE	Thermoplastic adhesive	40	TOTAL
STIFFENER	FR4	300	425~435

TITLE:	BK13C06 Series Guideline	REVISION DATE: 10-Jan-19 Version 2.0
OBJECT PRODUCT:	BK13C06 SERIES CONNECTOR BOARD TO FPC, 0.35mmPITCH	PAGE: 14 OF 14

2) For temperature rise

Thickness of copper foil : 35 μm

◆ FR-4 PWB for Receptacle

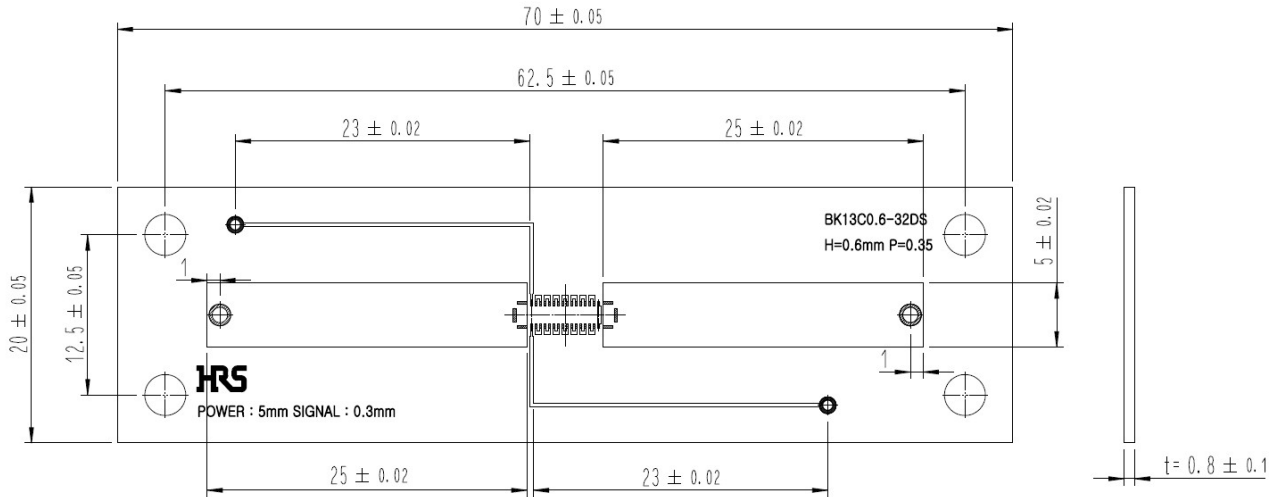

◆ FPCB for Header

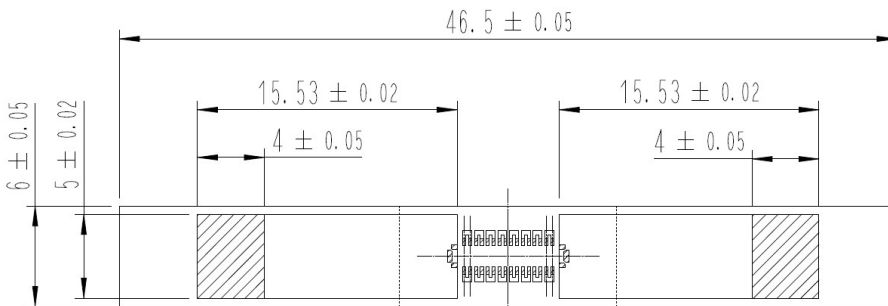

◆ FPC Material Configuration

LAYER	MATERIAL	THICKNESS(μm)	
RESIST	INK	15	
Cu FOIL		35	
ADHESIVE		20	
BASE FILM	POLYIMID	25	
ADHESIVE	Thermoplastic adhesive	40	TOTAL
STIFFENER	FR4	300	425~435

4.2 Solder paste for evaluation test

Pb free solder paste