

### Swing-Lock Structure explanatory drawing

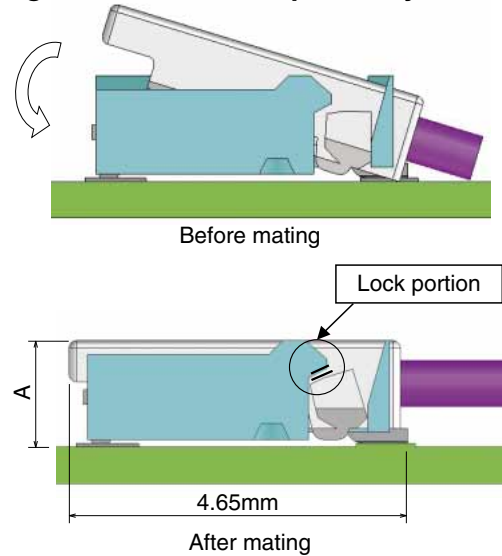

Mating Height A : DF57H 1.4mm  
DF57AH 1.6mm

Fig.1

## Features

### 1.Reinforced lock structure with swing lock

A swing-lock structure, featuring our own unique connection method, reinforces the lock structure of the electric cable side, with a structure resistant to tough electric cable routing and disengagement of cables under load.

In addition, the connection surface has a guide insertion to facilitate insertability (patented)

### 2.Header lock improves plug retention

When connecting, the header connector secures the molded-lance. Play of molded lance is prevented for added strength. (patented)

### 3.Highly reliable contact structure

Despite the low-profile design, with a stacking height of 1.4mm, an effective mating length of 0.42mm is achieved. The structure features two-point contact terminal geometry with high contact reliability.

### 4.Insert guide key prevents misalignment

Insert guide key guides the crimp socket to the correct mating position and prevents misalignment, which improves mating operation and prevents possible connector breakage with incorrect mating.

### 5.Solder wicking prevention

The integral molding eliminates any gap between the terminals and case to prevent solder wicking.

### 6.Case disengagement prevention

Reinforcing hardware (metal fittings) are integrated in the molding, which help prevent the case from disengaging with the terminals due to tough electric cable routing and load.

### 7.Cost effective

Terminals and metal fittings are collectively integrated into the molding to reduce assembly cost.

### Contact Structure

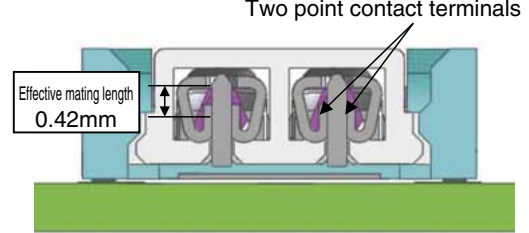

Cross-sectional view of the contact surface

Fig.2

### Incorrect Positioning

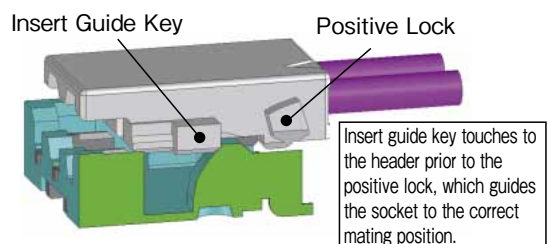

### Starts mating after the socket is aligned to the correct position

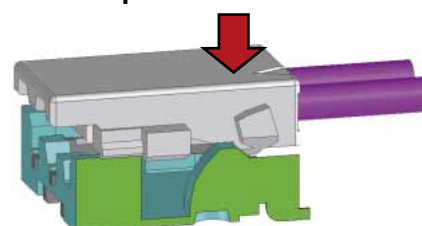

Insert Guide Key Structure

Fig.3

## Specifications

Rating	Current rating (Note 1)		2pos.	3pos.	4pos.	5,6pos.	Operating temperature range -35°C to 85°C (Note 2) Operating humidity range 20% to 80% (Note 3)
		AWG#26	3.0A/pin	—	1.5A/pin	1.5A/pin	
		AWG#28	2.5A/pin	2.0A/pin	1.5A/pin		
		AWG#30	1.5A/pin		1.0A/pin		
		AWG#32	1.0A/pin		0.8A/pin		
	AWG#34	0.8A/pin		0.5A/pin			
Voltage rating		2 to 6 pos. : 50V AC/DC 2 pos. (Middle pin of 3 pos. is removed) : 100V AC/DC				Storage temperature range -10°C to 60°C (Note 4) Storage humidity range 40% to 70% (Note 4)	

UL, C-UL certified specifications							
Rating	Current rating (Note 1)		2pos.	3pos.	4pos.	5,6pos.	
		AWG#26	3.0A/pin	—	1.5A/pin	1.5A/pin	
		AWG#28	2.5A/pin	2.0A/pin	1.5A/pin		
		AWG#30	1.5A/pin		1.0A/pin		
		AWG#32	1.0A/pin		0.8A/pin		
	AWG#34	0.8A/pin		0.5A/pin			
Voltage rating		2 - 6 pos. : 29V AC/DC					

Item	Specification	Conditions
1. Insulation resistance	100MΩ min.	100V DC
2. Withstanding voltage	No flashover or insulation breakdown	500V AC / 1 minute
3. Contact resistance	10mΩ max.	20mV max., at 1mA.
4. Vibration	No electrical discontinuity of 1μs or longer No damage, cracks or parts dislocation.	Frequency : 10 to 55Hz, single amplitude of 0.75mm, 10 cycles, 3 direction
5. Shock	No electrical discontinuity of 1μs or longer No damage, cracks or parts dislocation.	Acceleration of 490m/s <sup>2</sup> , 11ms duration, sine half-wave, 3 cycles in each of the 3 axis
6. Humidity	Contact resistance : 20mΩ max., Insulation resistance : 500MΩ min. No damage, cracks or parts dislocation.	96 hours at 40 ±2°C, and humidity of 90 to 95%
7. Temperature cycle	Contact resistance : 20mΩ max., Insulation resistance : 500MΩ min. No damage, cracks or parts dislocation.	-55°C → 5 to 35°C → 85°C → 5 to 35°C Times : 30 min. → 2 min. → 3 min. → 30 min. → 2 min. to 3 min. 5 cycles
8. Durability	Contact resistance : 20mΩ max., No damage, cracks or parts dislocation.	30 cycles
9. Resistance to soldering heat	No deformation of components affecting performance	Reflow : At the recommended temperature profile Manual soldering : 350°C for 3 seconds

Note 1 : This is the maximum current rating while all pins are powered or used as all power lines. When isolating power lines into multiple circuits, current ratings may go above the stated current ratings. Please consult Hirose for specific details before doing this.

Note 2 : Includes the temperature rise of power lines.

Note 3 : The connector should be completely dry. (no condensation present)

Note 4 : The term "storage" refers to the long-term storage condition of unused products before PCB mounting. The operating temperature and humidity ranges are applied while in a non-energized state, while in transport or after PCB mounting.

Note 5 : Information contained in this catalog represents general requirements for this Series.

Please contact us for the drawings and specifications for a specific part number shown.

## Material / Finish

Item	Component	Material	Finish	UL Flammability rating	RoHS2
Header	Insulator	LCP	Black	UL94V-0	YES
			Beige		
	Contact	Brass	Tin plating or gold plating	—	YES
Crimp socket	Insulator	PBT	White	UL94V-0	YES
			Black		
		LCP	Beige		
			Black		
Crimp contacts	Contact	Phosphor bronze	Tin plating or gold plating	—	YES

## Product Number Structure

Refer to the chart below when determining the product specifications from the product number.  
Please select from the product numbers listed in this catalog when placing orders.

### Header

**DF** **57** **H** - **\*** **P** - **1.2** **V**

①    ②    ③    ④    ⑤    ⑥    ⑦

① Series name : DF	⑤ Connector type P : Plug
② Series No. : 57	⑥ Contact pitch : 1.2mm
③ Insert guide key H : Yes	⑦ Termination section V : Straight SMT
④ Number of contacts : 2, 3, 4, 5, 6	

**DF** **57** **H** - **2** **P** - **2.4** **V**

④    ⑥

④ Number of contacts : 2	⑥ Contact pitch : 2.4mm (Middle pin of 3 pos. is removed, and rated voltage is 100 V)
--------------------------	--

### Socket

**DF** **57** **H** - **\*** **S** - **1.2** **C**

①    ②    ③    ④    ⑤    ⑥    ⑦    ⑧

① Series name : DF	⑤ Number of contacts : 2, 3, 4, 5, 6
② Series No. : 57	⑥ Connector type S : Crimp socket
③ Applicable wire size : Blank : 28 to 34 AWG	⑦ Contact pitch : 1.2mm
④ Insert guide key H : Yes	⑧ Termination section C : Crimp socket

**DF** **57** **A** **H** - **\*** **S** - **1.2** **C**

③    ⑤

③ Applicable wire size : A : 26 to 28 AWG	⑤ Number of contacts : 2, 4, 5, 6
--	-----------------------------------

### Crimp contact

**DF** **57** - **2830** **SCF** **A**

①    ②    ③

① Applicable wire size : 2628 : 26 to 28 AWG 2830 : 28 to 30 AWG 3234 : 32 to 34 AWG	② Packaging SCF : SCF : Female crimp contact / reel
	③ Plating type Blank : Tin plating A : Gold plating

Header(SMT)



Above image is 3 pos.

Recommended PCB layout (Thickness : 1.0mm)

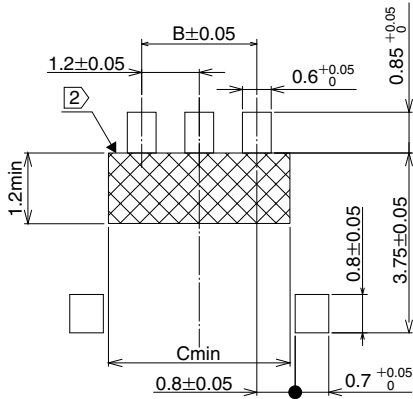

Recommended PCB layout (Thickness : 1.0mm)

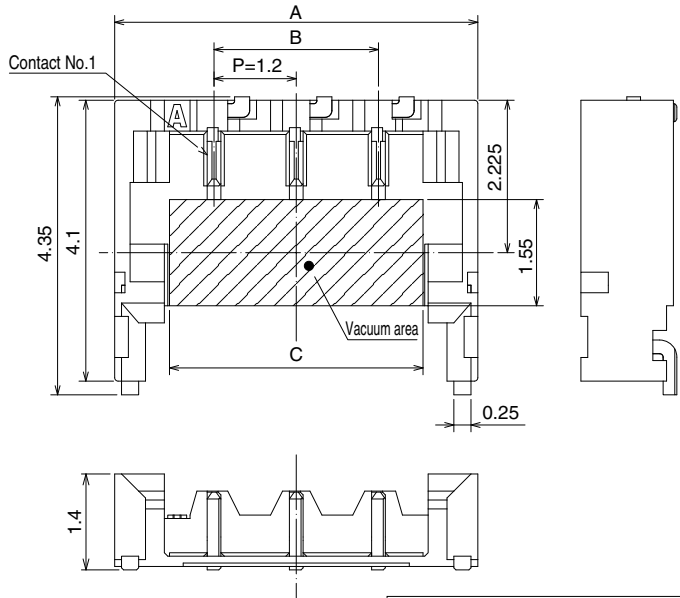
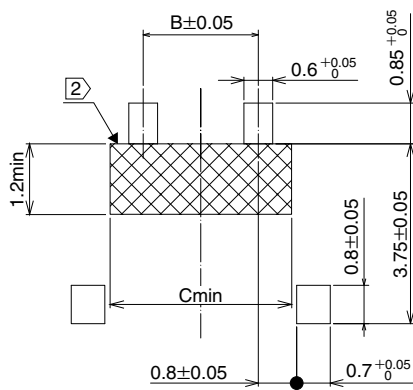

[Specification number] \*\*  
 (21) : Tin plated, color : black  
 (23) : Tin plated, color : beige  
 (51) : Gold plated, color : black

Unit : mm

Part No.	HRS No.	No. of Pos.	A	B	C	Specification No. (Note 3)		
						(21)	(23)	(51)
DF57H-2P-1.2V(**)	666-0104-7 **	2	4.1	1.2	2.5	✓	✓	✓
DF57H-3P-1.2V(**)	666-0105-0 **	3	5.3	2.4	3.7	✓	✓	✓
DF57H-4P-1.2V(**)	666-0106-2 **	4	6.5	3.6	4.9	✓	✓	✓
DF57H-5P-1.2V(**)	666-0107-5 **	5	7.7	4.8	6.1	✓	✓	✓
DF57H-6P-1.2V(**)	666-0108-8 **	6	8.9	6.0	7.3	✓	✓	✓

Note 1 : Embossed tape reel packaging (5,000 pcs/reel).

Note 2 : The cross-hatched area is a no conductive trace area.

Note 3 : For items whose specification number is blank, please contact a Hirose sales representative.

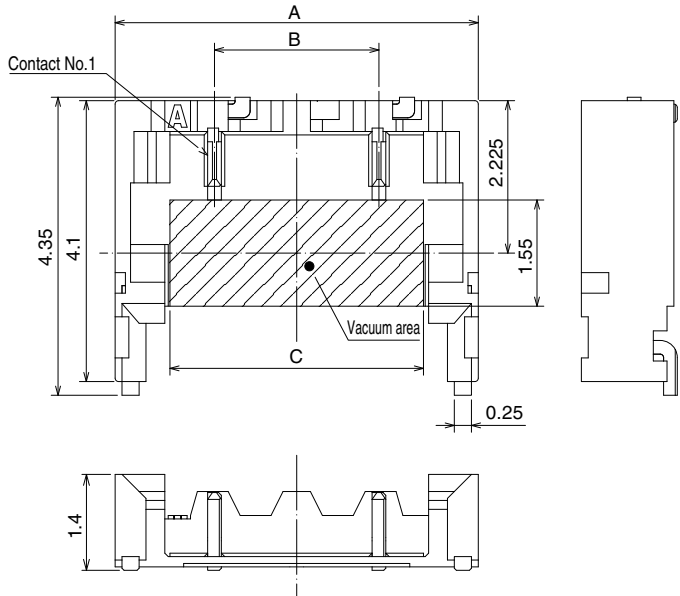

[Specification number] \*\*  
 (21) : Tin plated, color : black  
 (23) : Tin plated, color : beige

Unit : mm

Part No.	HRS No.	No. of Pos.	A	B	C	Specification No.	
						(21)	(23)
DF57H-2P-2.4V(**)	666-0109-0 **	2	5.4	2.4	3.7	✓	✓

●Packaging Specification

DF57H-2P-1.2V(\*\*)  
 DF57H-3P-1.2V(\*\*)  
 DF57H-2P-2.4V(\*\*)

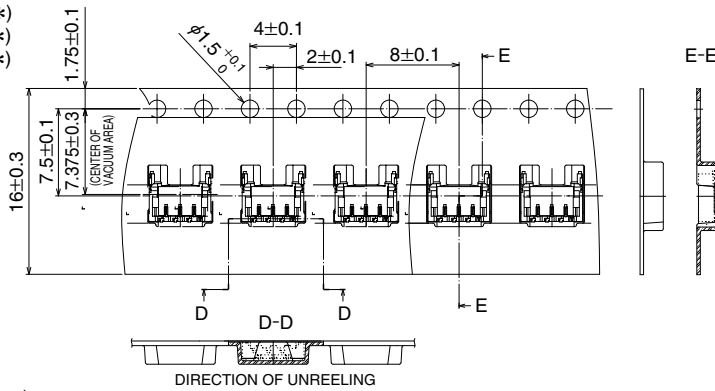

DF57H-4P-1.2V(\*\*)  
 DF57H-5P-1.2V(\*\*)  
 DF57H-6P-1.2V(\*\*)

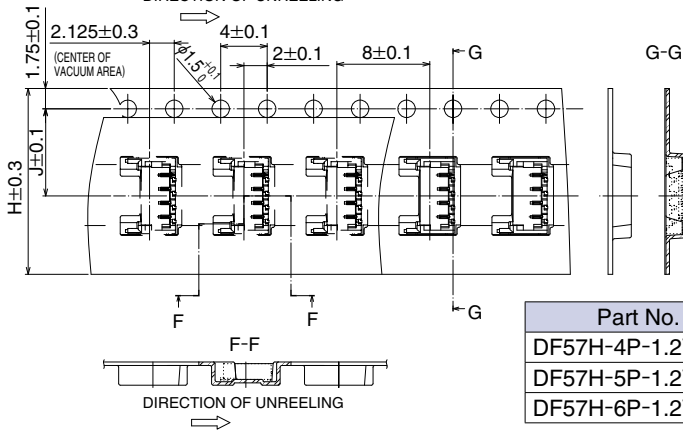

Unit : mm

Part No.	No. of contacts	H	J
DF57H-4P-1.2V(**)	4	16	7.5
DF57H-5P-1.2V(**)	5	16	7.5
DF57H-6P-1.2V(**)	6	24	11.5

■Crimp socket

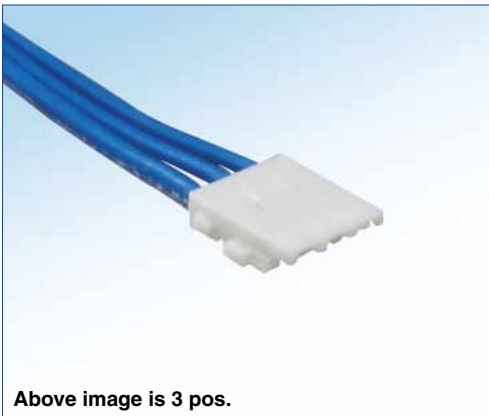

Above image is 3 pos.

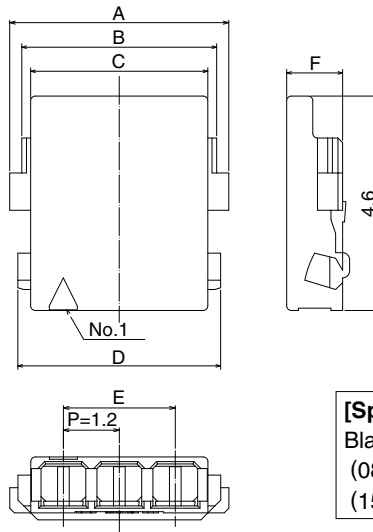

**[Specification number] \*\***  
 Blank : Material : PBT, color : white  
 (08) : Material : LCP, color : beige  
 (15) : Material : LCP, color : black

Unit : mm

Part No.	HRS No.	No. of contacts	A	B	C	D	E	F	Specification No.		
									Blank	(08)	(15)
DF57H-2S-1.2C(**)	666-0100-6 **	2	3.5	2.98	2.6	3.2	1.2	1.2	✓	✓	✓
DF57H-3S-1.2C(**)	666-0012-0 **	3	4.7	4.18	3.8	4.4	2.4	1.2	✓	✓	✓
DF57H-4S-1.2C(**)	666-0101-9 **	4	5.9	5.38	5.0	5.6	3.6	1.2	✓	✓	✓
DF57H-5S-1.2C(**)	666-0102-1 **	5	7.1	6.58	6.2	6.8	4.8	1.2	✓	✓	✓
DF57H-6S-1.2C(**)	666-0103-4 **	6	8.3	7.78	7.4	8.0	6.0	1.2	✓	✓	✓

Note 1 : The quantity is delivered per pack (1,000 pcs.). Order by number of pack.

■Socket for 26 AWG

Unit : mm

Part No.	HRS No.	No. of contacts	A	B	C	D	E	F	Specification No. (Note 2)		
									Blank	(10)	(15)
DF57AH-2S-1.2C(**)	666-0112-0 **	2	3.5	2.98	2.6	3.2	1.2	1.4	✓		✓
DF57AH-4S-1.2C(**)	666-0113-0 **	4	5.9	5.4	5.0	5.6	3.6	1.4	✓		
DF57AH-5S-1.2C(**)	666-0110-0 **	5	7.1	6.6	6.2	6.8	4.8	1.4	✓	✓	
DF57AH-6S-1.2C(**)	666-0111-2 **	6	8.3	7.8	7.4	8.0	6.0	1.4	✓	✓	

Note 1 : The quantity is delivered per pack (1,000 pcs.). Order by number of pack.

Note 2 : For items whose specification number is blank, please contact a Hirose sales representative.

**[Specification number] \*\***  
 Blank : Material : PBT, color : black  
 (10) : Material : PBT, color : white  
 (15) : Material : LCP, color : black

## ■ Crimp contact

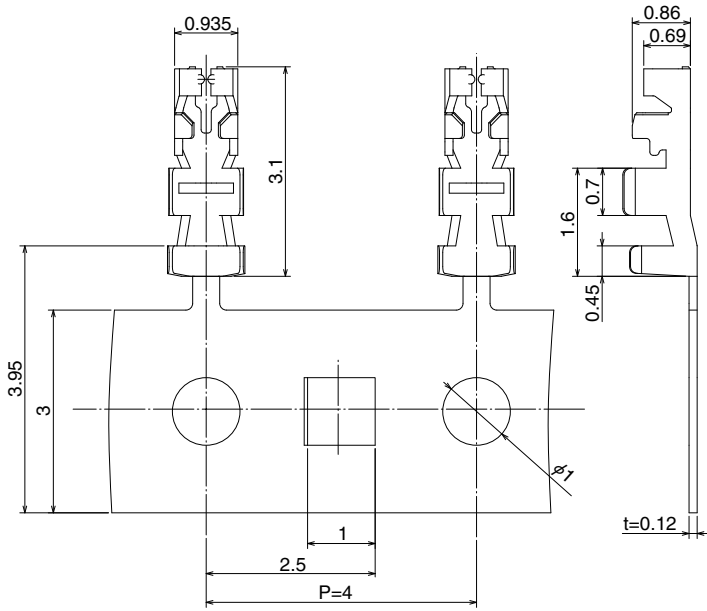

**[Packaging Specification]**  
 Blank : Embossed tape packaging (40,000 pcs/reel)  
 (41) : Embossed tape packaging (35,000 pcs/reel)

Part No.	HRS No.	Packaging	Quantity	Finish	Applicable wire	Applicable socket connector
DF57-2628SCF(41)	666-0013-3 41	Reel	35,000	Tin plated	26 to 28 AWG	DF57AH-*S-1.2C(**)
DF57-2628SCFA(41)	666-0033-0 41	Reel	35,000	Gold plated		
DF57-2830SCF	666-0001-4	Reel	40,000	Tin plated	28 to 30 AWG	DF57H-*S-1.2C(**)
DF57-2830SCFA	666-0034-3	Reel	40,000	Gold plated		
DF57-3234SCF	666-0016-1	Reel	40,000	Tin plated	32 to 34 AWG	

Note : Embossed tape reel packaging (40,000 pcs/reel).  
 Order by number of reels.

### ● Applicable wire (Tin plated annealed copper wire)

Part No.	Wire size (Stranded wire conductor)	Jacket outer diameter	Recommended cable
DF57-2628SCF(41)	26 AWG (7/φ0.16mm)	φ0.88mm max.	UL3610
DF57-2628SCFA	28 AWG (7/φ0.127mm)		UL1061
DF57-2830SCF	28 AWG (7/φ0.127mm)	φ0.5mm – φ0.63mm	UL1571 (Thin wire), UL10584 (ETFE wire)
DF57-2830SCFA	30 AWG (7/φ0.102mm)		
DF57-3234SCF	32 AWG (7/φ0.08mm)	φ0.32mm – φ0.54mm	UL1571
	34 AWG (Note 2)		—

● Strip length 1.0 to 1.4mm

Note 1 : When using other than the recommended wire, please contact a Hirose sales representative.  
 Note 2 : When using 34 AWG wire, please contact a Hirose sales representative.

## ◆ Tools

Type	Part No.	HRS No.	Applicable contact
Applicator	AP105-DF57-2628S	901-4622-2	DF57-2628SCF(41)
			DF57-2628SCFA(41)
	AP105-DF57-2830S	901-4618-5	DF57-2830SCF
	AP105-DF57-2830SA	901-4645-0	DF57-2830SCFA
	AP105-DF57-3234S	901-4629-1	DF57-3234SCF
Press	CM-105C	901-0001-0	—
Hand crimping tool	HT305/DF57-2830HC(Note 2)	902-4635-0	DF57-2830SCF
Contact extraction tool	DF-C-PO(B)	550-0179-2	DF57-****SCF(A)

Note 1 : Please conduct crimping work according to the table in the Crimp Quality Standard (ETAD-H0404-00).  
 Note 2 : The compatible wire is limited to UL1571 of thin wire type, 28 to 30 AWG when you use the Hand crimping tool.  
 Note 3 : Problems with tools other than those specified by Hirose are outside the scope of warranty.  
 Note 4 : When non-authorized tools are used, please consult with Hirose sales representative about provision of the drawing of the crimping tool.



## ◆ Crimping Precautions

### ■ Items required prior to start crimping

The work-related documents shown below are required before starting the harness connections.  
(The ● mark shows the document required.)

When the documents shown below are not available, ask our sales personnel to provide them.

Document Title	Description	Automatic Crimping Machine	Hand Crimping Tool	Remarks
(1) Main unit of crimping machine instruction manual	Explanation of main press machine unit	●	—	When purchasing main press machine unit, it is bundled.
(2) Operating Instructions for Hand Tool	Crimp operation	●	—	When purchasing Applicator, it is bundled.
(3) Applicator Spare Parts Identification	Explanation for Applicator installation	●	—	
(4) Crimp Conditions	Standard values of : Crimp height ; Tensile strength	●	—	
(5) Crimp Quality Standards	Various standards for crimping conditions	●	—	
(6) Operating Instructions for Hand Tool	Inspection items of : Crimp height ; Crimp operation Tensile strength	—	●	When purchasing Hand Tool, it is bundled.
(7) Cable Assembly Procedure	Cable Assembly Procedure	●	●	Ask our sales personal to provide them.

### ■ Tools

When crimping work is applied to our contacts, the tool designated by Hirose should be used.  
Crimping work by using tools other than as designated must not be done because it may result in contact failure, disconnection of cable, etc.

\*The operating instructions manual is available for the crimping machine and the applicator.

Be sure to carefully read the operating instructions manual before implementing the work.

### ■ Applicable electric wires

Check that the electric wire to be used is in the range of application.

If you intend to use an electric wire other than the recommended one, ask our sales personnel.

#### [Precautions]

- Electric wires that are applicable for crimping connectors shall, principally, be the tin-plated stranded soft-copper wire.
- Crimping of electric wires wherein single wires, polyester yarns, etc., exist and crimping of tin-coated wires should be avoided.
- Avoid crimping two electric wires together.
- The setting values of crimp height (Note 1) may vary between tin-plated and gold-plated terminals even if the same electric wires are used.
- The setting values of crimp height (Note 1) may vary depending on the difference in the core wire configuration even if the computed cross-sectional area is the same.

Note 1 : The crimp height is an important item that determines crimping quality. We execute crimping tests for each electric wire to ensure the optimal value for the crimp height with high precision, thereby ensuring optimal setup values.

## Handling Points

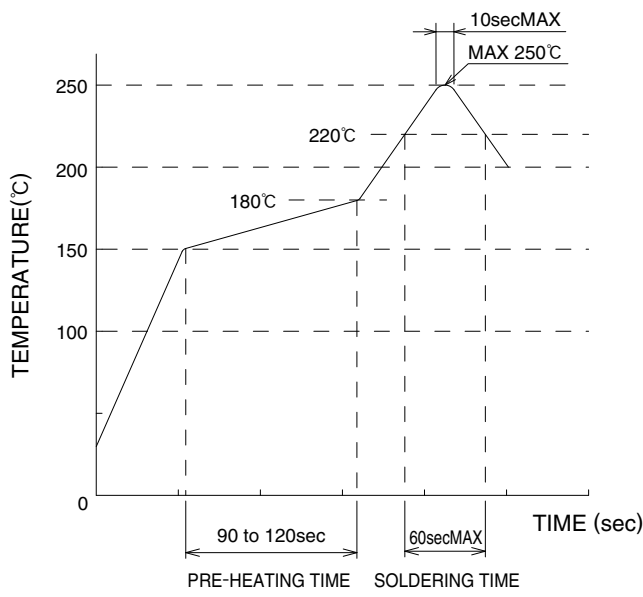
<p>1.Recommended temperature profile</p>	 <p>The temperature profiles are based on the above conditions. In individual applications the actual temperature may vary, depending on solder paste type, volume/ thickness and board size/thickness. Consult your solder paste and equipment manufacturer for specific recommendations.</p>
<p>2.Recommended manual soldering</p>	<p>Manual soldering : 350°C ± 10°C for 3 seconds</p>
<p>3.Recommended screen thickness and open area ratio (Pattern area ratio)</p>	<p>Thickness : 0.1mm Open area ratio : 100%</p>
<p>4.Board warpage</p>	<p>Maximum of 0.02mm at the connector center, with both ends of the connector as reference points.</p>
<p>5.Cleaning conditions</p>	<p>Cleaning is not recommended. When cleaning, please evaluate as if can deteriorate the performance including mechanical operation and environmental resistance.</p>
<p>6.Precautions</p>	<ul style="list-style-type: none"> <li>■When inserting crimp-type (solderless) terminals to crimping (solderless) sockets, to maintain reliable performance, please do not insert obliquely.</li> <li>■DO NOT mate/un-mate non-terminated plugs with non-mounted receptacles. This may lead to damage or deformation of the contacts.</li> <li>■Removal of the holding electric cable may cause damage so please be careful.</li> <li>■DO NOT apply flux to the contact terminals when hand soldering the receptacle to the board. Wicking of the flux into the electrical contact areas may lead to connection failures.</li> <li>■Slight discoloration on the insulating materials will not affect form, fit or function of the connectors. Black spots may appear on the mold resin but this does not affect the product quality.</li> <li>■Please refer to the documents "DF57 Series Cable assembly Procedure ETAD-H0421", "Crimp condition" and "DF57-***SCF(A)** Crimp quality standards ATAD-H0404" for the cable assembly procedures.</li> <li>■Please refer to the "DF57H Series Mating/Unmating Operation Instruction Manual (ETAD-H0652)" for the connector operation.</li> </ul>
<p>7.Handling procedure</p>	<p>Please refer to the following documents.</p> <ul style="list-style-type: none"> <li>■Crimp Quality Standard (ETAD-H0404-00)</li> <li>■Cable Assembly Procedure (ETAD-H0421-00)</li> <li>■Mating/Unmating Operation Instruction Manual (ETAD-H0652-00)</li> <li>■Procedures for Using the Crimp Terminal Extracting Tool (ETAD-H0249-00)</li> <li>■Board-to-Wire Connector Guidelines (ETAD-H1023-00)</li> </ul>

Apr. 1. 2024 Copyright 2024 HIROSE ELECTRIC CO., LTD. All Rights Reserved.



8. Insertion and removal operation method

**Mating**

- ① Determine position, fitting the external form
- ② Insert the cable side
- ③ Push the contact portion side

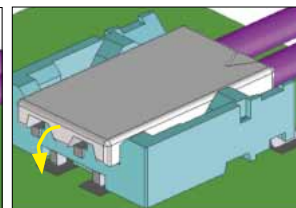
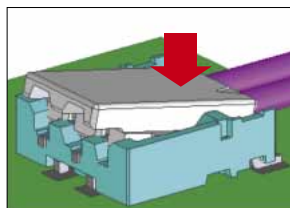
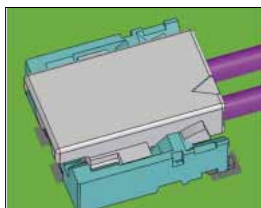

**Un-mating**

- ① Engage lever
- ② Pull up and release the simple lock
- ③ The reinforced lock is also released and the un-mating is complete

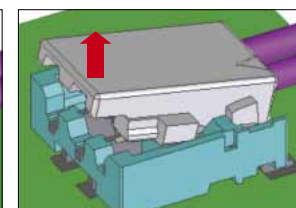
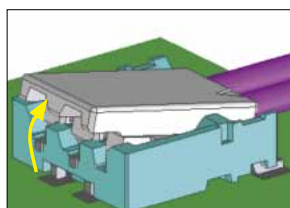

9. Mating compatibility

		DF57H		DF57	
Header					
Socket					
Mating compatibility		Y	Y	N	Y
Additional guiding keys		Y	N	-	N

**HIROSE ELECTRIC CO.,LTD.**

2-6-3,Nakagawa Chuoh,Tsuzuki-Ku,Yokohama-Shi 224-8540,JAPAN  
<https://www.hirose.com/>