

DF59 Series



■ Features

● Common to all series

1. High Operating Temperature

DF59's are rated at temperatures up to 105 °C.

● DF59

2. Swing Lock Structure (Wire-to-Board)

The DF59 features a "swing-lock" mechanism that employs both a positive and friction lock. This helps to prevent accidental unmating by severe wiring and mechanical stress.

3. Short-Circuit Pin

The Short-Circuit Pin allows the termination of an open circuit. Typically used at the end of a series of connected circuit boards.

4. Multi Function Design

The DF59 has the ability to function as either a Board-to-Wire or Board-to-Board System. The PCB mounted receptacle is designed to mate with the W-to-B, B-to-B, and Short Circuit Pin connectors. This multi function ability allows versatility while keeping connectors to a minimum.

5. Contact Design

The terminal design features two-point contact to ensure a highly reliable connection.

6. Common Applicator

Crimping can be performed using the applicator (AP105-DF11-22S) for the existing series DF11-22S C F(A), by replacing the die with the one for DF59 series.

* For crimping quality standards and crimping conditions, crimping needs to be performed in accordance with the specific conditions of DF59-22PCFA.

● Common to DF59/59S

7. Floating Structure (Board-to-Board)

The Board-to-Board connector can be used to connect two PCB together in a co-planar arrangement and features a "Stress free contact" that floats $\pm 0.5\text{mm}$ in the X, Y and Z dimensions.

8. Space Savings

The DF59 series offers high performance in a compact, space saving design; featuring a 2mm pitch and coupled with a mated height of only 2.48mm with AWG#22 cable. The single position floating plug DF59S is specifically designed to save space, and can be mounted in high density applications.

9. Robust locking structure on DF59M (W-to-B Connection)

The lock mechanism on compact DF59M provides 16N horizontal lock strength. (Fig.4)

10. Standardization of PCB layout

The DF59S type is used on board-to-board connections, and the DF59M type is intended for wire-to-board connections. Although they have different receptacles, the PCB mounting pattern can be used for these two types. Different combinations of these connectors can be used in the same system with a common PCB. This allows for standardization of PCB. (Fig.5)

Note : Each stencil mask is necessary

DF59 floating amount $\pm 0.5\text{mm}$ (X, Y, Z directions)

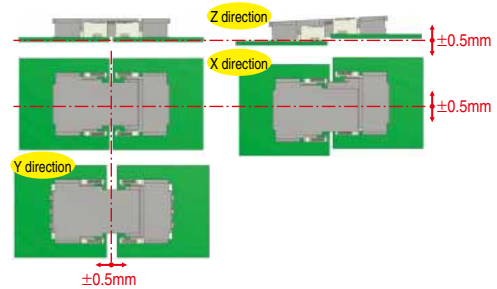

DF59S floating amount

$\pm 0.5\text{mm}$ (X, Y direction), $\pm 0.2\text{mm}$ (Z direction)

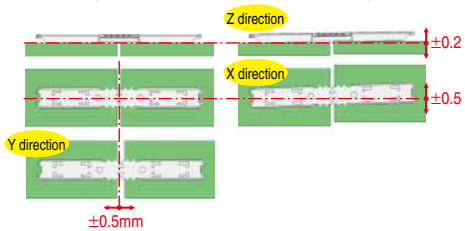

Fig.1

◆ Swing-Lock Structure (Board-to-Wire Type)

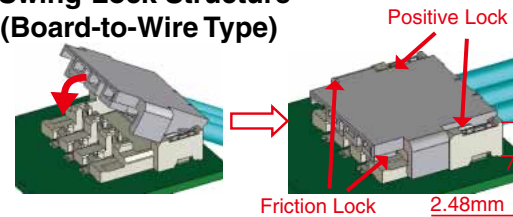

Fig.2

◆ Short-Circuit Pin

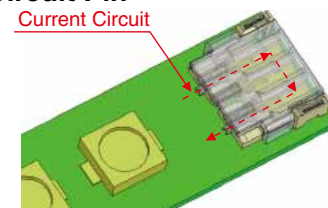

Fig.3

◆ W-to-B structure (DF59M)

Clear tactile click and high locking strength achieved by the robust locking mechanism
Mating force : 16N min. (in a horizontal direction)



Fig.4

◆ Standardization of PCB pattern

DF59S type and DF59M type can be used in the same system by using a common PCB.



Fig.5

Product Specifications

Ratings	Current rating	DF59/S	3A	Operating Temperature : -40 to 105°C (Note 1) Operating Humidity Range : 20 to 80%
		DF59M	6A (22 AWG), 5A (24 AWG) 4A (26 AWG), 3A (28 AWG)	
	Voltage rating	DF59/S	AC/DC 230V (Note 3)	Storage Temperature Range : -10 to 60°C (Note 2) Storage Humidity Range : 40 to 70% (Note 2)
		DF59M	AC/DC 300V (Note 3)	

Items	Specifications		Conditions
1.Contact resistance	DF59-*P-2FC/SP DF59S	50mΩ min.	Under 6V DC, must be measured by 100mA (DC or 1000Hz)
	DF59M-1S-H	45mΩ min.	
	DF59-*P-2C	30mΩ min.	
2.Vibration	No electrical discontinuity over 1μs.		Frequency 10 to 55Hz, single amplitude 0.75mm, 3 directions, 10 cycles each
3.Shock	No electrical discontinuity over 1μs.		Acceleration 490 m/s ² , 11ms; duration, sine half-wave 3 cycles in each of the 3 axis.
4.Humidity		■Contact resistance	Temperature 40 ± 2°C, humidity 90 to 95%, left for 96 hours
	DF59-*P-2FC/SP DF59S	50mΩ min.	
	DF59M	45mΩ min.	
	DF59-*P-2C	30mΩ min.	
5.Temperature cycle		■Contact resistance	(-55°C : 30 min. → 5-35°C : 2 to 3 min. → 85°C : 30 min. → 5-35°C : 2 to 3 min.) 5 cycles
	DF59-*P-2FC/SP DF59S	50mΩ min.	
	DF59M	45mΩ min.	
	DF59-*P-2C	30mΩ min.	
6. Operating Life		■Contact resistance	■Number of insertion and withdrawal force
	DF59-*P-2FC		30 times
	DF59-*P-2FC/SP DF59S	50mΩ min.	10 times
	DF59M	45mΩ min.	20 times
	DF59-*P-2C	30mΩ min.	30 times
7.Resistance to soldering heat	No melting of resin which affect the performance.		Reflow : Depends on recommended temperature profile. Hand soldering : Soldering iron temperature 350 ± 10°C, 3 sec.

Note 1 : Including temperature rise caused by current flow.

Note 2 : The term "storage" refers to products stored for long period of time prior to mounting and use.

Operating temperature and humidity range covers connectors after installation, storage, shipment or during transportation.

Note 3 : The rated voltage is the applied voltage when connectors are mounted parallel to each other on the PCB with a distance of 1.6mm or more between them. Hirose recommends his mounting distance.

This mounting distance is required in order to prevent creepage between the printed wiring to maintain an effective voltage of 300V, according to IEC 60664 and JIS C 60664 standards.

Materials / Finish

Items	Parts	Materials	Treatment	UL Specification
Receptacle	DF59	Insulator	LCP	Natural UL94V-0
	DF59S DF59M	Contact	Phosphor bronze	Gold plated
			Copper Alloy	Tin plated
Floating plug	DF59	Insulator	PBT	White UL94V-0
		Contact	Brass	Gold plated
	DF59S	Insulator	LCP	Natural UL94V-0
		Contact	Brass	Tin plated
Crimp contact	DF59M	Contact	Copper Alloy	Tin plated
Short pin	Insulator	PBT	White UL94V-0	
		Brass	Gold plated	
Crimp case	Insulator	PBT	White UL94V-0	
Crimp contact	Contact	Phosphor bronze	Gold plated	

Product Number Structure

Refer to the chart below when determining the product specifications from the product number.
Please select from the product numbers listed in this catalog when placing orders.

●Receptacle

DF 59 # - * S - * V
 ① ② ③ ④ ⑤ ⑥ ⑦

① Series Name : DF	⑥ Pitch None : Single contact type 2 : Standard 2mm (4mm : Without the central contact)
② Series No. : 59	
③ None : Standard S : B-to-B type M : W-to-B type	⑦ Termination form V : SMT straight type (B-to-B type) H : SMT right angle type (W-to-B type)
④ Number of contacts : 1, 2, 3, 4	
⑤ Type of connector S : Receptacle	

●Plug

DF 59 # - * P - * FC
 ① ② ③ ④ ⑤ ⑥ ⑦

① Series Name : DF	⑤ Type of connector P : Plug
② Series No. : 59	
③ None : Standard S : Single contact type	⑥ Pitch 2 : DF59 : 2mm (4mm : Without the central contact) None : DF59S/M
④ Number of contacts DF59 : 2, 3, 4 DF59S : 1	
	⑦ Termination form FC : Floating

●Short-Circuit pin

DF 59 - * P - 2 SP
 ① ② ③ ④ ⑤ ⑥

① Series Name : DF	⑤ Pitch : 2mm
② Series No. : 59	
③ Number of contacts : 2, 3, 4	⑥ Termination form SP : Short Pin
④ Type of connector P : Plug	

●Crimp Socket

DF 59 - * P - 2 C
 ① ② ③ ④ ⑤ ⑥

① Series Name : DF	⑤ Pitch : 2mm
② Series No. : 59	
③ Number of contacts : 2, 3, 4	⑥ Termination form C : Crimp case
④ Type of connector P : Plug	

●Contact (W-to-B)

DF 59 M - 2224 PCF
 ① ② ③ ④ ⑤

① Series Name : DF	⑤ Form Type/Package Type/Plating type PCFA : Plug crimping contact-Reel contact-Gold plating PCA : Plug crimping contact-Bulk contact-Gold plating PCF : Plug crimping contact-Reel contact-Tin plating PC : Plug crimping contact-Bulk contact-Tin plating
② Series No. : 59	
③ None : Standard M : Single contact type (W-to-B M=micro)	
④ Applicable Wire 22 : 22 AWG 2224 : 22 to 24 AWG 2628 : 26 to 28 AWG	

■ Straight Receptacle (SMT)

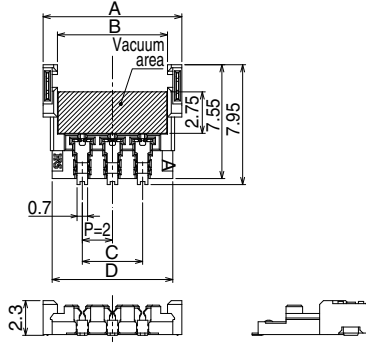

● Recommended PCB Dimensions (t=1.6mm)

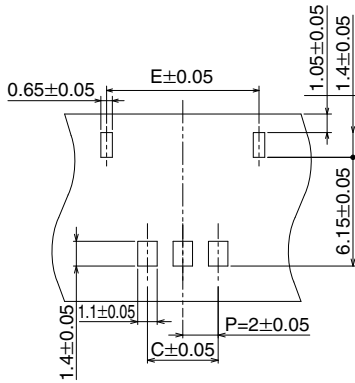

● Packaging Dimensions

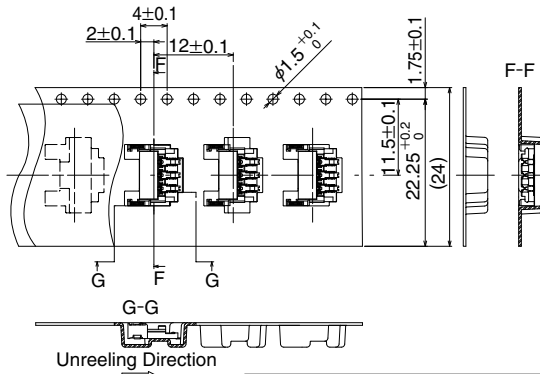

[Specification No.]
(51) : Gold plating, emboss packaging

Unit : mm

Part No.	HRS No.	No. of contacts	A	B	C	D	E
DF59-2S-2V(51)	667-0001-0 51	2	7.2	5.3	2.0	6.0	6.62
DF59-3S-2V(51)	667-0002-3 51	3	9.2	7.3	4.0	8.0	8.62
DF59-4S-2V(51)	667-0003-6 51	4	11.2	9.3	6.0	10.0	10.62
DF59-2S-4V(51)	667-0021-8 51	2*	9.2	7.3	4.0	8.0	8.62

* DF59-2S-4V(51) is made by removing the middle pin of DF59-3S-2V(51) at the factory.

Note : Please order in full reel quantities. (2,000 pcs/reel)

■ Floating Plug

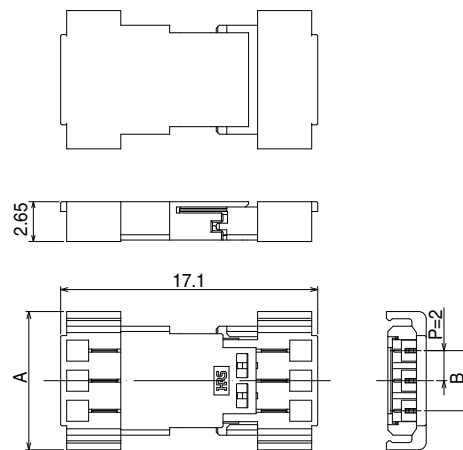
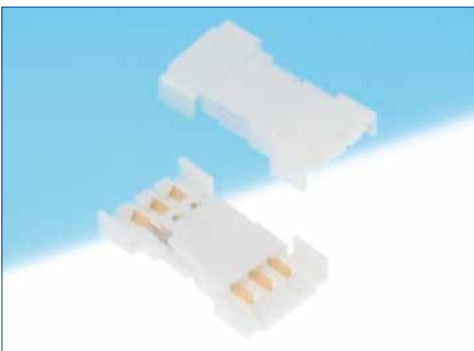

[Specification No.]
(50) : Gold plating, tray packaging

Unit : mm

Part No.	HRS No.	No. of contacts	A	B	Packaged Quantity/Tray
DF59-2P-2FC(50)	667-0006-4 50	2	7.2	2.0	50
DF59-3P-2FC(50)	667-0007-7 50	3	9.2	4.0	
DF59-4P-2FC(50)	667-0008-0 50	4	11.2	6.0	
DF59-2P-4FC(50)	667-0020-5 50	2*	9.2	4.0	

* DF59-2P-4FC(50) is made by removing the middle pin of DF59-3P-2FC(50) at the factory.

Note : Please order in full tray quantities. (50 pcs/tray)

Short-Circuit Pin

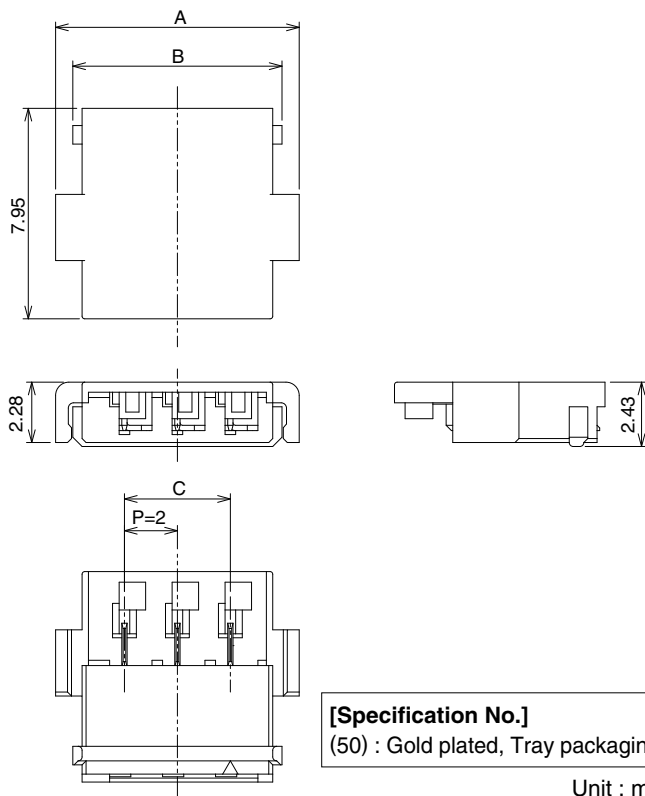

[Specification No.]
(50) : Gold plated, Tray packaging

Unit : mm

Part No.	HRS No.	No. of contacts	A	B	C	Packaged Quantity/Tray
DF59-2P-2SP(50)	667-0017-0 50	2	7.2	5.9	2.0	100
DF59-3P-2SP(50)	667-0018-3 50	3	9.2	7.9	4.0	
DF59-4P-2SP(50)	667-0046-9 50	4	11.2	9.9	6.0	

Note 1 : Please order in full tray quantities.

Note 2 : For 4 pos. type contact No.1 and 2, No.3 and 4 are connected respectively.

Crimp Socket

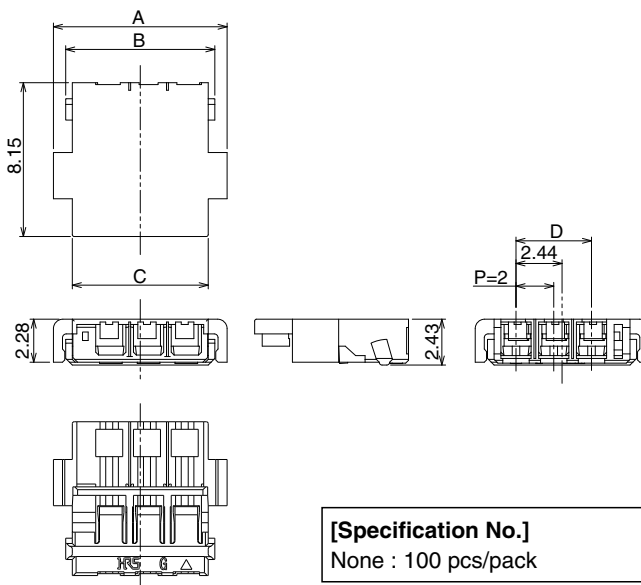
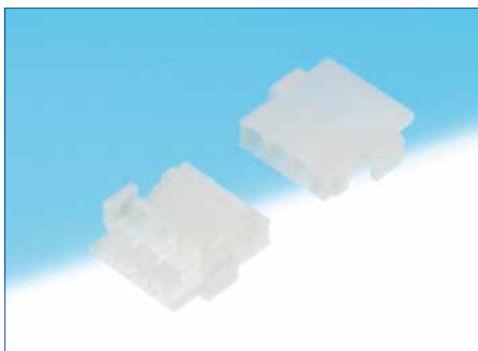

[Specification No.]
None : 100 pcs/pack

Unit : mm

Part No.	HRS No.	No. of contacts	A	B	C	D
DF59-2P-2C	667-0011-4 00	2	7.2	5.9	5.2	2.0
DF59-3P-2C	667-0012-7 00	3	9.2	7.9	7.2	4.0
DF59-4P-2C	667-0013-0 00	4	11.2	9.9	9.2	6.0

Note : Please order in full pack quantities. (100 pcs/pack)

■ Crimp contact

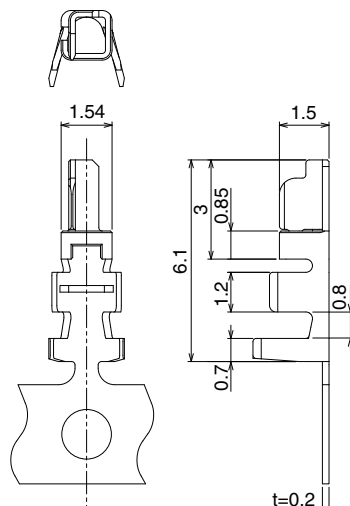

Part No.	HRS No.	Packaging	Quantity	Treatment
DF59-22PCFA	667-0016-8 00	Reel contact (Note 1)	10,000 contacts / reel	Gold plated
DF59-22PCA	667-0022-0 00	Bulk contact (Note 2)	100 contacts / pack	

Note 1 : Please order reel contacts by full reel quantities. (10,000 pcs/reel)

Note 2 : Please order loose piece contacts in full pack. (100 pcs/pack)

● Applicable Wire (Tin plated soft copper wire)

Conductor Size (Wire Constitution)	Jacket Diameter
22 AWG (17 / ϕ 0.16mm)	UL1061 (ϕ 1.26mm)
	UL3265 (ϕ 1.38mm)

● Recommended Wire

UL1061, UL3265

● Strip Length

1.7 to 2.3mm

Note 1 : For applicable cable other than those listed above, refer to Crimp Condition Table. Crimp Condition Table is available on product web page.

(If you are using a cable that is not listed in Crimp Condition Table or for LED application usage, please contact a Hirose sales representative.)

Note 2 : The strip length is a reference value. Please make adjustments to match with dimensional specifications. Refer to the crimping quality standards (ETAD-H0504-00) for details.

Single Contact Type Straight Receptacle (SMT)

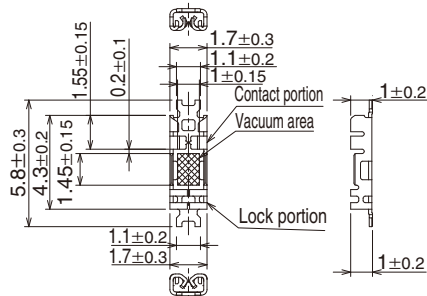

●Packaging Dimensions

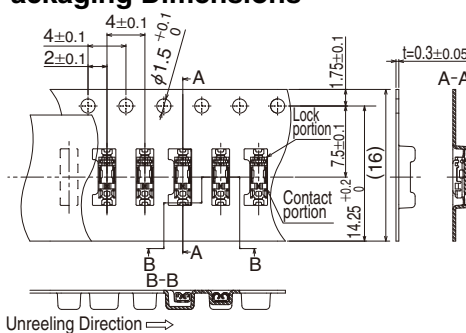

●Recommended PCB Dimensions (t=1.6mm)

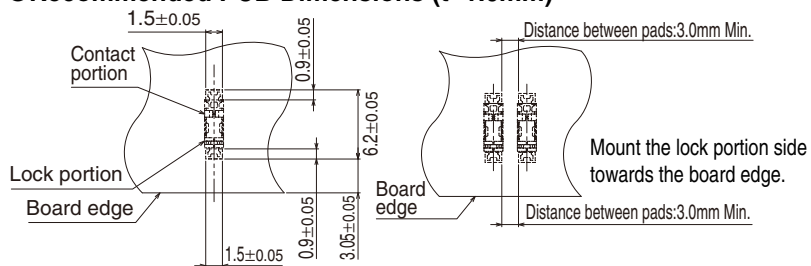

Part No.	HRS No.
DF59S-1S-V(21)	667-0024-6 21

[Specification No.]
(21) : Tin plating, emboss packaging

Note : Please order in full reel quantities. (10,000 pcs/reel)

Single Contact Type Floating Plug

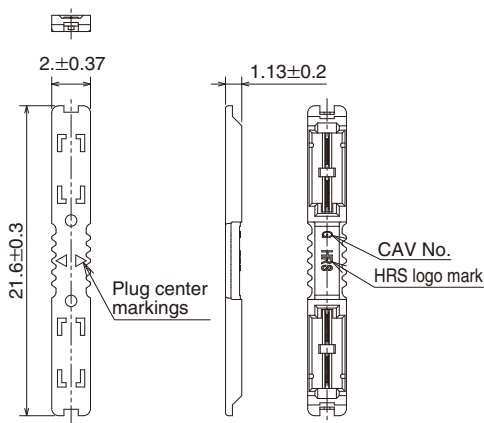

Part No.	HRS No.
DF59S-1P-FC(21)	667-0023-3 21

[Specification No.]
(21) : Tin plating, emboss packaging

Note : Please order in full reel quantities. (10,000 pcs/reel)

Single Contact Type Right Angle Receptacle (SMT)

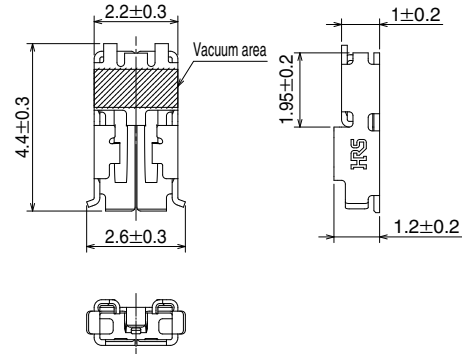
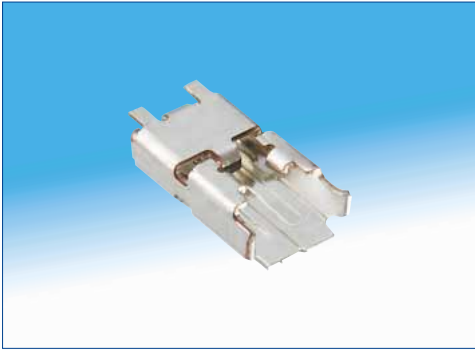

Recommended PCB Dimensions (t=1.6mm)

Packaging Dimensions

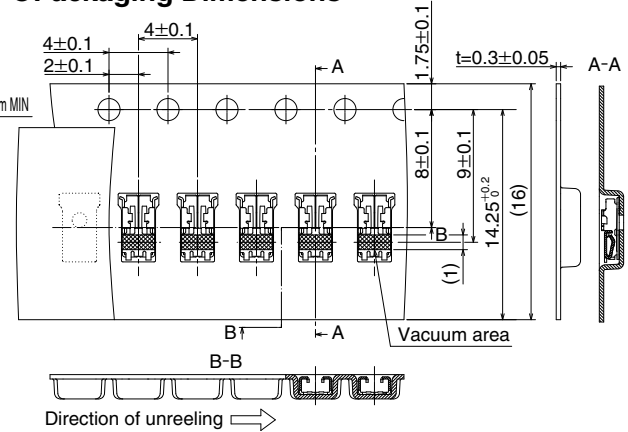
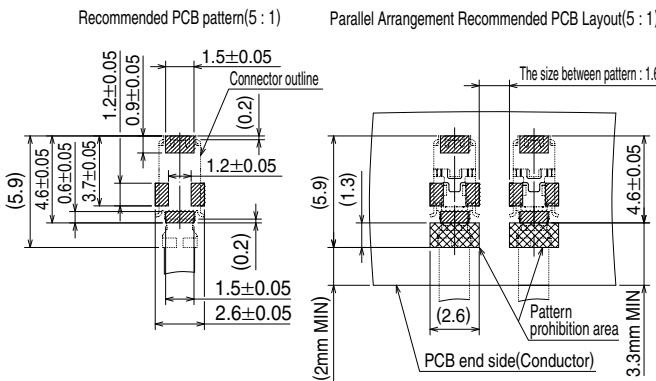

Part No.	HRS No.
DF59M-1S-H(21)	667-0041-5 21

[Specification No.]
(21) : Tin plating, emboss packaging

Note 1 : Please order in full reel quantities. (10,000 pcs/reel)

Note 2 : This connector is designed to mate with Crimp contact of DF59M only. (P.8)

Single Contact Type Crimp Contact

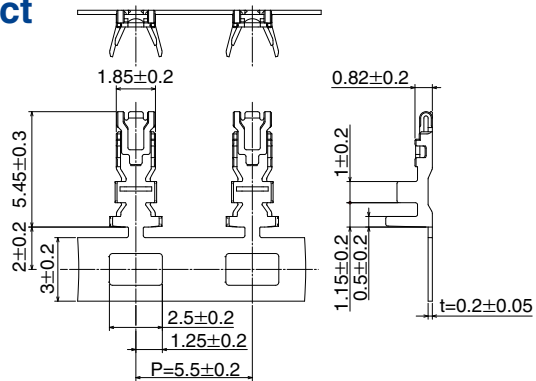
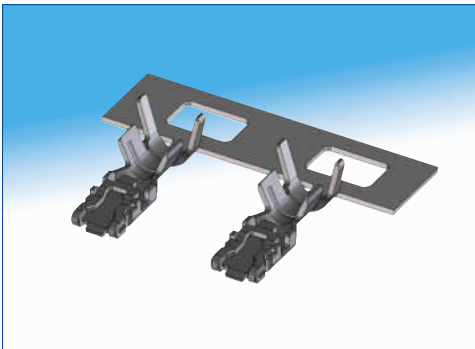

Part No.	HRS No.	Applicable Wire				By Type	Quantity	Treatment
		Recommended Wire	Jacket Diameter	Conductor Size	Wire Constitution			
DF59M-2224PCF	667-0042-8 00	UL10368	φ1.11 to 1.26mm	22 AWG	17/φ0.16mm	Reel contact (Note 1)	15,000/reel	Tin plated
DF59M-2224PC	667-0044-3 00			24 AWG	11/φ0.16mm	Bulk contact (Note 2)		
DF59M-2628PCF	667-0043-0 00		φ0.88 to 0.98mm	26 AWG	7/φ0.16mm	Reel contact (Note 1)	15,000/reel	
				28 AWG	7/φ0.17mm	Bulk contact (Note 2)		
DF59M-2628PC	667-0045-6 00		φ0.98mm	26 AWG	7/φ0.16mm	Bulk contact (Note 2)	100/pack	
				28 AWG	7/φ0.17mm			

Note 1 : Please order reel contacts by full reel quantities. (15,000 pcs/reel)

Note 2 : Please order loose piece contacts in full pack. (100 pcs/pack)

Note 3 : For applicable cable other than those listed above, refer to Crimp Condition Table. Crimp Condition Table is available on product web page.

(If you are using a cable that is not listed in Crimp Condition Table or for LED application usage, please contact a Hirose sales representative.)

Note 4 : The strip length is a reference value. Please make adjustments to match with dimensional specifications.

Refer to the crimping quality standards (ETAD-H0778-00) for details.

◆Applicable Crimping Tool

Types	Part No.	HRS No.	Applicable Contact	Remarks
Applicator	AP105-DF59-22P	901-4619-8	DF59-22PCFA	
	AP105-DF59M-2224P	901-4638-2	DF59M-2224PCF	(Note 2) Manufactured by Japan Automatic Machine Co., Ltd.
	DHS887200H-UP	—		
	AP105-DF59M-2628P	901-4639-5	DF59M-2628PCF	(Note 2) Manufactured by Japan Automatic Machine Co., Ltd.
	DHS887300H-UP	—		
Press Unit	CM-105C	901-0001-0	-	
Hand Tool	HT801/DF59-22P	550-0404-7	DF59-22PCA ※UL1061 AWG#22 Only	
	HT801/DF59M-2224P	550-0420-3	DF59M-2224PC ※UL10368 AWG#22, 24 Only	
	HT801/DF59M-2628P	550-0421-6	DF59M-2628PC ※UL10368 AWG#26, 28 Only	
Extraction Tool (W-to-B)	DF-C-PO(B)	550-0179-2	DF59-22PCFA DF59-22PCA	
	DF-C-PO(A)	550-0170-8	DF59M Series	

Note 1 : Customers are strongly encouraged to utilize HRS application tooling or tooling created by a Hirose tooling partner. Hirose assumes no liability for customers using tooling from non-recognized sources.

Note 2 : Please contact Japan Automatic Machine Co., Ltd. (hereinafter J.A.M.) through their website regarding crimping issues when using applicators manufactured by J.A.M. URL <http://www.jam-net.co.jp>

◆Mating Dimensions

●Board-to-board connection (floating plug)

[Standard]

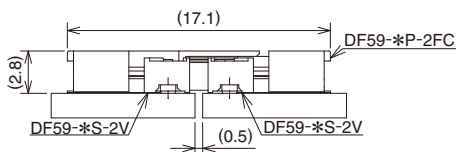

[Single contact type]

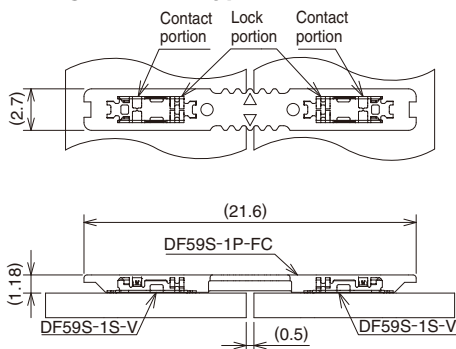

●Short-circuit pin connection

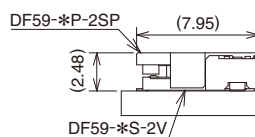

●Wire-to-Board connection

[Standard]

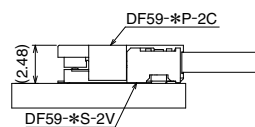

[Single contact type]

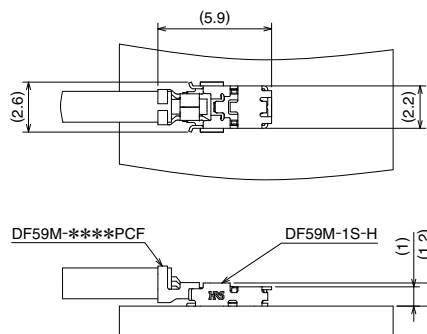

Operating Precautions

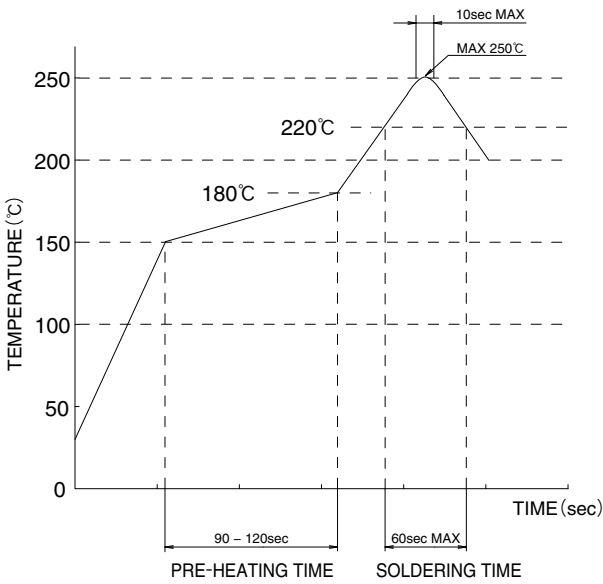
<p>1. Recommended Temperature Profile (Lead-free soldering possible)</p>	 <p>[Applicable Conditions]</p> <ol style="list-style-type: none"> 1. Peak Temperature : MAX 250°C 2. Heated Area : 220°C or above, within 60 sec. 3. Pre-heating Area : 150 to 180°C, 90 to 120 sec. 4. Number of Times : within 2 times <p>*Measured at contact lead area Please be noted that the reflow condition may vary depending on soldering paste type, manufacturer of soldering material, board size, as well as conditions of other mounting materials. (*1) Above temperature profile is our recommended value.</p>
<p>2. Recommended Hand Solder Conditions</p>	<p>Soldering iron temperature : 350 ± 10°C, soldering time : within 3 seconds</p>
<p>3. Recommended Screen Thickness, Open Ratio (Pattern Area Ratio)</p>	<p>Thickness 0.1mm, Open ratio : 100%</p>
<p>4. Warpage of PC board</p>	<p>Maximum of 0.02mm at the connector center, with both ends of the connector as reference points.</p>
<p>5. Cleaning Condition</p>	<p>Cleaning with IPA is possible. (Cleaning is not recommended. In case of cleaning, please evaluate if it causes a decrease in the performance which includes mechanical operation and environmental resistance.)</p>
<p>6. Precautions</p>	<ul style="list-style-type: none"> ■ When inserting crimp-type (solderless) terminals to crimping (solderless) sockets, to maintain reliable performance, please do not insert obliquely. ■ DO NOT mate/un-mate a non-terminated plug with a non-mounted receptacles. This may lead to damage or deformation of the contacts. ■ Please note that pulling on the wires or cable during un-mating may cause damage. ■ DO NOT apply flux to the contact terminals when hand soldering the receptacle to the board. Flux can wick into the electrical contact areas and may lead to connection failures. ■ Slight discoloration on the insulating materials will not affect form, fit or function of the connectors. Black spots may appear on the mold resin but this does not affect the product quality. ■ Please refer to the following for the points for proper handling regarding mating/unmating operations. “DF59 Insertion and Removal Manual” ETAD-H0496-00 “DF59S Insertion and Removal Manual” ETAD-H0651-00 “DF59M Operation manual” ETAD-H0779-00

Mar.1.2026 Copyright 2026 HIROSE ELECTRIC CO., LTD. All Rights Reserved.

