

Waterproof Circular Connectors

JR-W Series



■ Features

1. Waterproof

The JR-W series is a rugged, waterproof connector series that is IP67 and IP68 rated in the mated condition.

IP67 : Left in water at a depth of 1m for 30 minutes

IP68 : Left in water at a depth of 2m for 14 days

2. Corrosion resistance

The outer shell is plated to improve corrosion resistance, allowing this connector to be used in various environments.

■ Product Specifications

Ratings	Current rating	Shell size	No. of contacts	Current rating
		13	5	5A
		16	7	10A
			10	5A
25	4	30A		
	24	5A		
Ratings	Voltage rating	Shell size	No. of contacts	Voltage rating
		13	5	100V AC, 140V DC
			7	
		16	10	100V AC, 140V DC
			4	
		25	24	300V AC, 420V DC
			100V AC, 140V DC	
Ratings	Operating temperature range	-25 to +85°C		
	Storage temperature range	-10 to +60°C		

Item	Specifications	Conditions
1. Contact resistance	5mΩ max. JR16-10 contact crimping type : 10mΩ max.	Measured at DC 1A
2. Insulation resistance	1,000MΩ min. JR25-4 contacts : 10,000MΩ min.	Measured at DC 500V
3. Withstanding voltage	No flashover or dielectric breakdown.	AC 1,000V for 1 minute JR25-4 contacts : AC 3,000V for one minute
4. Vibration resistance	No electrical discontinuity for 10μs or greater.	10 to 55Hz/cycle, amplitude : 0.75mm, 3 axis directions, 2 hours each.
5. Shock resistance	No electrical discontinuity for 10μs or greater.	Acceleration : 490m/s ² , duration : 11ms 6 directions, 3 times each.
6. Mating cycles	Contact resistance : 5mΩ max. JR16-10 contact crimping type : 10mΩ max.	500 times
7. Temperature cycle	Insulation resistance : 1,000MΩ min. JR25-4 contacts : 10,000MΩ min.	-40°C : 30 minute → Normal temperature : 10 to 15 minutes → 100°C : 30 minutes → Normal temperature : 10 to 15 minutes, left for 5 cycles
8. Moisture resistance	Insulation resistance: 10MΩ min. (at high humidity) 100MΩ min. (when dry) JR25-4 contacts: 100MΩ min. (at high humidity) 1,000MΩ min. (when dry)	Temperature : 40°C, relative humidity : 90 to 95%, leave 96 hours
9. Waterproof	No water penetration into the connector.	Mated connectors left in water at a depth of 1.8m for 48 hours.

Materials / Finish

Parts	Material	Finish	Remarks
Outer shell	Aluminium alloy, brass	Black chromium plating	————
Insulator	Phenol resin, PPS resin	————	UL94V-0
Contact	Copper alloy	Silver plating	————
Waterproof packing	Nitrile rubber, silicone rubber	————	————

Product Number Structure

Refer to the chart below when determining the product specifications from the product number.
Please select from the product numbers listed in this catalog when placing orders.

● Plug and receptacle

JR 13 WP A - 3 P C ()**

① ② ③ ④ ⑤ ⑥ ⑦ ⑧ ⑨

● Cord clamp

JR 13 WCC A - 4 ()**

① ② ③ ④ ⑧ ⑨

① Model name : JR Series
② Shell size : Shell size is the outer shell diameter of the mating end of the plug.
③ Shell type WP : Waterproof plug WR : Waterproof receptacle WCC : Waterproof clamp
④ Shell variation : Connectors are distinguished by A, B, or C if a shell variation is applied in the same form.
⑤ Number of contacts.
⑥ Contact form P : Male Contact S : Female Contact
⑦ Contact termination method None : Solder termination C : Crimp termination
⑧ Applicable cable diameter
⑨ Other specifications : A two-digit number is added to indicate other specifications.

■ Soldering type

● Plug

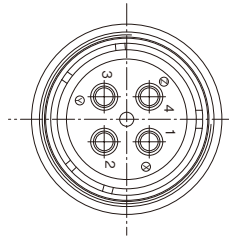

(Representative example)

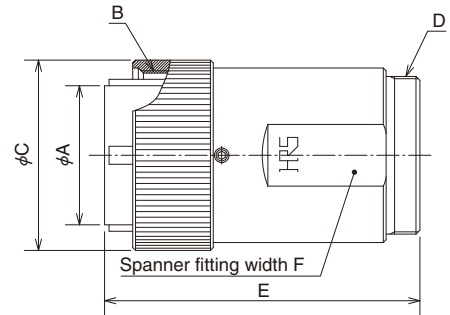

Part No.	HRS No.	No. of contacts	ϕA	B	ϕC	D	E	F	Remarks
JR13WP-5P(31)	114-2002-8 31	5	12.7	M18×1	21.8	M16×0.75	44.7	17	
JR16WP-7P(31)	114-2003-0 31	7	16.3	M22×1	25.8	M20×0.75	46.5	21	
JR25WPH-4P	114-2185-0	4	24.7	M30×1	33.8	M28×0.75	56	29	☆
JR25WP-24P(31)	114-2011-9 31	24							
JR13WP-5S(31)	114-2013-4 31	5	12.7	M18×1	21.8	M16×0.75	44.7	17	
JR16WP-7S(31)	114-2014-7 31	7	16.3	M22×1	25.8	M20×0.75	46.5	21	
JR25WPH-4S	114-2183-4	4	24.7	M30×1	33.8	M28×0.75	56	29	☆
JR25WP-24S(31)	114-2022-5 31	24							

Note 1 : Plugs must be used with cord clamps.

Note 2 : ☆ : Denotes waterproof gaskets with a silicone rubber specification

● Receptacle (Flange type)

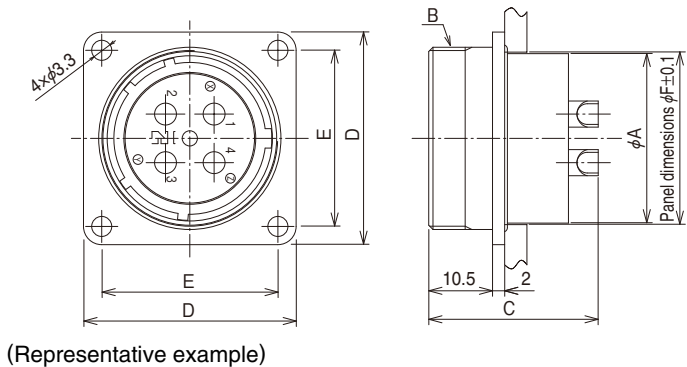

Part No.	HRS No.	No. of contacts	φA	B	C	D	E	φF	Remarks
JR13WR-5P(31)	114-2024-0 31	5	15.9	M18×1	26.1	26	20	16.3	
JR16WR-7P(31)	114-2025-3 31	7	19.9	M22×1	26.6	29	23	20.3	
JR25WRH-4P	114-2184-7	4	27.9	M30×1	28	35	29	28.3	☆
JR25WR-24P(31)	114-2033-1 31	24			26.1				
JR13WR-5S(31)	114-2035-7 31	5	15.9	M18×1	27	26	20	16.3	
JR16WR-7S(31)	114-2036-0 31	7	19.9	M22×1	28	29	23	20.3	
JR25WRH-4S	114-2186-2	4	27.9	M30×1	28	35	29	28.3	☆
JR25WR-24S(31)	114-2044-8 31	24			27				

Note 1 : ☆ : Denotes waterproof gaskets with a silicone rubber specification

■ Soldering type

● Receptacle (Front nut-tightening type)

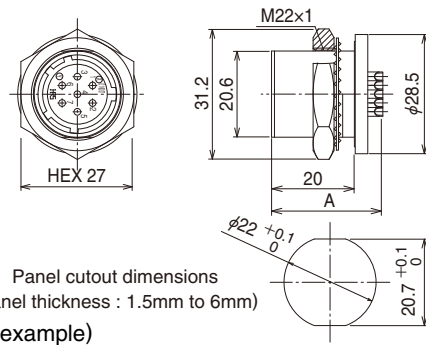

Panel cutout dimensions
(Panel thickness : 1.5mm to 6mm)

(Representative example)

Part No.	HRS No.	No. of contacts	A
JR16WRA-7P(31)	114-2143-0 31	7	26.6

● Receptacle (Rear nut-tightening type with hex nut)

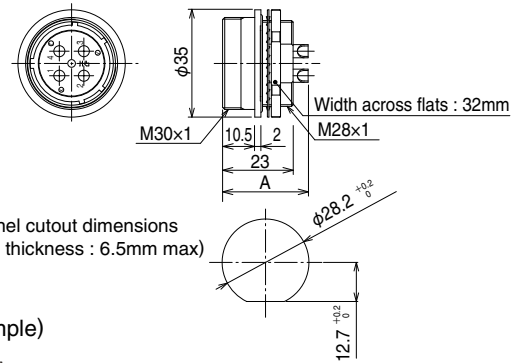

Panel cutout dimensions
(Panel thickness : 6.5mm max)

(Representative example)

Part No.	HRS No.	No. of contacts	A	Remarks
JR25WRHA-4P	114-1136-9	4	28	☆
JR25WRHA-4S	114-1135-6			

Note 1 : ☆ : Denotes waterproof gaskets with a silicone rubber specification

■ Crimp type

● Plug

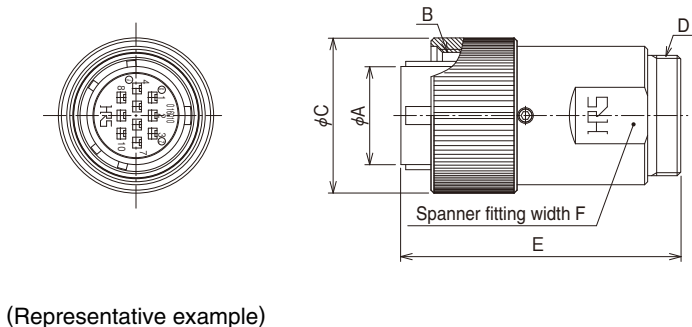

Part No.	HRS No.	No. of contacts	φA	B	φC	D	E	F	Contact dia.
JR16WP-10PC(31)	114-2114-1 31	10	16.3	M22×1	25.8	M20×0.75	46.5	21	1
JR16WP-10SC(31)	114-2122-0 31		16.3	M22×1	25.8	M20×0.75	46.5	21	1

Note 1 : Plugs must be used with cord clamps.

● Receptacle(Flange type)

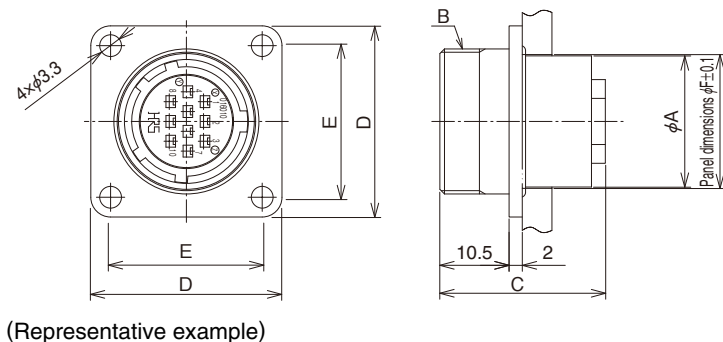

Part No.	HRS No.	No. of contacts	φA	B	C	D	E	φF	Contact dia.
JR16WR-10PC(31)	114-2130-8 31	10	19.9	M22×1	25.1	29	23	20.3	1

Apr. 1. 2024 Copyright 2024 HIROSE ELECTRIC CO., LTD. All Rights Reserved.

● Cable clamp (Standard type)

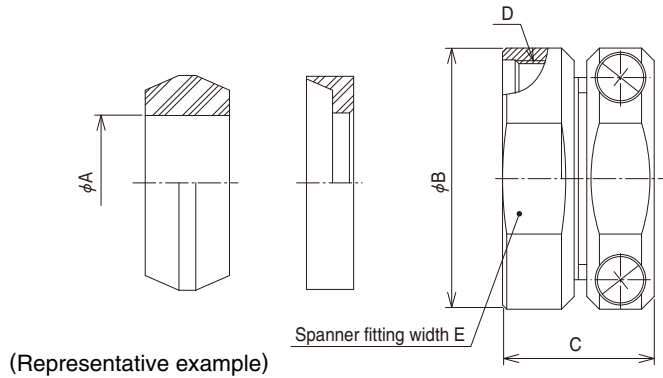

Part No.	HRS No.	ϕA	ϕB	C	D	E
JR13WCC-4(31)	114-2045-0 31	4	20	17	M16×0.75	17
JR13WCC-5(31)	114-2046-3 31	5				
JR13WCC-6(71)	114-2047-6 71	6				
JR13WCC-7(31)	114-2048-9 31	7				
JR13WCC-8(31)	114-2049-1 31	8				
JR13WCC-9(31)	114-2050-0 31	9				
JR13WCC-10(31)	114-2051-3 31	10				
JR16WCC-4(71)	114-2052-6 71	4	23	17.5	M20×0.75	21
JR16WCC-6(71)	114-2053-9 71	6				
JR16WCC-8(71)	114-2054-1 71	8				
JR16WCC-10(71)	114-2055-4 71	10				
JR16WCC-12(71)	114-2056-7 71	12				
JR25WCC-8(71)	114-2063-2 71	8	31	18	M28×0.75	29
JR25WCC-10(71)	114-2064-5 71	10				
JR25WCC-12(31)	114-2065-8 31	12				
JR25WCC-14(31)	114-2066-0 31	14				
JR25WCC-16(31)	114-2067-3 31	16				
JR25WCC-18(71)	114-2068-6 71	18				

● Cable clamp (Simple type)



JR13WCCA-6(71)

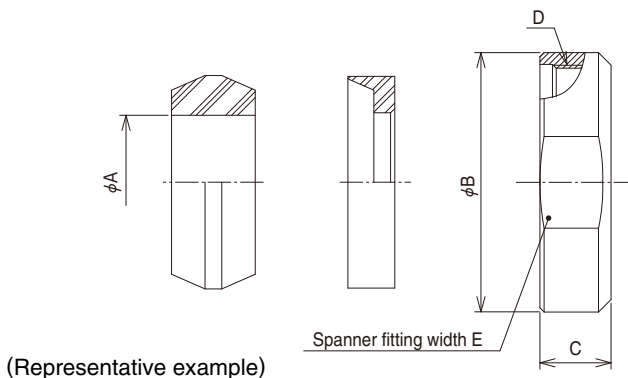

(Representative example)

Part No.	HRS No.	ϕA	ϕB	C	D	E
JR13WCCA-4(31)	114-2069-9 31	4	19	7.5	M16×0.75	17
JR13WCCA-5(31)	114-2070-8 31	5				
JR13WCCA-6(71)	114-2071-0 71	6				
JR13WCCA-7(31)	114-2072-3 31	7				
JR13WCCA-8(31)	114-2073-6 31	8				
JR13WCCA-9(31)	114-2074-9 31	9				
JR13WCCA-10(31)	114-2075-1 31	10	23	8	M20×0.75	21
JR16WCCA-4(71)	114-2076-4 71	4				
JR16WCCA-6(71)	114-2077-7 71	6				
JR16WCCA-8(71)	114-2078-0 71	8				
JR16WCCA-10(71)	114-2079-2 71	10				
JR16WCCA-12(71)	114-2080-1 71	12				
JR25WCCA-8(71)	114-2087-0 71	8	31	8.5	M28×0.75	29
JR25WCCA-10(71)	114-2088-3 71	10				
JR25WCCA-12(31)	114-2089-6 31	12				
JR25WCCA-14(31)	114-2090-5 31	14				
JR25WCCA-16(31)	114-2091-8 31	16				
JR25WCCA-18(71)	114-2092-0 71	18				

Note : The simple cord clamp does not have the cable clamping ability as the standard cable clamp does. We recommend that you make sure that the clamping capability of the simple cord clamp is sufficient for your application.

●Cap (Without a chain)

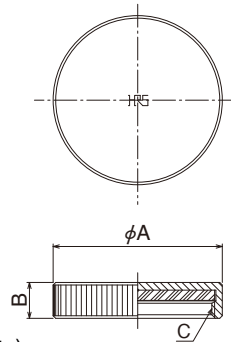

(Representative example)

Part No.	HRS No.	φA	B	C	Remarks
JR13WRC4	114-2192-5	21	7	M18×1	☆
JR13WRC5	114-2105-0		7.5		☆, Plastic shell
JR16WRC(31)	114-2162-4 31	25	7	M22×1	☆
JR16WRC(75)	114-2162-4 75				☆
JR25WRC(31)	114-2163-7 31	33	7.5	M30×1	☆
JR25WRC(75)	114-2163-7 75				☆
JR25WRC5	114-2175-6				☆, Plastic shell

Note 1 : ☆ : Denotes waterproof gaskets with a silicone rubber specification

●Cap (With a chain)

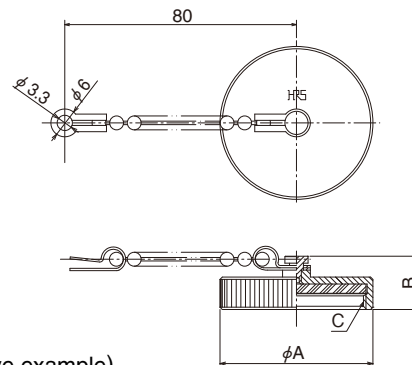

(Representative example)

Part No.	HRS No.	φA	B	C	Remarks
JR13WRC3	114-2170-2	21	11.5	M18×1	☆
JR16WRC3	114-2171-5	25		M22×1	
JR25WRC3	114-2172-8	33		M30×1	

Note 1 : ☆ : Denotes waterproof gaskets with a silicone rubber specification

◆ Crimp contacts

■ Contact diameter $\phi 1.0\text{mm}$

● Male contact

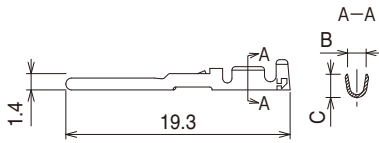

Type	Part No.	HRS No.	B	C	Applicable wire
Loose contacts	JRC-PC2-112	114-0243-3	1.6	2.0	20 to 24 AWG
	JRC-PC2-122	114-0244-6	1.45	1.5	24 to 28 AWG
Reel contacts	JRC-PC2-212	114-0245-9	1.6	2.0	20 to 24 AWG
	JRC-PC2-222	114-0246-1	1.45	1.5	24 to 28 AWG

● Female contact

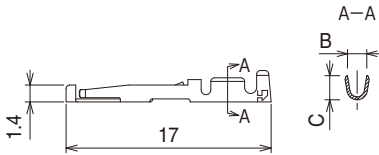

Type	Part No.	HRS No.	B	C	Applicable wire
Loose contacts	JRC-SC2-112	114-0247-4	1.6	2.0	20 to 24 AWG
	JRC-SC2-122	114-0248-7	1.45	1.5	24 to 28 AWG
Reel contacts	JRC-SC2-212	114-0249-0	1.6	2.0	20 to 24 AWG
	JRC-SC2-222	114-0250-9	1.45	1.5	24 to 28 AWG

Note : Loose contacts come in packages of 100 pcs.

Reel contacts come in reels of 8,000 pcs.

◆ Tools

Contact dia.	Type	Item	Part No.	HRS No.	Applicable contact	Applicable wire	
$\phi 1$	Manual	Manual crimping tool	HT802 / RM-11	150-0401-6	JRC-PC2-112 JRC-SC2-112	20 to 24 AWG	
			HT802 / RM-12	150-0402-9	JRC-PC2-122 JRC-SC2-122	24 to 28 AWG	
	Automatic	Automatic crimping machine body	CM-105C	901-0001-0	—	—	
			Applicator	AP105-JRC2-1	901-2037-1	JRC-PC2-212 JRC-SC2-212	20 to 24 AWG
				AP105-JRC2-2	901-2038-4	JRC-PC2-222 JRC-SC2-222	24 to 28 AWG
	Extractor	RM-TP	150-0008-7	—	—		

◆ Plug assemblies procedure

○ The receptacle side is omitted because no special procedures are required.

● Diagrammatical view

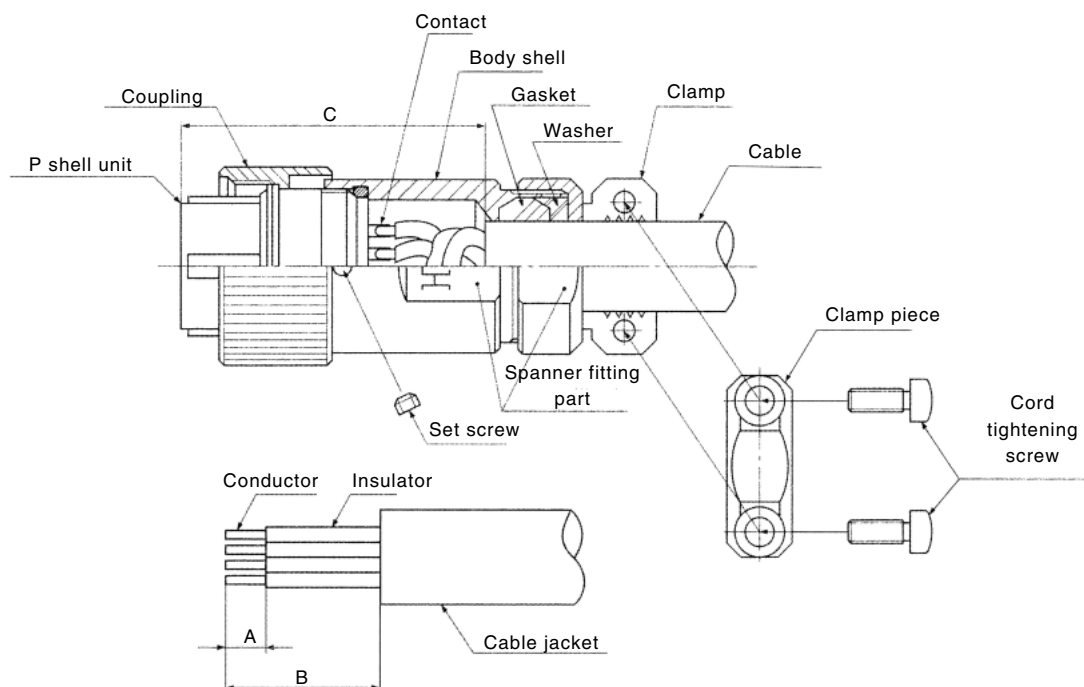

○ Work procedure

1. Disassembly of connector

- (1) To remove the plug, remove the set screw, fit a receptacle adaptive to the P shell unit to fix, and remove the cord tube.
- (2) To remove the cord clamp, remove the cord tightening screws. (Note 1)

2. Connection

2.1 Soldering type

- (1) Use the cable so that the conductor can be soldered properly into the solder pot with the cable sheath diameter adaptive to each cord clamp.
- (2) After the terminal treatment of the cable with a size given in Table 1, thread on the cable the clamp, washer, gasket, cord tube and coupling in this order and direction as shown above.
- (3) Solder to connect the conductors to the terminals of the P shell unit. Shrinkable tube is recommended to be used at the connecting part because insulating performance might deteriorate due to solder whiskers or dewing. After connecting, adjust to meet the C size. (Note 2)

2.2 For crimping type connectors

- (1) Please make sure to use a cable with the correct outer diameter for the cord clamp. It is also important that the wire and its outer diameter are appropriate for the crimp contacts.
- (2) Pass the cables in order through the 1) tightening fitting, 2) washer, 3) gasket, 4) cord tube, and 5) coupling in the direction shown on the above figure, following terminal treatment as shown in Table-2.
- (3) After crimping the applicable crimping contacts onto the conductor, insert the crimping contacts into the contact holes of the P-shell unit. After inserting, please make adjustments so that the dimension for Section C shall be satisfied. Note 2)

3. Assembly of connector

- (1) Fit the connected P shell unit to the receptacle fixed with a vice or the like. Torque the cord tube to the level as given in Table-3.
- (2) Fit the gasket, washer and clamp. Torque the clamp to the level as given in Table-3 while preventing the cable from being rotated. And, Loctite Japan Co Ltd. is recommended to be applied as locking. (Note 3)
- (3) Torque the set screw to 0.2 to 0.25N·m.
- (4) Torque the cord tightening screw (two positions) to 0.65 to 0.7N·m. (Note 1, 3)

Note 1 : Not required if a simple type cord clamp is used.

Note 2 : Please maintain this dimension until assembly is complete.

Note 3 : Cable clamping force, cable rotation force, and others aspects may differ depending on the cable construction.

We recommend that you verify the suitability of the cable assembly before use or production.

Table 1 (Solder type) [unit : mm]

Shell size	A	B	C
13	(3)	(12)	37 MAX.
16	(3)	(14)	39 MAX.
25	(3)	(20)	45 MAX.

Table 2 (Crimp type) [unit : mm]

Shell size	No. of contacts	A	B	C
16	10	3.5 to 4	(19)	39 MAX.

Table 3 [unit : N·m]

Shell size	Tightning torque
13	2 to 2.5
16	3 to 3.5
25	5 to 5.5

◆ Contact position arrangement

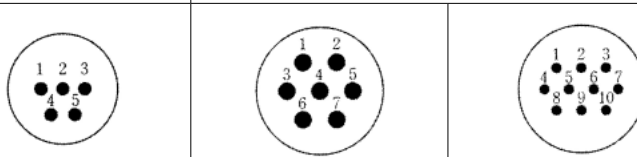
Shell size 13, 16	13	16	
			
No. of contacts	5	7	10
Withstand voltage	1,000V AC for 1 minute		
Current capacity	5A	10A	5A
Insulation resistance	1,000MΩ MIN.		
Contact resistance	5mΩ MAX.		
Solderpot inner diameter	1.1mm dia.	1.7mm dia.	1.1mm dia.

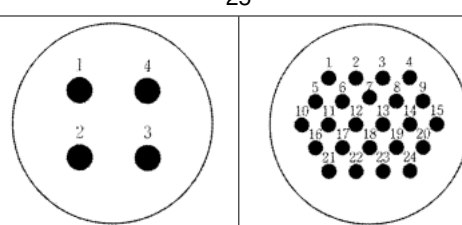
Shell size 25	25	
		
No. of contacts	4	24
Withstand voltage	3,000V AC for 1 minute	1,000V AC for 1 minute
Current capacity	30A	5A
Insulation resistance	10,000MΩ MIN.	1,000MΩ MIN.
Contact resistance	5mΩ MAX.	5mΩ MAX.
Solderpot inner diameter	3.4mm dia.	1.1mm dia.

Remarks 1. Figures are views of contact arrays of the mating end of male connectors.
 2. The withstand voltage indicates the test voltage value.

◆ Precautions

1. Switch off the power of the circuit before disconnecting or plugging-in the connectors.
2. Use connectors with socket contacts at the power side of the circuit.
3. Make sure that the coupling is in completely cocked position.
4. Use the connector as the combination of water-proof types.
5. This product series uses silver plated contacts. Silver reacts easily to exposure to sulfur gas so the below conditions may cause tarnishing.
 - Dusty environments
 - Area with a high concentration area of gases such as sulfur dioxide gas, hydrogen sulfide gas, nitrogen dioxide gas and so on.
 Example; In close proximity to factory exhaust, automotive emissions, etc.
 - Close to heaters, or in other areas marked by extreme temperature differences or high humidity.
 - Close to rubber products includes rubber adhesives.

The Electrical connection is not affected by tarnishing on a silver surface due to the wiping effect of the contact pins.

Storage

Packing state; Packed in original packing or equivalent container

Temperature -10 to +60°C

Humidity 85% Max

(It is recommended that the product be stored in an area of normal level of temperature and humidity, and free of any temperature fluctuation)

Please use this products within 6 months of delivery.

(After 6 month, please check the solderbility before use)

“Storage” means long-term storage of the unused products in sealed packaging, prior to assembly to PCB.

HIROSE ELECTRIC CO.,LTD.

2-6-3,Nakagawa Chuoh,Tsuzuki-Ku,Yokohama-Shi 224-8540,JAPAN
<https://www.hirose.com/>