

## ZE05 Series

# High Heat and Vibration Resistance, 0.5 Size, 2mm pitch Automotive Interface Connector

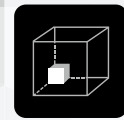

Low Profile



Space Saving



Contact Reliability

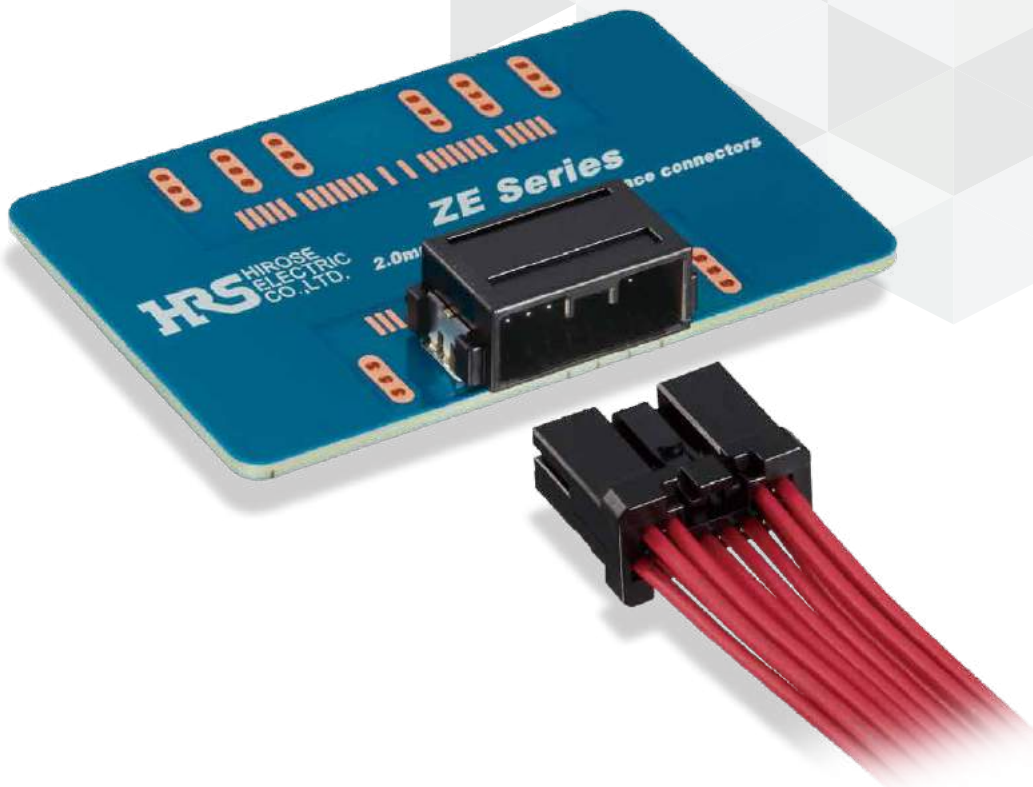

# Features

## 1. Space-saving

0.5 size terminal, 2mm pitch.  
 Contributes to end product size reduction

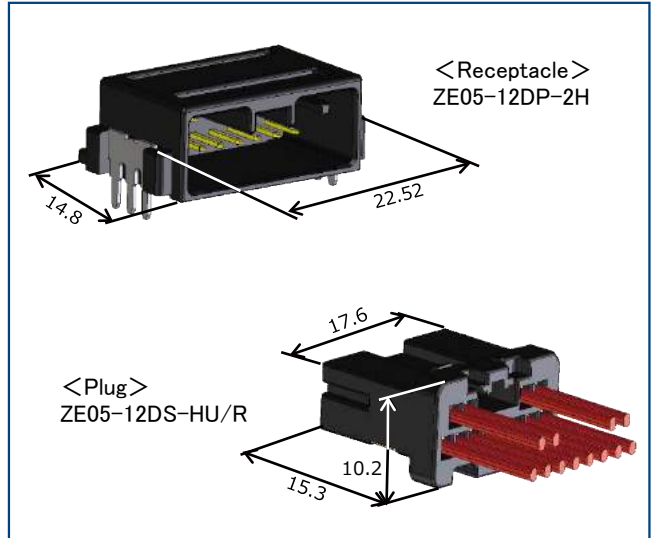

## 2. High Heat Resistance : up to 125°C

- Up to 125°C
- Suitable for automotive and other high-heat applications

Note : Includes the temperature rise due to current flow.

## 3. High Vibration Resistance

- Female terminal with original 3-point contact design
- Double-layered spring for stability
- Maintains contact under intense vibration, enhancing reliability

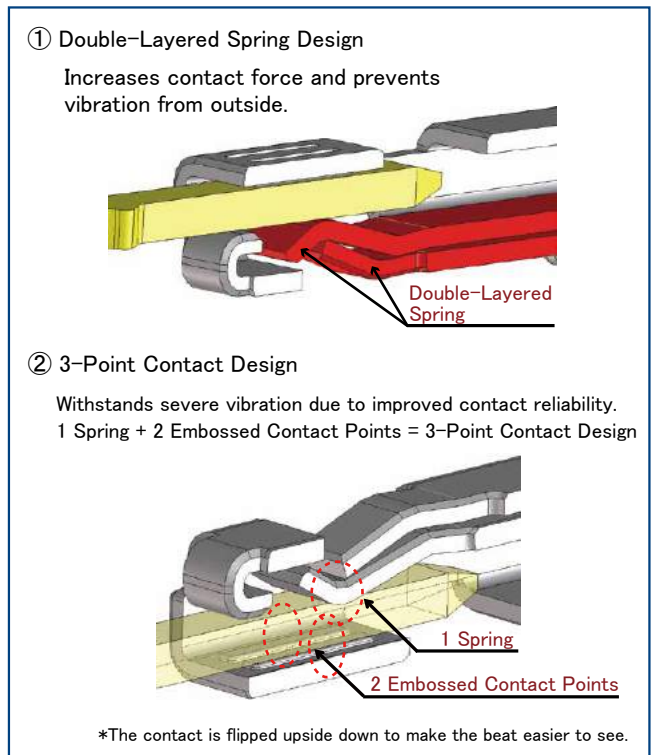

High Vibration Resistance Terminal Design

## 4. Rated Current :

5A (Single pin power supply)  
 / 2A (All pins power supply)

## 5. Retainer Guarantees 40N Tensile Strength

Design Resistant to Cable Routing

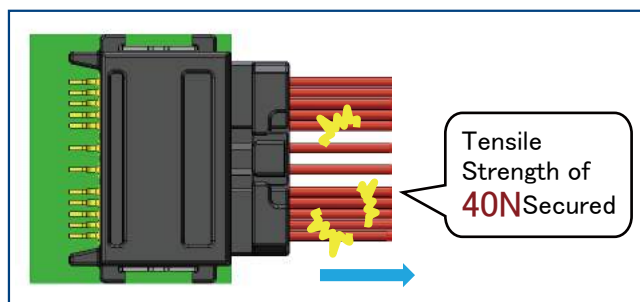

## 6. Wide Position Varieties (2, 4, 5, 8, 12, 16, 20, 24)

### Product Specifications

Rated Current	2A (All pins power supply) 5A (Single pin power supply)	Operating Temperature (Note1)	-40 to +125°C
Rated Voltage	60V AC/DC	Storage Temperature (Note2)	-10 to +60°C
		Storage Humidity Range (Note2)	Relative humidity 85% Max. (No condensation)

Items	Specifications	Conditions
Contact Resistance	10m Ω Max.	Measured at 1A DC
Insulation Resistance	100M Ω Min.	Measured at 500V DC
Withstanding Voltage	No insulation breakdown	1000V AC for 1 min.
Mating Durability	Contact Resistance : 20m Ω Max.	30 Insertion/Extraction cycles
Vibration Resistance	No electrical discontinuity of 1 μs or more. Contact Resistance : 20m Ω Max.	Frequency : 20 to 200Hz (Constant Acceleration of 88m/s <sup>2</sup> ) 1 Cycle 3 min. (round trip), 3 hours in 3 directions
Lock Strength	100N Min.	Lock breaking strength measured when pulling in mating axis direction
Humidity Resistance	Contact Resistance : 20m Ω Max. Insulation Resistance : 100M Ω Min.	Left for 96 hours at a temperature of 60°C and a relative humidity 90 to 95%
Thermal Shock	Contact Resistance : 20m Ω Max.	Temperature : -40°C → Room temperature → +125°C → Room temperature Time : 30 → 5 → 30 → 5 minutes for 1000 cycles
Heat Resistance	Contact Resistance : 20m Ω Max.	Left at 140°C for 120 hours
Cold Resistance	Contact Resistance : 20m Ω Max.	Left at -40°C for 120 hours
Sulfuric Acid Gas Resistance	Contact Resistance : 20m Ω Max.	Left in sulfuric acid gas at room temperature with a concentration of 25ppm and 75% or more RH for 96 hours while unmated

Note 1 : Includes the temperature rise due to current flow.

Note 2 : Storage refers to long-term storage of unused items before they are mounted on the PCB.

Operating temperature and humidity range apply when the product is not powered after PCB mounting and when temporarily stored during transportation.

## Materials / Finish

Component	Part	Material	Color / Finish	UL Standard
Receptacle	Housing	PA Rasin	Black, Gray, Violet	UL94V-0
	Terminal	Brass	Tin Plating	-
	Retention Tab	Brass	Tin Plating	-
Plug	Housing	PA Rasin	Black, Gray, Violet	UL94V-0
	Retainer	PA Rasin	Natural	UL94V-0
Crimp Terminal	Terminal	Copper Alloy	Tin Plating	-

## Product Number Structure

Refer to the chart below when determining the product specifications from the product number. Please select from the product numbers listed in this catalog when placing orders.

### ■ Receptacle / Plug

**ZE05 H - 8 D P - 2 H (A)**

① ② ③ ④ ⑤ ⑥ ⑦ ⑧

### ■ Crimp Terminal

**ZE05 - 2022 SCF**

① ⑨ ⑩

① Series Name	ZE05	⑥ Pitch	2mm
② Retention Tab	H : SMT None : THR (Through Hole Reflow)	⑦ Part Type	H : Right Angle V : Straight HU/R : Housing/ Retainer
③ No. of Pos.	2, 4, 5, 8, 12, 16, 20, 24	⑧ Mating Key	None : Standard, A, B
④ Row	None : Single-row D : Double-row	⑨ Applicable Cable Size	20 to 22 AWG (0.3 to 0.5 sq)
⑤ Connector Type	P : Receptacle S : Plug	⑩ Form Type/ Packaging	Female terminal, Reel

# Combination Chart

## Receptacle



ZE05H-##P-2H



ZE05-##P-2H

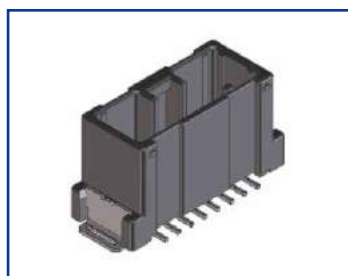

ZE05H-##P-2V

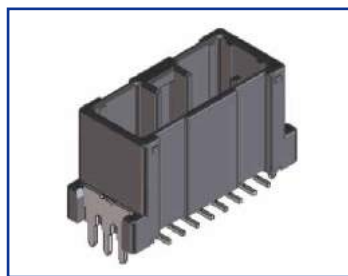

ZE05-##P-2V

## Plug



ZE05-##S-HU/R

## Crimp Terminal



ZE05-2022SCF

## Right Angle Receptacle

### SMT Retention Tab

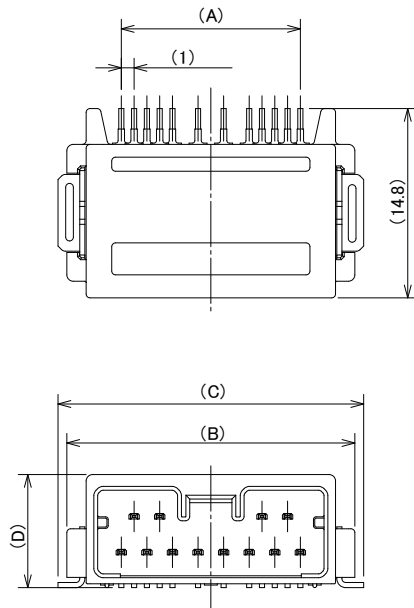

Unit : mm

Part No.	HRS No.	Color	Mating Key	No. of Pos.	A	B	C	D	Purchase Unit
ZE05H-2P-2H	CL0752-2109-0-00	Black	Standard	2	2.0	12.32	13.7	8.34	300pcs per reel
ZE05H-2P-2H(B)	Under Planning (Note 1)	Violet	B Key						
ZE05H-4P-2H	CL0752-2110-0-00	Black	Standard	4	6.0	16.32	17.7		
ZE05H-4P-2H(A)	CL0752-2127-0-00	Gray	A Key						
ZE05H-5P-2H	CL0752-2120-0-00	Black	Standard	5	8.0	18.32	19.7		
ZE05H-8DP-2H	CL0752-2112-0-00	Black	Standard	8	10.0	18.52	19.9		
ZE05H-8DP-2H(A)	CL0752-2122-0-00	Gray	A Key						
ZE05H-8DP-2H(B)	CL0752-2123-0-00	Violet	B Key						
ZE05H-12DP-2H	CL0752-2113-0-00	Black	Standard	12	14.0	22.52	23.9		
ZE05H-16DP-2H	CL0752-2114-0-00	Black	Standard	16	20.0	28.52	29.9	8.84	
ZE05H-20DP-2H	CL0752-2115-0-00	Black	Standard	20	26.0	34.52	35.9		
ZE05H-20DP-2H(A)	CL0752-2133-0-00	Gray	A Key						
ZE05H-24DP-2H	CL0752-2116-0-00	Black	Standard	24	30.0	38.52	39.9		
ZE05H-24DP-2H(A)	CL0752-2132-0-00	Gray	A Key						

Note 1 : Products without HRS No. are currently being planned for development. Contact a Hirose representative regarding questions on pin count variation development.

Note 2 : Depopulated version and UL certified specifications are also available. For details, please contact a Hirose representative.

## THR (Through Hole Reflow) Retention Tab

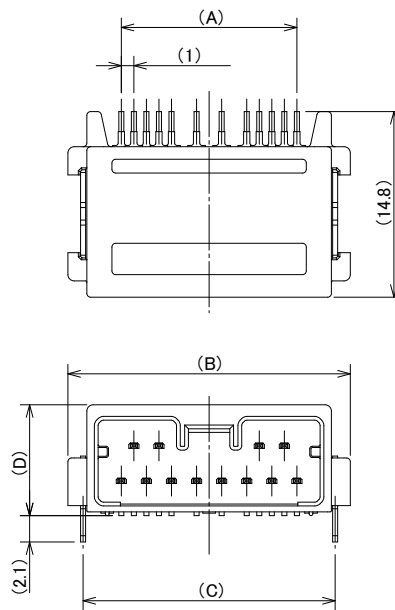

Unit : mm

Part No.	HRS No.	Color	Mating Key	No. of Pos.	A	B	C	D	Purchase Unit
ZE05-2P-2H	CL0752-2100-0-00	Black	Standard	2	2.0	12.32	9.9	8.34	300pcs per reel
ZE05-4P-2H	CL0752-2101-0-00	Black	Standard	4	6.0	16.32	13.9		
ZE05-4P-2H(A)	CL0752-2128-0-00	Gray	A Key						
ZE05-5P-2H	CL0752-2121-0-00	Black	Standard	5	8.0	18.32	15.9	8.84	
ZE05-8DP-2H	CL0752-2103-0-00	Black	Standard	8	10.0	18.52	16.1		
ZE05-12DP-2H	CL0752-2104-0-00	Black	Standard	12	14.0	22.52	20.1		
ZE05-16DP-2H	CL0752-2105-0-00	Black	Standard	16	20.0	28.52	26.1		
ZE05-20DP-2H	CL0752-2106-0-00	Black	Standard	20	26.0	34.52	32.1		
ZE05-20DP-2H(A)	CL0752-2119-0-00	Gray	A Key						
ZE05-24DP-2H	CL0752-2107-0-00	Black	Standard	24	30.0	38.52	36.1		
ZE05-24DP-2H(A)	CL0752-2124-0-00	Gray	A Key						

Note : Depopulated version and UL certified specifications are also available.  
For details, please contact a Hirose representative.

## Straight Receptacle

### SMT Retention Tab

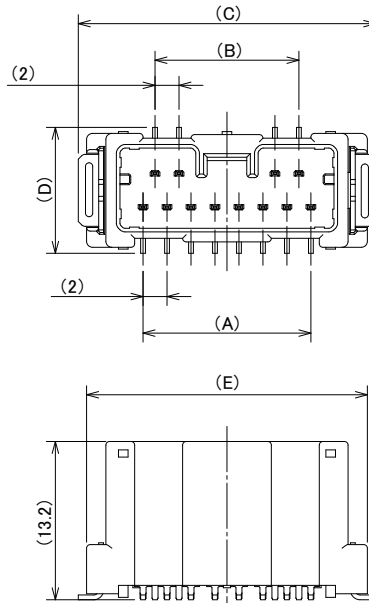

Unit : mm

Part No.	HRS No.	Color	Mating Key	No. of Pos.	A	B	C	D	E	Purchase Unit
ZE05H-2P-2V	CL0752-2309-0-00	Black	Standard	2	2.0	-	14.6	10.0	13.22	250pcs per reel
ZE05H-2P-2V(B)	Under Planning (Note 1)	Violet	B Key						17.22	
ZE05H-4P-2V	CL0752-2310-0-00	Black	Standard	4	6.0	-	18.6	10.5	19.42	
ZE05H-4P-2V(A)	CL0752-2320-0-00	Gray	A Key						23.42	
ZE05H-8DP-2V	CL0752-2312-0-00	Black	Standard	8	10.0	8.0	20.8	29.42		
ZE05H-12DP-2V	CL0752-2313-0-00	Black	Standard	12	14.0	12.0	24.8	39.42		
ZE05H-16DP-2V	CL0752-2314-0-00	Black	Standard	16	18.0	20.0	30.8			
ZE05H-24DP-2V	CL0752-2316-0-00	Black	Standard	24	30.0	28.0	40.8			

Note 1 : Products without HRS No. are currently being planned for development. Contact a Hirose representative regarding questions on pin count variation development.

Note 2 : Suction tape is attached as a standard.

Note 3 : Depopulated version and UL certified specifications are also available. For details, please contact a Hirose representative.



## THR (Through Hole Reflow) Retention Tab

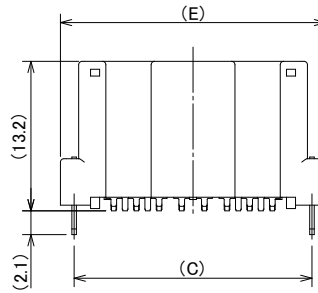
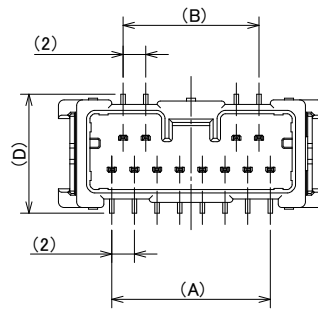

Unit : mm

Part No.	HRS No.	Color	Mating Key	No. of Pos.	A	B	C	D	E	Purchase Unit
ZE05-2P-2V	CL0752-2300-0-00	Black	Standard	2	2.0	-	10.8	10.0	13.22	250pcs per reel
ZE05-4P-2V	CL0752-2301-0-00	Black	Standard	4	6.0	-	14.8		17.22	
ZE05-8DP-2V	CL0752-2303-0-00	Black	Standard	8	10.0	8.0	17.0	10.5	19.42	
ZE05-12DP-2V	CL0752-2304-0-00	Black	Standard	12	14.0	12.0	21.0		23.42	
ZE05-16DP-2V	CL0752-2305-0-00	Black	Standard	16	18.0	20.0	27.0		29.42	
ZE05-24DP-2V	Under Planning (Note 1)	Black	Standard	24	30.0	28.0	37.0		39.42	

Note 1 : Products without HRS No. are currently being planned for development. Contact a Hirose representative regarding questions on pin count variation development.

Note 2 : Suction tape is attached as a standard.

Note 3 : Depopulated version and UL certified specifications are also available.  
For details, please contact a Hirose representative.

## Plug

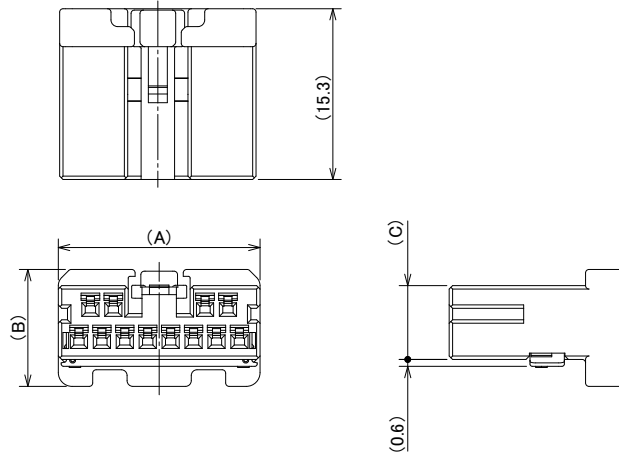

Unit : mm

Part No.	HRS No.	Color	Mating Key	No. of Pos.	A	B	C	Purchase Unit
ZE05-2S-HU/R	CL0752-2200-0-00	Black	Standard	2	8.8	9.7	5.3	350pcs per box
ZE05-2S-HU/R(B)	Under Planning (Note 1)	Violet	B Key					
ZE05-4S-HU/R	CL0752-2201-0-00	Black	Standard	4	12.8			
ZE05-4S-HU/R(A)	CL0752-2216-0-00	Gray	A Key					
ZE05-5S-HU/R	CL0752-2211-0-00	Black	Standard	5	14.8			
ZE05-8DS-HU/R	CL0752-2203-0-00	Black	Standard	8	13.6	10.2	6.44	
ZE05-8DS-HU/R(A)	CL0752-2212-0-00	Gray	A Key					
ZE05-8DS-HU/R(B)	CL0752-2213-0-00	Violet	B Key					
ZE05-12DS-HU/R	CL0752-2204-0-00	Black	Standard	12	17.6			280pcs per box
ZE05-16DS-HU/R	CL0752-2205-0-00	Black	Standard	16	23.6			
ZE05-20DS-HU/R	CL0752-2206-0-00	Black	Standard	20	29.6			245pcs per box
ZE05-20DS-HU/R(A)	CL0752-2210-0-00	Gray	A Key					
ZE05-24DS-HU/R	CL0752-2207-0-00	Black	Standard	24	33.6	210pcs per box		
ZE05-24DS-HU/R(A)	CL0752-2214-0-00	Gray	A Key					

Note 1 : Products without HRS No. are currently being planned for development. Contact a Hirose representative regarding questions on pin count variation development.

Note 2 : Depopulated version and UL certified specifications are also available. For details, please contact a Hirose representative.

## Crimp Terminal for Plug

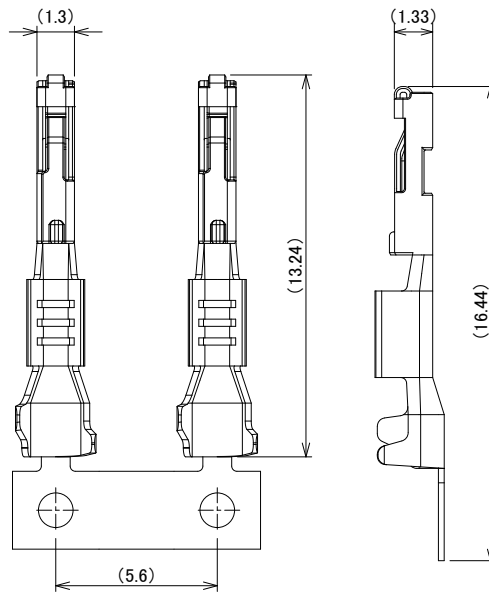

Part No.	HRS No.	Applicable Cable	Purchase Unit
ZE05-2022SCF	CL0752-2001-0-00	20 to 22 AWG (0.3 to 0.5sq) Coated Outer Diameter : $\phi$ 1.6mm [AESSX etc]	10,000pcs per reel

## Applicable Tools

Type	Part No.	HRS No.	Compatible Crimp Terminal
Hirose Crimping Tool	CM-105C	CL0901-0001-0-00	-
Applicator for Hirose Crimping Tool	AP105-ZE05-2022S	CL0901-5239-0-00	ZE05-2022SCF
Japan Automatic Machine Applicator (Note 1)	CHX022700H	-	ZE05-2022SCF
Hand Tool (Note 2)	HT802/ZE05-2022S (Note 3)	CL0780-0045-0-00	ZE05-2022SCF
Retainer Release Tool (Single-row products only : 2, 4, 5pos.)	ZE05-2DC-HU/R/RE-MD	CL0902-5144-0-00	-
Retainer Release Tool (Double-row products only : 8, 12, 16pos.)	ZE05-12DC-HU/R/RE-MD	CL0902-5143-0-00	-
Retainer Release Tool (Double-row products only : 20, 24pos.)	ZE05-20-24DC-HU/R/RE-MD	CL0902-5160-0-00	-
Terminal Extraction Tool	ZE05/RE-MD	CL0902-5145-0-00	-

Note 1 : Contact Japan Automatic Machine (J.A.M.) regarding crimping failure relating to applicable J.A.M. applicators or for other applicator inquiries via the J.A.M. website. (URL : <http://www.jam-net.co.jp>)

Note 2 : Hand tools are developed as a prototype tool during product development. Use an applicator for mass production.

Note 3 : Applicable cables are limited to 0.3 and 0.5sq. Cut the reel terminal for use with the hand tool.

Note 4 : Crimping should be carried out based on the "Crimping Quality Standards" and "Crimping Conditions Table."

Note 5 : Problems caused by tools other than those specified are not covered by the warranty.

## Usage Precautions

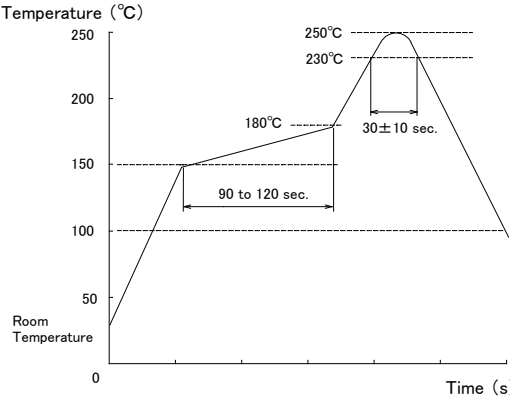
<p>Recommended Temperature Profile</p>	 <p><b>【Conditions】</b></p> <ol style="list-style-type: none"> <li>1. Reflow Heating Method Used : Far infrared, air atmosphere or nitrogen</li> <li>2. Peak Temperature 250°C Peak</li> <li>3. Heated part 230°C Min. 20-40 sec.</li> <li>4. Preheat Temperature 150 to 180°C 90-120 sec.</li> <li>5. Cycles 2 times Max.</li> </ol>
<p>Recommended Manual Soldering Conditions</p>	<p>Soldering iron temperature : 280 to 300°C , Soldering time : within 2 seconds</p>
<p>Cautions</p>	<ol style="list-style-type: none"> <li>1. Forcing the connector out might cause damage. If challenging to remove, gently press down once and then release the lock.</li> <li>2. Always disconnect the power before reseating the connector.</li> <li>3. Avoid touching the terminal area when the power is active, as it's hazardous.</li> <li>4. For harnessing guidelines, please consult a Hirose representative.</li> </ol>

## While Taking into Consideration

Specifications mentioned in this catalog are reference values.

When considering to order or use this product, please review the Drawing and Product Specifications sheets.

Use an appropriate cable when using the connector in combination with cables.

If considering usage of a non-specified cable, please contact your sales representative.

If assembly process is done by jigs & tools which are not identified by Hirose, the warranty of the product may be affected.

If considering usage for below mentioned applications, please contact your sales representative.

In cases where the application will demand a high level of reliability, such as automotive, medical instruments, public infrastructure, aerospace/defense etc. Hirose must review before assurance of reliability can be given.