

- Notes**
- Make sure that the O-ring is NOT twisting and properly assembled during this mounting process.
  - Use ring terminal M8 for the power contact. The recommended tightening torque of Ref. No. 10 and 11 is 6.0 to 6.5 N·m. Be sure to tighten Ref. No. 10 with the panel installed as shown in Fig-1. Do not tighten the bolt by itself during inspection. Recommended bolt size are as follows.
    - Ref. No. 10 : Screw size M8, Pitch 1.25 Length 10 to 12 mm. (For panel thickness, Refer to the next page Fig.1)
    - Ref. No. 11 : Screw size M8, Pitch 1.25 Length 12 to 15 mm. (Assume ring terminal thickness t = 2.5 to 3. When using ring terminal with different thickness, choose appropriate bolt size per the thickness.) To prevent loosening, use LOCTITE 243, HENKEL JAPAN or equivalent.
  - Mating connector at signal contact side is as follows.

Connector	GT8E-2S-2C	CL758-0030-6-00	
Crimp contact	GT8E-2022SCF(01)	CL758-0033-4-01	For AWG#20~22 Reel contact
	GT8E-2428SCF(01)	CL758-0055-7-01	For AWG#24~28 Reel contact

- Fig.1 shows the recommended panel cut out dimensions. Roughness on the panel surface indicated by for water sealing must be  $\sqrt{Rz} 3.2$
- This product is delivered with the plug and receptacle unmated as shown in Fig. 4.
- Appearance of each of the plug and receptacle are shown in Fig.2
- Lot No. is marked in one the indicated part shown.
- WARNING** Make sure the locking system firmly completed before using the this product. Fig.3 indicates rotated position of the plug and the receptacle with locking completed. Also, 'LOCK' marking on the receptacle can be seen from the plug hole.

- WARNING**
- Never engage/disengage the plug while the power contacts (Ref. No. 3 and Ref. No. 6) are energized. Signal contacts are sequentially connected after the power line in the plug engagement, and disconnected before the power line in the disengagement. Therefore, use the product with the circuit to avoid hot-plugging provided. Mating sequence of power line and signal line are shown in Fig. 1 along with the appearance and circuit of each state.
  - Rotated position of the plug and the receptacle are is shown as an exapmle.
  - For product handling, refer to the Operation guide ETAD-C0320.
  - Female contact Ref. No. 12 is loose before the bolt is attached to Ref. No. 11 and the female contact is movable as shown in Fig. 2, but stabilized to the receptacle after the screw fix. Therefore the looseness is eliminated for the use and does not affect its performance. (0.2) shown in Fig. 8 is the state when the bolt is tightened.
  - Engage the plug to the receptacle after all the assembly including cable wiring are completed for safety.
  - There are traces of white lubricant dry in the vicinity of that shown in the illustration D and E. It doe's not adversely affect the performance.

NO.	MATERIAL	FINISH	REMARKS	NO.	MATERIAL	FINISH	REMARKS
6	Hydrogenation acrylonitrile butadiene rubber	(Black)		12	Polybutylene terephthalate	(Black)	
5	Polybutylene terephthalate	(Orange)		11	Brass	Nickel plating	
4	Copper alloy	Gold plating 0.2μm MIN		10	Brass	Nickel plating	
3	Copper	Silver plating 3μm MIN		9	Hydrogenation acrylonitrile butadiene rubber	(Black)	
2	Hydrogenation acrylonitrile butadiene rubber	(Black)		8	Copper alloy	Silver plating 3μm MIN	
1	Polybutylene terephthalate	(Orange)		7	Copper alloy	Gold plating 0.2μm MIN	

UNITS	SCALE	COUNT	DESCRIPTION OF REVISIONS	DESIGNED	CHECKED	DATE
mm	1 : 2					
APPROVED : TP. KOMATSU			20220815	DRAWING NO. EDC-119542-06-00		
CHECKED : HY. KOBAYASHI			20220815	PART NO. EM30MSD-A(06)		
DESIGNED : TY. SUZUKI			20220812	CODE NO. CL0138-0206-0-06		
DRAWN : TY. SUZUKI			20220812	1/2		

Jun.1.2024 Copyright 2024 HIROSE ELECTRIC CO., LTD. All Rights Reserved.  
 In case of consideration for using Automotive equipment / device which demand high reliability, kindly contact our sales window correspondents.

4 Fig.1 The recommended panel dimention (t = 2 to 4.5)

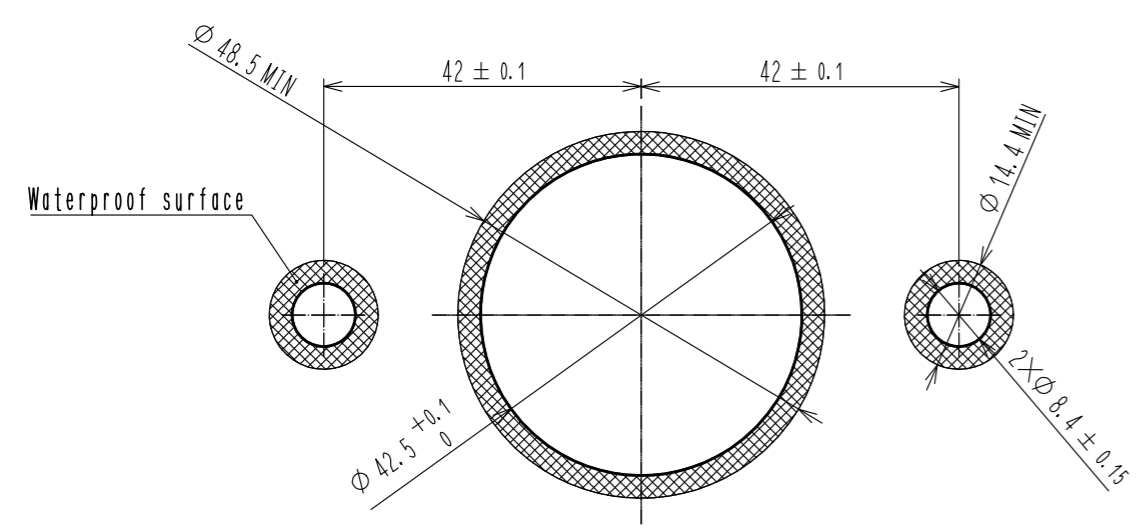

8 Fig.3 State of locked

\*LOCK\* indication is visible.  
 Top face of HRS logo becomes parallele to the shortsides of the receptacle.

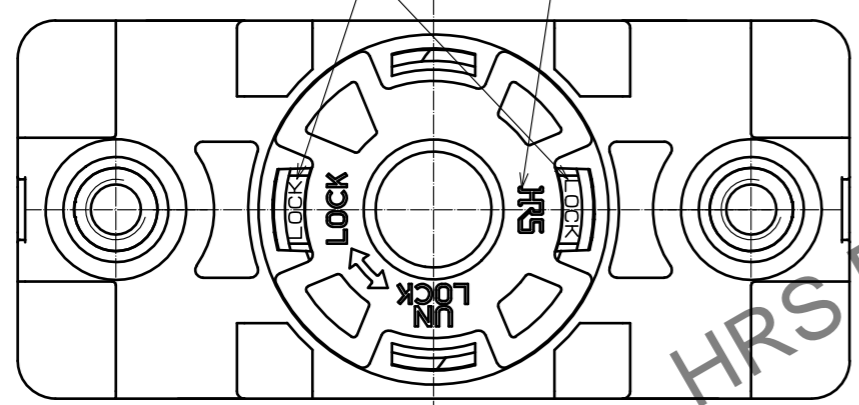

9 Table.1 Connection Timing (Power line and signal line)

Ⓐ-Ⓑ Power line  
 Ⓒ-Ⓓ Signal line

State	Before mating	Insertion plug	Rotated and Locked	Unlocked	Unmated
Appearance					
Connection		Power line closed. Signal line open. No power current.	Signal line closed. Power Line ON	Signal line open. Power Line OFF.	
Circuit diagram					

5 Fig.4 View of packing style

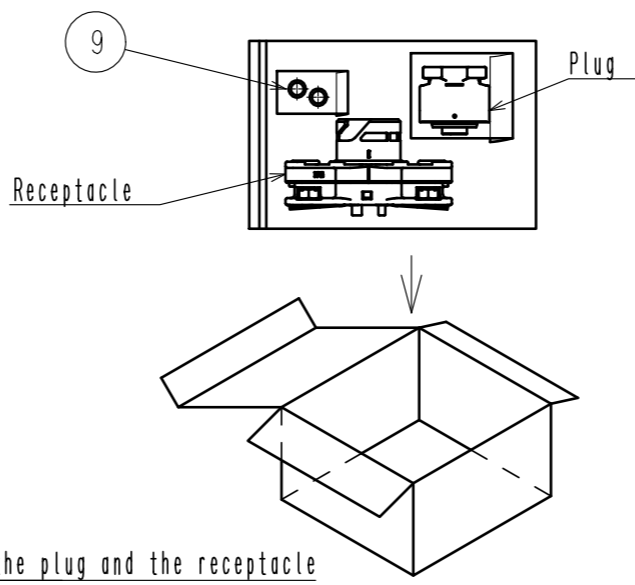

3 View of signal contact side

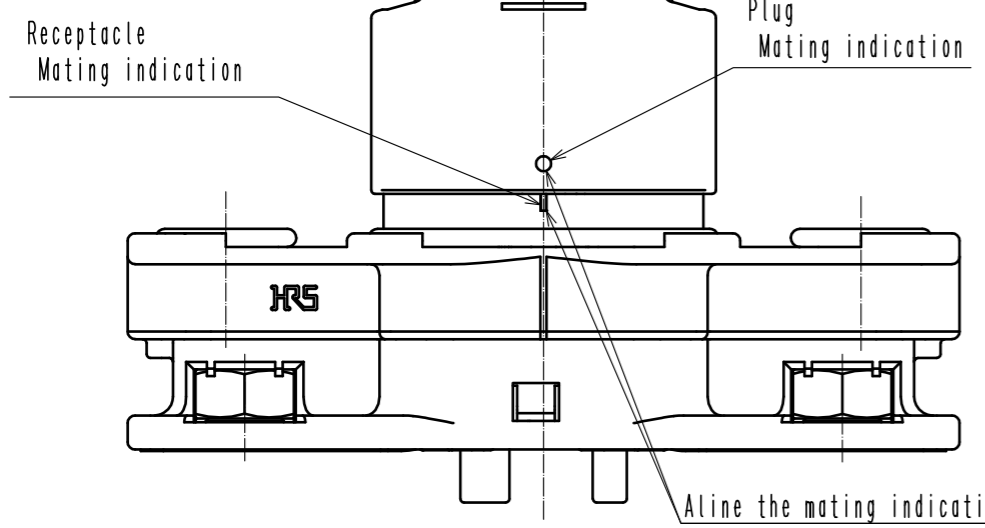
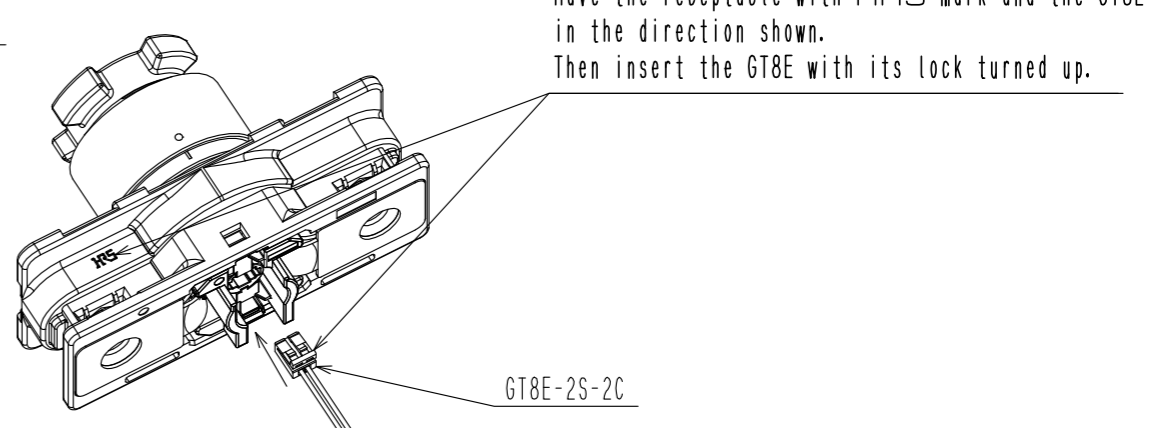

**HRS**

DRAWING NO.	EDC-119542-06-00
PART NO.	EM30MSD-A(06)
CODE NO.	CL0138-0206-0-06

2/2