

Feb.1.2025 Copyright 2025 HIROSE ELECTRIC CO., LTD. All Rights Reserved.
 In case of consideration for using Automotive equipment / device which demand high reliability, kindly contact our sales window correspondents.

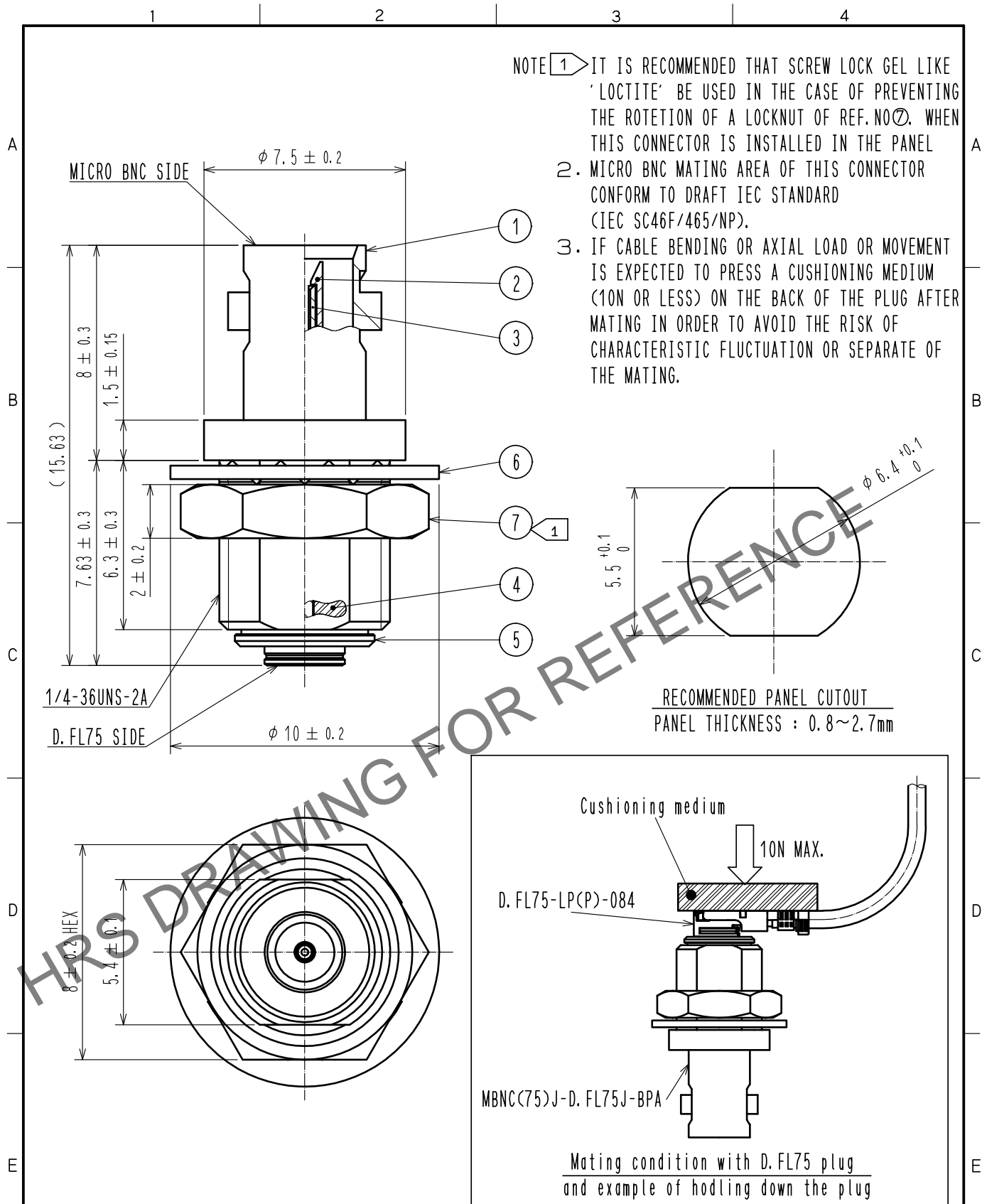

NOTE ① IT IS RECOMMENDED THAT SCREW LOCK GEL LIKE 'LOCTITE' BE USED IN THE CASE OF PREVENTING THE ROTATION OF A LOCKNUT OF REF. NO⑦. WHEN THIS CONNECTOR IS INSTALLED IN THE PANEL

2. MICRO BNC MATING AREA OF THIS CONNECTOR CONFORM TO DRAFT IEC STANDARD (IEC SC46F/465/NP).

3. IF CABLE BENDING OR AXIAL LOAD OR MOVEMENT IS EXPECTED TO PRESS A CUSHIONING MEDIUM (10N OR LESS) ON THE BACK OF THE PLUG AFTER MATING IN ORDER TO AVOID THE RISK OF CHARACTERISTIC FLUCTUATION OR SEPARATE OF THE MATING.

4	PTFE				
3	PHOSPHOR BRONZE	GOLD PLATING	7	BRASS	NICKEL PLATING
2	PTFE		6	PHOSPHOR BRONZE	NICKEL PLATING
1	BRASS	NICKEL PLATING	5	BRASS	NICKEL PLATING
NO.	MATERIAL	FINISH . REMARKS	NO.	MATERIAL	FINISH . REMARKS

UNITS mm		SCALE 5 : 1	COUNT 	DESCRIPTION OF REVISIONS	DESIGNED	CHECKED	DATE
HIROSE ELECTRIC CO., LTD.		APPROVED : NK. NINOMIYA 20220512	DRAWING NO.	EDC-393559-01-00			
		CHECKED : MT. KANEKO 20220512	PART NO.	MBNC(75)J-D. FL75J-BPA(01)			
		DESIGNED : YK. KIUCHI 20220512	CODE NO.	CL0311-0036-0-01			
		DRAWN : YK. KIUCHI 20220512		1/1			